

PERI UP Easy

Facade Scaffold 67 and 100 – Post variant

Instructions for Assembly and Use – Standard Configuration – Version 1.1

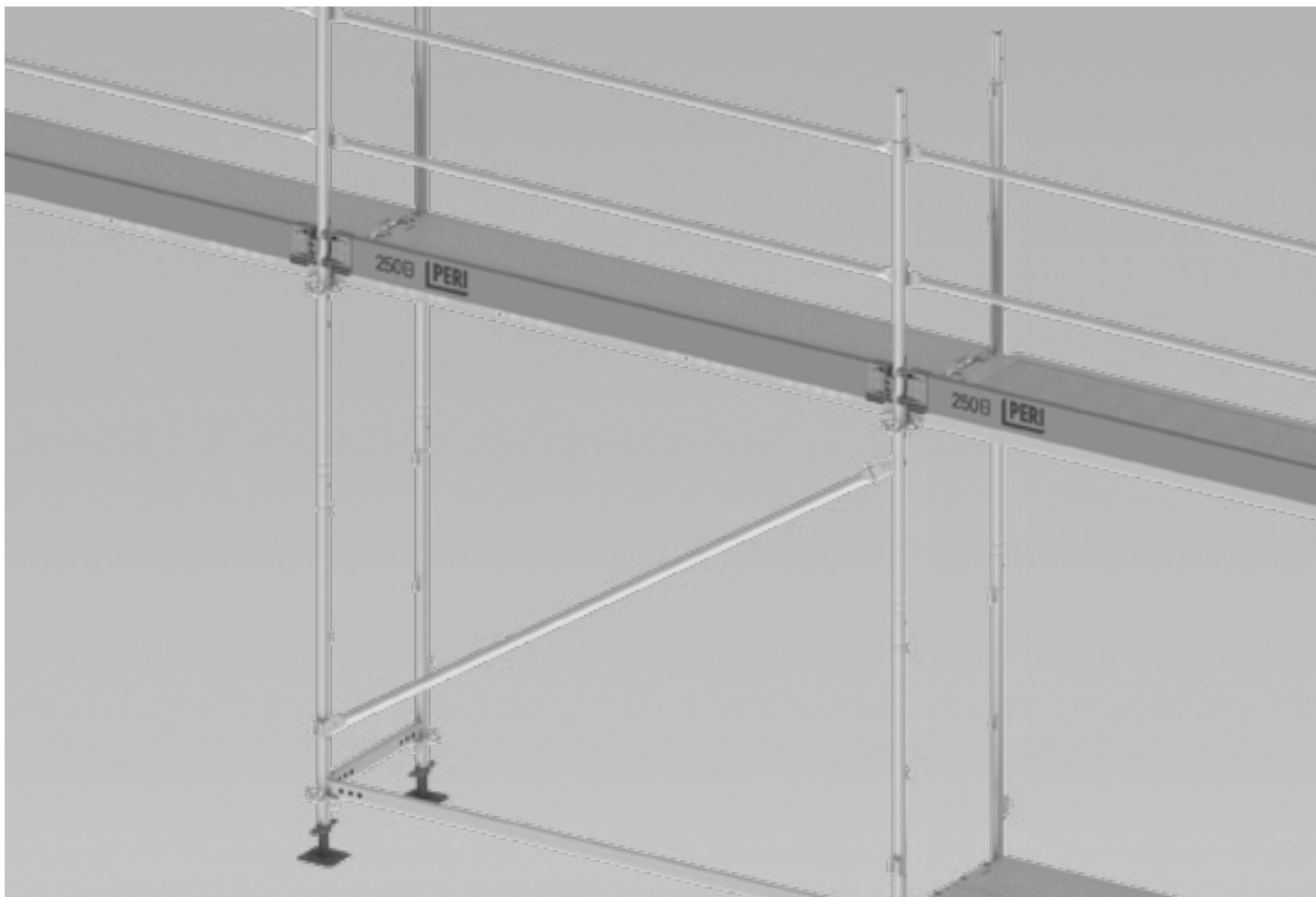

Overview			
Main components	4	A7 System component: Wall tie coupler	44
Key	5	Assembling the ties on the scaffold	44
Introduction		A8 Polycover – protection components	46
Target groups	6	General	46
Product description	7	Poly Cover Tube UPC-T	46
Cleaning and maintenance instructions	8	Poly Cover Rosette UPC-R	46
Disposal	8	Poly Cover Coupling UPC-C	47
Additional technical documentation	9	Spindle Lining UES	48
Instructions for Use	9	Basic scaffold	
Safety instructions		B1 Substructure	50
Cross-system	10	General	50
System-specific	12	Changes in height and inclined erection	
Anchoring	12	surfaces	50
Inspecting the anchoring	12	B2 First scaffold bay	54
Identification marking	13	General	54
Laws and regulations	13	Load-distributing supports	54
Inspection, handover and use	14	Base unit	55
Storage and transportation		Assembly aid for the decking	56
General	16	Easy standards and guardrail post	57
Safety during assembly		Decks	59
Vertical transportation	17	Face braces	59
Basic scaffolding in the standard		B3 Other scaffold bays	60
configuration	18	Lateral protection	61
Verified attachment points	19	B4 Other levels	64
System components		B5 Dismantling	66
A1 System configuration	20	B6 Corner configuration	68
Easy Standard variant	20	General	68
Easy frame variant	21	Outside corner	68
A2 Wedge connections	22	Inside corner	72
Stair Guardrails EAG	23	B7 Longitudinal infills	76
A3 System components: Lateral protection	24	General	76
Guardrail Post EPG	24	Assembly sequence	76
Advanced guardrail	25	Deck Compensation EDL 33	77
Wood toe board/steel toe board	26	Guardrail Posts	78
End Guardrail UPA in advance	29	Toe boards	78
End Guardrail EPF	31	Toe Board Compensation UPY-L	79
End Guardrail in Advance EPF	32	Cover Plate UDP	80
Replacing end guardrails	33	B8 Scaffold access	82
A4 System components: Deck	34	External access with staircase	82
Decks	34	Internal access with access deck	90
Internal access	36	B9 Scaffold modification	92
A5 System component: Diagonal Bracing	38	General	92
Face braces	38	Installing and removing scaffold bays	92
Internal braces	39	Closing scaffold areas	96
A6 System components: Console brackets	40	B10 Cladding	98
General	40	Nets/tarpaulin	98
Console brackets on the scaffold	41	Compatibility	
Console brackets with protection panel		C1 Compatibility	100
posts/guardrail posts	42	Compatible in 3 dimensions	100
Console brackets connected one behind		Side-by-side combination	101
the other	43	One above the other combination	102

Supplementary components

D1	Console brackets	104
	General	104
	Internal console brackets	104
	Internal console brackets with additional support	107
	Dismantling of internal console brackets	109
	Anchoring with ETICS	110
	External console brackets	111
	External corner with internal console brackets	114
	Console brackets at inside corners	115
D2	Protection panel	116
	General	116
	Protection panel on the base scaffold	116
	Protection panel on external console brackets	118
D3	Weather protection	124
	General	124
	Anchoring	124
	Assembly	125
	Tie pattern	128
	Keder tracks	129
D4	Protection roof	130
	General	130
	Protection roof on external console bracket	130
D5	Bridging	134
	General	134
	Bridging with auxiliary scaffolding	134
	Bracing and anchoring	138
	Bridging with 2 x 2 Formwork Girders ULS/ULA	140
D6	Pavement gantry	142
	General	142
	Assembling pavement gantries	145
	Scaffold assembly	148
D7	Scaffolding support	150
	Multi Brace EWB	150
	Bracing	154
	Push-Pull Prop RS	156

Static design of Easy 67 and 100

E1	Load-bearing capacities	158
	Decks	158
	Load-bearing capacity of the formwork girders	159
E2	Anchoring	160
	General	160
	Typical tie patterns	160
	Types of anchoring	163
E3	Tie pattern	166
	External scaffold access	166

Static design of Easy 67

F1	Tie forces	168
F2	Support forces	170
F3	Bridging	172
	Overview of requirements for formwork girders	172
F4	Tie pattern	173
	Overview of equipment variations	173
	Key	174
	Graphical tie pattern	176
F5	Uplifting wind forces	222

Static design of Easy 100

G1	Tie forces	224
G2	Support forces	225
G3	Formwork girders	228
	Overview of requirements for formwork girders	228
G4	Tie pattern	229
	Overview of equipment variations	229
	Key	230
	Graphical tie pattern	232
G5	Uplifting wind forces	236

Design variants

H	Examples	238
	General	238
	Scaffolding support	239
	Landing platform	240
	External access	241
	Adjusted roof protection	242
	Bridging with node braces	246

Program overview

	PERI UP Easy	248
--	--------------	-----

Main components

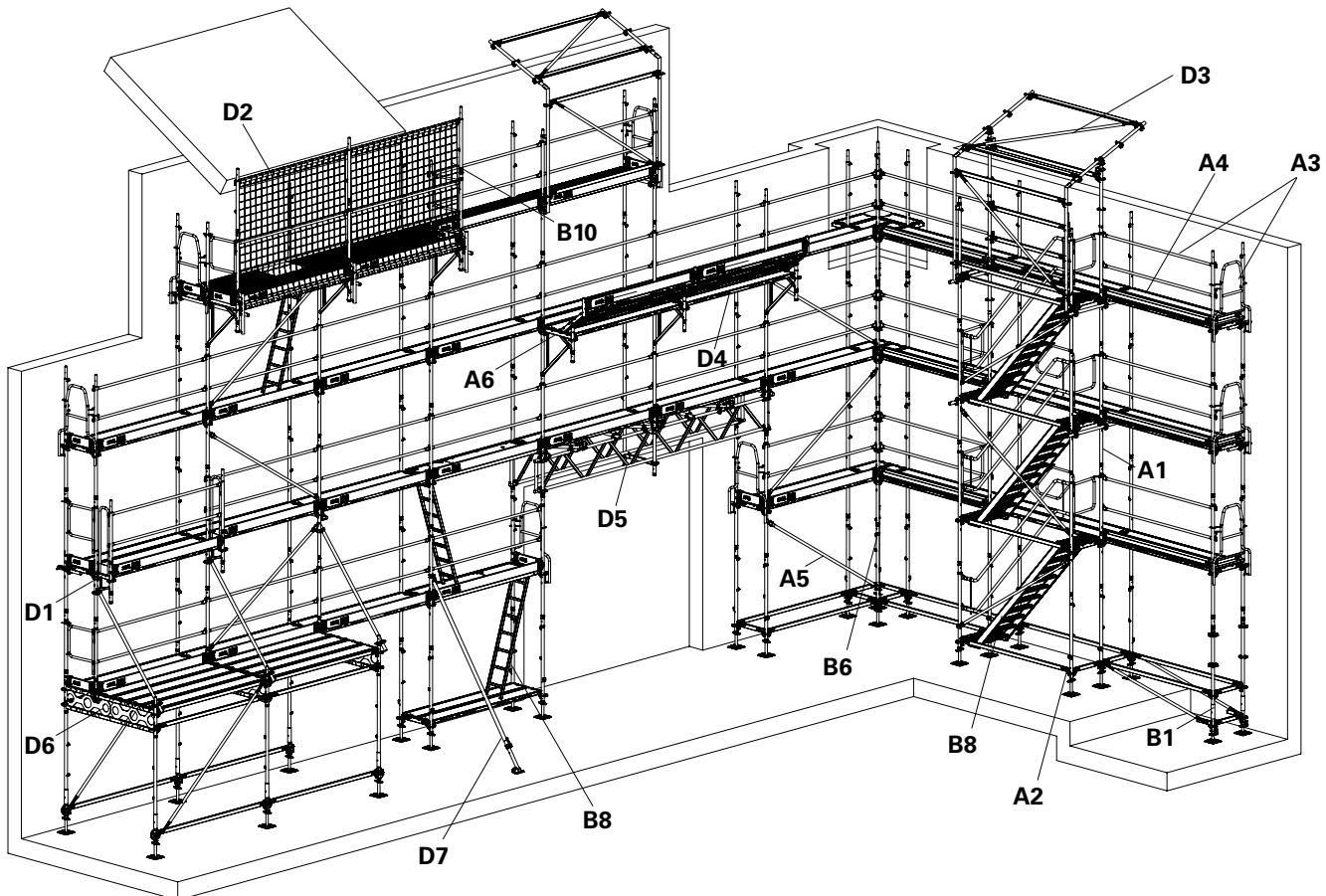

A1	System configuration	20	B1	Substructure	50
A2	Wedge connections	22	B2	First scaffold bay (not shown)	54
A3	Lateral protection	24	B3	Other scaffold bays (not shown)	60
A4	Decks	34	B4	Other levels (not shown)	64
A5	Braces	38	B5	Dismantling (not shown)	66
A6	Console brackets	40	B6	Corner configuration	68
A7	Wall tie coupler (not shown)	44	B7	Longitudinal infills (not shown)	76
A8	Polycover - protection components (not shown)	46	B8	Scaffold access	82
			B9	Scaffold modification (not shown)	92
			B10	Cladding	98
			D1	Console brackets	104
			D2	Protection panel	116
			D3	Weather protection roof	124
			D4	Protection roof	130
			D5	Bridging	134
			D6	Pavement gantry	142
			D7	Scaffolding support	150

Key

Pictogram | Definition



Danger/Warning/Caution



Note



To be complied with



Load-bearing point



Visual inspection



Tip



Incorrect use



Safety helmet



Safety shoes



Safety gloves



Safety goggles



Personal protective equipment to prevent falling from a height (PPE)

Arrows



Arrow representing an action



Arrow representing a reaction of an action*



Arrow representing forces

* If not identical to the action arrow.

Safety instruction categories

The safety instructions alert site personnel to the risks involved and provide information on how to avoid these risks. Safety instructions are featured at the beginning of the section or ahead of the instructions, and are highlighted as follows:



Danger

This sign indicates an extremely hazardous situation, in which case, not following the safety instructions will result in death or serious, irreversible injury.



Warning

This sign indicates a hazardous situation which, if not avoided, could result in death or serious, irreversible injury.



Caution

This sign indicates a hazardous situation, in which case, not following the safety instructions could result in minor or moderate injury.



Note

This sign indicates situations in which failure to observe the information can result in material damage.

Format of the safety instructions



Signal word

Type and source of hazard!
Consequences of non-compliance.
⇒ Preventative measures.

Dimensions

Dimensions are usually given in cm. Other measurement units, e.g. m, are shown in the illustrations.

Conventions

- Instructions are numbered with:
1., 2., 3.
- The result of an instruction is shown by: →
- Position numbers are clearly provided for the individual components and are given in the drawing, e.g. **1**, in the text in brackets, for example **(1)**.
- Multiple position numbers, i.e. alternative components, are represented with a slash: e.g. **1/2**.

Notes on illustrations

The illustration on the front cover of these instructions is understood to be a system representation only. The assembly steps presented in these Instructions for Assembly and Use are shown in the form of examples with only one component size. They are valid for all component sizes contained in the standard configuration.

To facilitate understanding, illustrations are sometimes incomplete. Any safety equipments that are not shown in these illustrations must be incorporated nonetheless.

Terminology

Components are not always named in full so that they are easier to read. All components deemed valid according to the program overview may be used. Exceptions are specified.

Example:

- Horizontal ledger corresponds to:
- Horizontal Ledger UH Plus
- Horizontal Ledger UH-2.

Target groups

Scaffolding contractors/contractors

These assembly instructions are intended for contractors who either

- assemble, modify and dismantle the scaffolding, or
- use them, e.g. for concreting, or
- allow them to be used for other operations, e.g. carpentry or electrical work.

Safety and Health Protection Coordinator*

- is appointed by the client,
- must identify potential hazards during the planning phase,
- determines measures that provide protection against risks,
- creates a safety and health protection plan,
- coordinates the protective measures for the contractor and site personnel so that they do not endanger each other,
- monitors compliance with the protective measures.

Competent person

- is appointed by the scaffolding contractor,
- must be on site for all scaffolding work,
- prepares and updates the plan for assembly, modification and dismantling,
- prepares and updates the plan for use of the scaffold by the scaffold user,
- supervises the assembly, modification and dismantling work (supervisor).

Competent persons qualified to carry out inspections

Due to the specialist knowledge gained from professional training, work experience and recent professional activity, the competent person qualified to carry out inspections has a reliable understanding of safety-related issues and can carry out inspections correctly. Depending on the complexity of the inspection to be undertaken, e.g. scope of testing, type of testing or the use of certain measuring devices, a range of specialist knowledge is necessary.

Qualified personnel

Scaffolds may only be assembled, modified or dismantled by personnel who are suitably qualified to do so. Qualified personnel must have completed a course of training** in the work to be performed, covering the following points at least:

- Explanation of the plan for the assembly, modification or dismantling of the scaffolding in an understandable form and language.
- Description of the measures for safely assembling, modifying or dismantling the scaffold.
- Naming of the preventive measures to be taken to avoid the risk of persons and objects falling.

- Designation of the safety precautions in the event of changing weather conditions that could adversely affect the safety of the scaffolding, as well as the personnel concerned.
- Details regarding permissible loads.
- Description of all other risks and dangers associated with assembly, modification or dismantling operations.



- **In other countries, ensure that the relevant national guidelines and regulations in the respective current version are complied with!**
- **If no country-specific regulations are available, it is recommended to proceed according to German guidelines and regulations.**

* Valid in Germany: Regulations for Occupational Health and Safety on Construction Sites 30 (RAB 30).

** Instructions are given by the contractor themselves or a competent person selected by them.

Product description

Purpose of these assembly instructions

These Instructions for Assembly and Use are based on Approval Z-8.1-957 and Z-8.1-970 for the PERI UP Easy scaffold system.

They describe the standard configuration for a facade scaffold as a working and safety scaffold according to the provisions set down in DIN 4420-1 as well as the requirements as a scaffold system according to EN 12810 and EN 12811.

These Instructions for Assembly and Use show the assembly with

- a scaffold width of 67 cm,
- with Steel Decks EDS,
- with Toe Board UPF.

The assembly process with

- a scaffold width of 100 cm,
- other decks,
- Toe Board UPY

is carried out in the same way.

Intended use

PERI products have been designed for exclusive use in the industrial and commercial sectors only by suitably trained personnel.

Features

The PERI UP Easy scaffold system is a length-oriented steel scaffold in frame and standard versions comprised of prefabricated components with supplementary components. In these Instructions for Assembly and Use, only the standard variant is considered. For the frame variant, see the Instructions for Assembly and Use for the PERI UP Easy Facade Scaffolding 67 and 100, frame variant.

For use as working scaffold in:

Easy 67:

Load Class 1 – 3 according to EN 12811-1

0.75 – 2.00 kN/m².

Easy 100:

Load Class 1 – 4 according to EN 12811-1

0.75 – 3.00 kN/m².

Fulfils the requirements for safety scaffolds (edge and roof edge protection scaffolds for falling heights ≤ 2.0 m, protection roofs) according to DIN 4420-1.

The standard configuration covers a scaffold assembly with a height of 24 m plus the maximum spindle extension.

The standard configuration for clad scaffolds applies to cladding with netting having aerodynamic force coefficients not in excess of $c_{f\perp} = 0.6$ and $c_{f\parallel} = 0.2$, and to cladding with tarpaulins. In the case of clad scaffolds, these must always be closed up to the erection surface and around the front sides of the scaffold, i.e. the tarpaulin or netting must be stretched all the way to the facade. Wind load is calculated with an exposure-time factor of $\alpha = 0.7$, which assumes a maximum exposure time of 2 years.

Technical data

System width: 67 cm or 100 cm

Decking width: 66 cm or 100 cm

Scaffold bay lengths:

67/100/150/200/250/300 cm

Product description according to EN 12810:

PERI UP Easy 67 EN 12810-3D-SW06/300-H2-B-LS

PERI UP Easy 100 EN 12810-4D-SW09/300-H2-A-LS

Explanation:

3 = Load Class 3 (LC 3= 2.00 kN/m²)

4 = Load Class 4 (LC 4 = 3.00 kN/m²)

D = decking with drop test suitable as safety scaffold

SW06 = Width Class 06

(0.6 \leq w < 0.9 m)

SW09 = Width class 09

(0.9 \leq w < 1.2 m)

300 = bay length ≤ 300 cm

H1/H2 = height class depending on the anchoring used.

A = without cladding

B = with cladding

LS = equipment with ladder and stairs

Cleaning and maintenance instructions

Clean the scaffold components after each use to maintain the value and operational readiness of the PERI products over the long term.

Some repair work may also be inevitable due to the tough working conditions.



The contractor must ensure that the personal protective equipment required for cleaning, maintenance and repair work, e.g.

- safety helmet,
- safety shoes,
- safety gloves,
- safety goggles,

is available and used as intended.

The following points should help to keep cleaning and maintenance costs as low as possible.

Cleaning tools must be adapted to the respective surfaces of the components so that they are not damaged.

Mechanical components, e.g. spindles, must be cleaned of dirt or concrete residue before and after use, and then greased with a suitable lubricant.

Do not use plastic components if fibre reinforcements are exposed.

Provide suitable support for the components during cleaning so that no unintentional change in their position is possible.

Do not clean components suspended on crane lifting gear.

Components with wood parts are to be stored in well-ventilated and dry conditions.

Any repairs to PERI products are to be carried out by PERI qualified personnel only.

Disposal

Dispose of in accordance with the relevant national regulations.

Additional technical documentation

Approvals:

- Z-8.1 – 970 PERI UP Easy 100
- Z-8.1 – 957 PERI UP Easy 67

Instructions for Assembly and Use:

- PERI UP Easy Facade Scaffold 67 and 100, Frame Variant
- PERI UP Flex Stair Aluminium 75
- PERI UP Flex Stair 100 and 125 with Deck UDG
- PERI UP Scaffolding Kit – Core components

Instructions for Use

Use in a way not intended, deviating from the standard configuration or the intended use according to the Instructions for Assembly and Use, represents an application with a potential safety risk, e.g. risk of falling.

Deviations from the standard configuration must be verified for the application by means of separate strength and stability calculations (Industrial Safety Regulation Appendix 1, No. 3.2.1) and explicitly reflected in the assembly instructions.

All components listed in the program overview may be used for assembly. Other components are not permitted. Exceptions are named, or must be planned and verified on a project-specific basis.

The use of other products and spare parts is not allowed. Changes to PERI components are not permitted.

The system described in these Instructions for Assembly and Use may contain patent-protected components.

Cross-system



Safety instructions apply to all service life phases of the system.

General

The contractor must ensure that the Instructions for Assembly and Use supplied by PERI are available at all times and understood by the site personnel.

These Instructions for Assembly and Use can be used as the basis for creating a risk assessment. The risk assessment is compiled by the contractor. However, these Instructions for Assembly and Use do not replace the risk assessment!

Refer to and comply with the safety instructions and permissible loads.

For the application and inspection of PERI products, the current safety regulations and guidelines valid in the respective countries must be observed.

Materials and working areas are to be inspected before each use and assembly, for:

- damage,
- stability and
- functional correctness.

Damaged components must be exchanged immediately on site and may no longer be used.

Safety components are to be removed only when they are no longer required.

When on slab formwork, scaffolds and working platforms:

- do not jump,
- do not run,
- do not drop anything from or onto it.

Components provided by the contractor must comply with the characteristics stipulated in these Instructions for Assembly and Use and all applicable laws and standards. Unless otherwise indicated, the following applies in particular:

- timber components: strength class C24 for solid wood according to EN 338.
- Scaffold tubes: galvanised steel tubing with minimum dimensions $\varnothing 48.3 \times 3.2$ mm according to EN 12811-1 2004-3 4.2.1.2.
- scaffold tube couplings according to EN 74-1 and EN 74-2.

Deviations from the standard configuration are only permitted after a further risk assessment has been carried out by the contractor.

Appropriate measures for working and operational safety, as well as stability, are defined on the basis of this risk assessment.

Corresponding proof of stability can be provided by PERI on request, if the risk assessment and resulting measures to be implemented are made available.

Before and after exceptional occurrences that may have an adverse effect on the safety of the scaffold system, the contractor must immediately

- produce another risk assessment and make use of its results to take suitable steps to guarantee the stability of the scaffold system,
- arrange for an extraordinary inspection to be carried out by a competent person qualified to do so. The aim of this inspection is to identify and rectify any damage in good time in order to guarantee safe use of the scaffold system.

Exceptional events could be:

- accidents,
- long periods of non-use,
- natural events, e.g. heavy rainfall, icing, heavy snowfall, storms or earthquakes.

Assembly, modification and dismantling work

Assembly, modification or dismantling of scaffold systems may only be carried out by qualified persons under the supervision of a competent person. The qualified personnel must have received appropriate training for the work to be carried out with regard to specific risks and dangers.

On the basis of the risk assessment and the Instructions for Assembly and Use, the contractor must create installation instructions to guarantee safe assembly, modification and dismantling of the scaffold system.

Before initial use, the safe functioning of the scaffold must be checked by a person qualified to carry out the inspection. The results of the inspection must be documented in an inspection log.



The contractor must ensure that the personal protective equipment required for the assembly, modification or dismantling of the scaffold system, e.g.

- safety helmet,
- safety shoes,
- safety gloves,
- safety goggles,

is available and used as intended.

The scaffolding is disassembled by reversing the assembly sequence as described in these Instructions for Assembly and Use.

Comply with the respective assembly descriptions and safety instructions when making modifications or additions to the scaffolding.



If personal protective equipment against falling from a height (PPE) is required or specified in local regulations, the contractor must determine appropriate attachment points on the basis of the risk assessment.

For verified attachment points, see Section "Verified attachment points" on page 19.

The PPE against falling to be used is determined by the contractor.

The contractor must

- provide safe working areas for site personnel, which are to be reached through the provision of safe access ways. Danger zones must be cordoned off and clearly marked.
- guarantee stability during all stages of construction, in particular during assembly, modification and dismantling operations.
- ensure and demonstrate that all loads that occur are safely transferred.

Use

Every contractor who uses or allows the scaffold systems to be used, is responsible for ensuring that the equipment is in good condition.

If the scaffold system is used successively or at the same time by several contractors, the health and safety coordinator must point out any possible mutual hazards and all work must then be coordinated.

When scaffolds are used in publicly accessible areas,

- measures to prevent unauthorised use, e.g. enclosure of access areas, must be taken.
- Measures are taken against injuries caused by bumping against protruding components, e.g. assembly of protective components.

Always keep the contact surfaces of the scaffolding free of dirt, objects, snow and ice.

Close off the scaffold in extreme weather conditions.

System-specific

The load-distributing support used, such as planking, must match the respective substrate. If multiple layers are required, planks are to be arranged crosswise.

It must be ensured that the scaffolding cannot shift in a horizontal direction, irrespective of what substrate is being used.

Access hatches close automatically. Do not disable the mechanism.

Couplings with screw closures must be tightened with 50 Nm. This corresponds to a force of 20 kg using a lever arm length of 25 cm.

Secure the wedges with a jarring blow using a 500 g hammer.

Anchoring

Refer to the Section "Static design" for the anchoring forces and the anchoring positions.

Enclosing the scaffold, or mounting additional surfaces that are exposed to the influences of the wind, changes the stability. As a result, the stability must be re-assessed.

If necessary, additional measures must be implemented.

Anchoring must be installed progressively with the erection of the scaffold assembly.

The anchoring forces must be transferred into sufficiently load-bearing anchorage via wall ties and fixing materials e.g. the building.

Inspecting the anchoring

The anchoring and its components must be inspected by a qualified person nominated by the scaffolding contractor.

Load tests must be carried out at the place of use.

Load tests are to be carried out using suitable test equipment.

The test load must be 1.2 times higher than the required anchoring force F_{\perp} .

The scope of testing must, however, include a minimum of 5 load tests for all dowels used for concrete anchoring bases (at least 10%) and for other building materials (at least 30%).



Ensure that the relevant national guidelines and regulations are complied with!

Identification marking

When carrying out the work the following signs must be observed:

If certain parts of the scaffold are not ready for use – especially during assembly, modification and dismantling – a “No Entry” warning sign restricting access must be clearly displayed (see Sign 1).

In addition, the area must be adequately closed off in order to prevent access.



Sign 1

Montageprotokoll	
auszufüllen vom Aufsichtführenden	
Aufstellort	_____
Position	_____
Auftraggeber	_____
Gerüstersteller	_____
Datum	_____
Unterschrift	_____
Arbeitsgerüst nach EN 12811, für Lastklasse	
<input type="checkbox"/>	kN/m ² <small>1-2: Wartungsarb. 1,50 kN/m² 3: Maler- Putzerb. 2,00 kN/m² 4-6: Mauerarb. > 2,00 kN/m²</small>
Breitenklasse W	
<input type="checkbox"/>	W06 0,6 ≤ w ≤ 0,9 m
<input type="checkbox"/>	W09 0,9 ≤ w ≤ 1,2 m
<input type="checkbox"/>	W12-W24 w ≥ 1,2 m
Abnahmeprotokoll	
auszufüllen vom Prüfer	
Name	_____
Unterschrift	_____
Datum, Uhrzeit	_____
Besonderheiten	_____

© 2007 PERI GmbH. All Rights Reserved 113833	

Sign 2

After assembly has been completed, all scaffold entry points must clearly display the designated sign.

(Sign 2)

The identification marking do not replace the inspection log! (Sign 2, rear side)

Prüfprotokoll		
Prüfung durch befähigte Person		
Achtung Veränderungen am Gerüst, z.B. Entfernen der Verankerungen, dürfen nur vom Gerüstersteller durchgeführt werden.		
Datum	Uhrzeit	Unterschrift
Gerüst stillgelegt:		
Datum:		

Sign 2, rear side

Laws and regulations

When assembling, modifying, dismantling and using the scaffolding in Germany, accident prevention regulations and guidelines of the employer’s liability insurance associations, as well as national health and safety regulations, must be followed, especially:

- German Product Safety Act (ProdSG)
 - Directive 2009/104/EC
 - Occupational Health and Safety Act (ArbSchG)
 - Operating Safety Regulation (BetrSichV)
 - Statutory Accident Insurance (DGUV) Information 201-011
 - BGV A1 (Trade Association Regulations)
 - TRBS 2121 (Technical Regulations for Operational Safety)
 - TRBS 1203 (Technical Regulations for Operational Safety)
 - Regulations for Occupational Health and Safety on Construction Sites 30 (RAB 30)
- The latest version in each case is applicable.



In other countries, ensure that the relevant national guidelines and regulations in the respective current version are complied with!

Inspection, handover and use

The erected scaffold must be inspected by the scaffolding contractor in order to determine that assembly has been carried out correctly. If the contractor is convinced that the scaffold has been correctly erected, it can then be handed over to the user.

It is advisable to carry out the handover with the user and, for example, to document this in a written report.



During the handover, the scaffolding contractor must advise the user of any possible risks involved with non-intended use and his obligation to provide adequate prevention against risk and danger!

- Put up safety and warning signs at the scaffold access point.
- Handover of a usage plan.



The contractor who uses the scaffolds, must ensure that the scaffolding is in good condition and not arbitrarily altered in any way. In this respect, the qualified specialists must be instructed that if changes have obviously been made during use, these must be reported to the respective qualified and competent person.

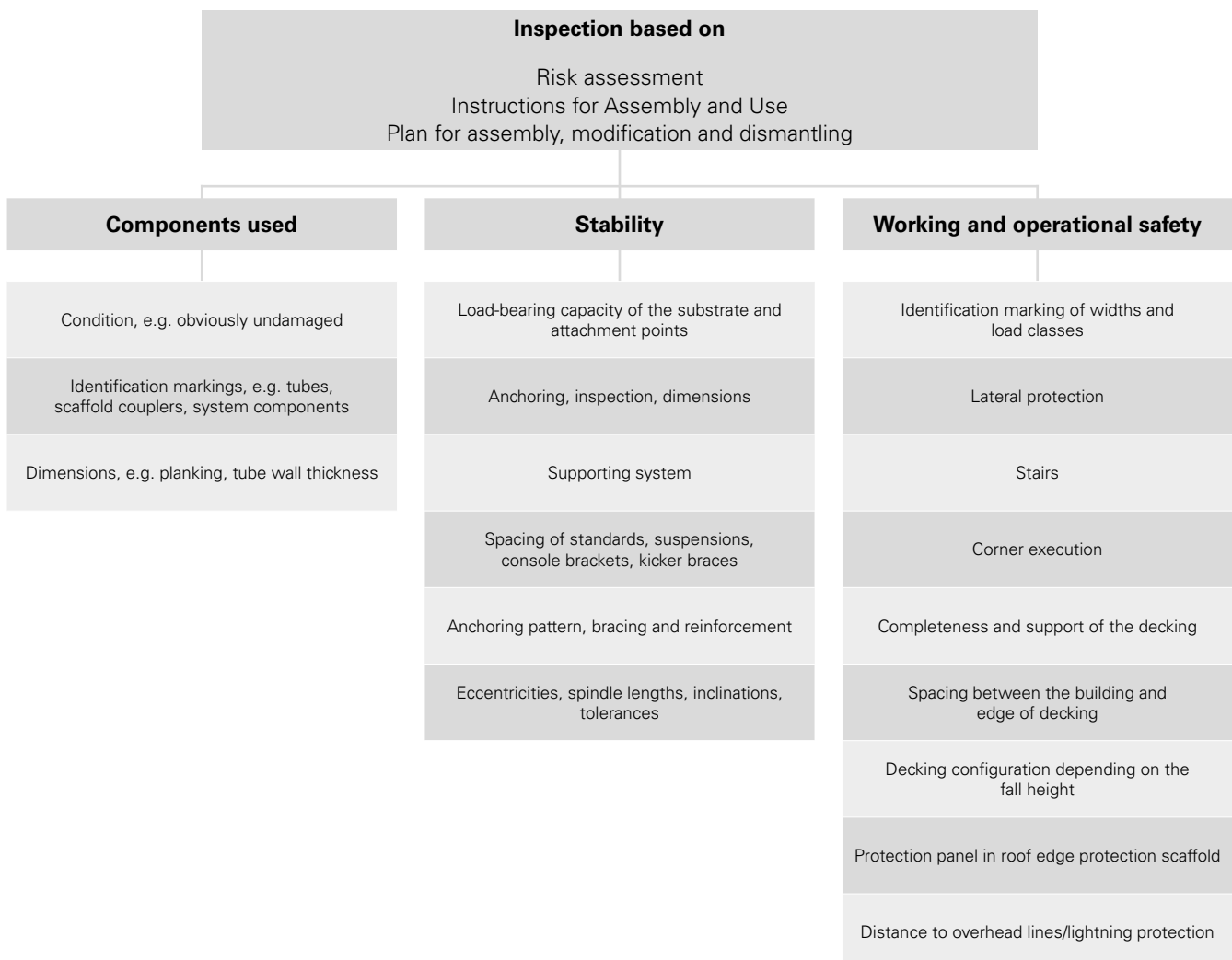

Source: based on TRBS 2121 Part 1

General

- Store and transport components in such a way that no unintentional change in their position is possible. Detach lifting accessories and slings from the lowered components only if they are in a stable position and no unintentional change is possible.
- Do not drop the components.
- Only ever use approved and inspected means of transportation from PERI incl. lashing, lifting gear and slings.
- Only attach the means of transport to the intended attachment points using suitable lifting gear and slings.

During the relocation procedure

- ensure that components are picked up and set down so that unintentional falling over, falling apart, sliding, falling down or rolling is avoided.
- no persons are allowed to remain under the suspended load.
- The access areas on the construction site must be free of obstacles and tripping hazards, as well as being slip-resistant.
- For transportation, the substrate must have sufficient load-bearing capacity.
- Use original PERI storage and transport systems, e.g. crate pallets, pallets or stacking devices.

Vertical transportation



Note

Adverse effect on safety levels due to damaged scaffold components!

- ⇒ Do not drop scaffold components!
- ⇒ Transport and store scaffold components in a way that poses no risk of damage to the components.

- For assembly, modification and disassembly work, guardrails and intermediate guardrails must be installed at all times in the material acceptance bay. If double-advanced guardrail posts are used, every bay is a material acceptance bay.
- Vertical transportation must be carried out under the supervision of site personnel in all situations.

If scaffolds higher than 8 m (deck height above erection surface) are being erected, construction hoists or winches should be used for vertical transportation of the scaffolding components.

Observe the respective manufacturer's documentation!

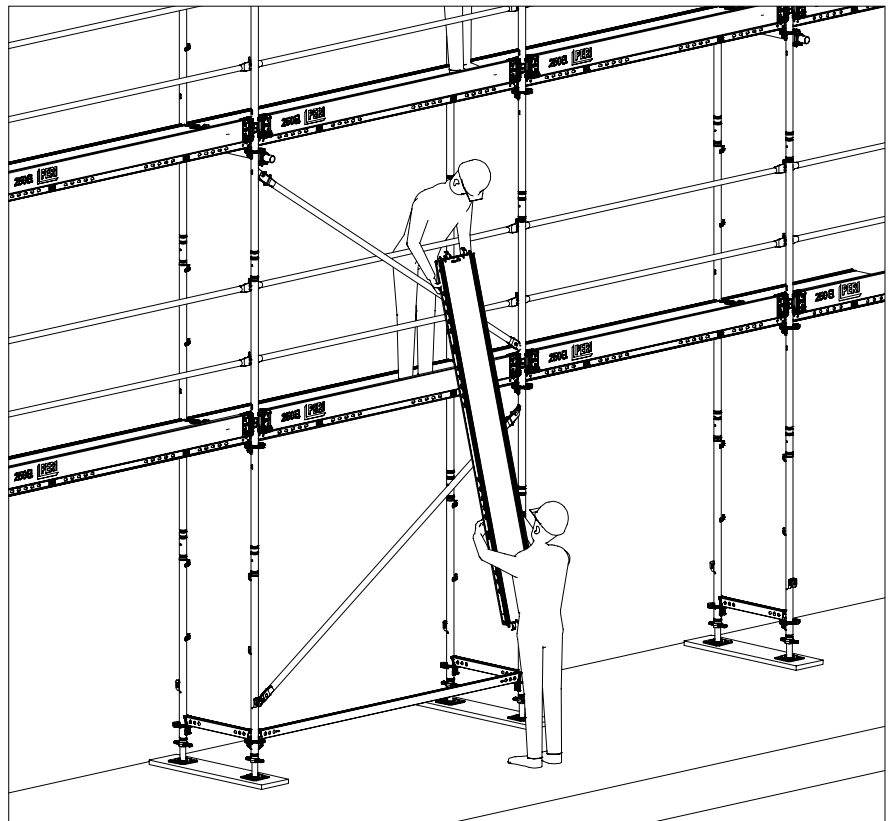

Fig. E.01

Basic scaffolding in the standard configuration

Working situation:
Assembly/dismantling of all scaffold components. (Easy standards, horizontal ledgers, lateral and end protection, decks, ties)

Assembly with guardrail in advance as system-integrated guardrails

From the most recently completed scaffold level, the top guardrail for the next scaffold level is assembled together with the Easy Standard.

The end guardrail for the next scaffold level is also installed from the level below.

The scaffold constructors will come across the end guardrail and upper guardrail posts straight away, allowing them to continue with installation from a safe working position. (Fig. E.02)



Comply with the prescribed assembly sequences!

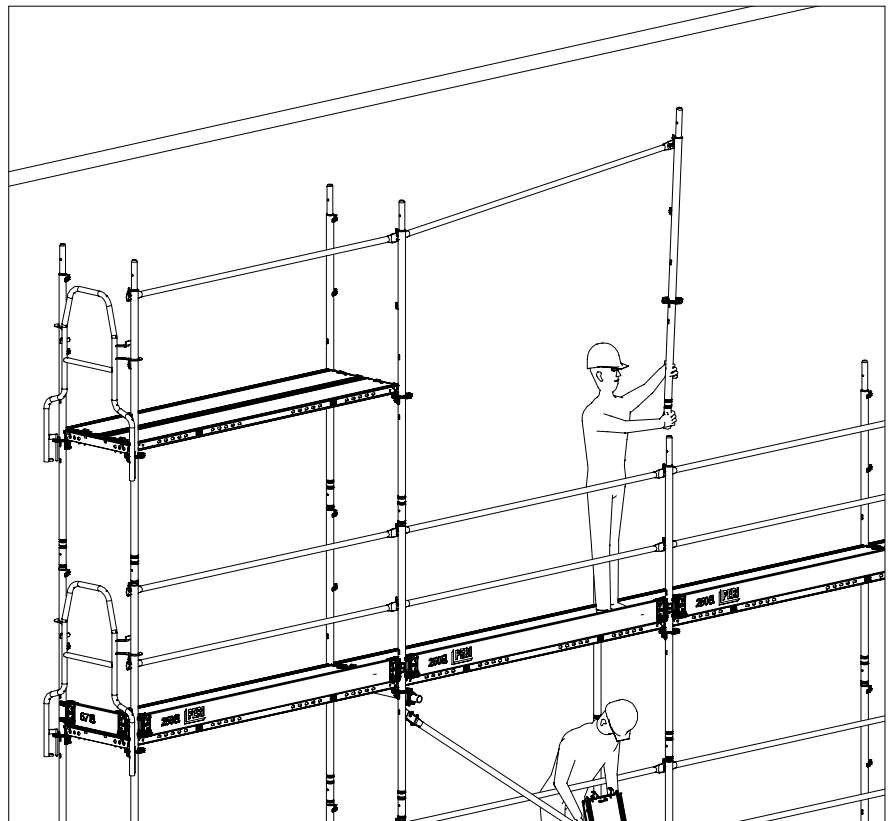

Fig. E.02



Assembly of the Easy Standard can also be carried out in a "double-advanced" manner with guardrails and intermediate guardrails. (Fig. E.03)

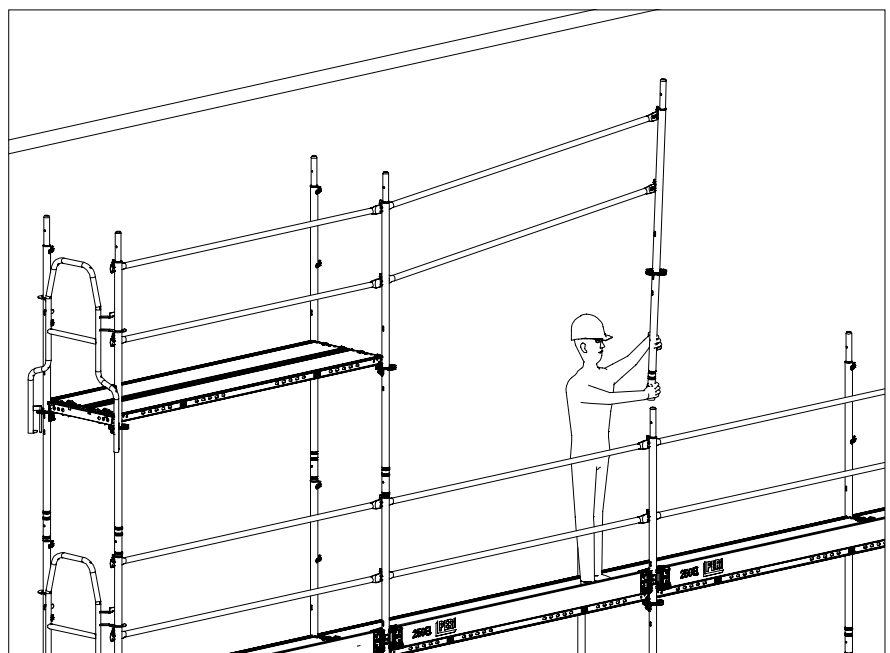

Fig. E.03

Verified attachment points

Certain assembly situations could occur that require the use of personal protective equipment (PPE) to prevent falling from a height. For this, the following verified attachment points must be used:

All attachment points require the following:

- The standing height can be a maximum of one level above the last anchoring position.
- At least one anchoring position must be available at all times.
- The attachment points shown apply to frame and standard variants.

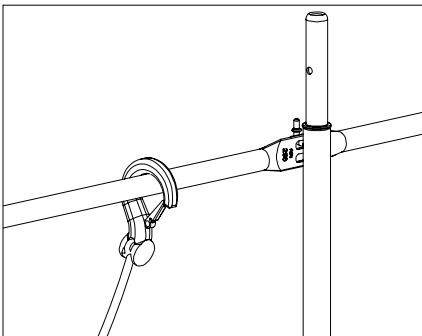

Fig. E.04

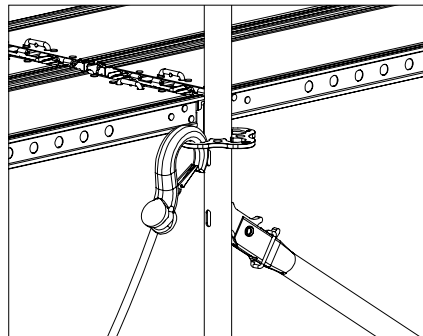

Fig. E.05

Guardrail post

Attachment point:

Each Guardrail Post EPG or intermediate guardrail,

- which is connected to two Easy Standards EVM
- whereby both the guardrail and intermediate guardrail are installed
- and is mounted a maximum 1.0 m above the decking level.

Rosette

Attachment point:

Each rosette on Easy Standard EVM and Top Standard EVT,

- which are integrated in the basic scaffold
- and which are completely covered with decking.



Guardrail Posts which are connected to Tubes EVP, EVR or EVS are not attachment points.

Easy Standard variant

This variant is described in these Instructions for Assembly and Use. The scaffold side that faces the building is always referred to as the inner side of the scaffolding.

Horizontal Ledger UH-2 67/100
as a crossbar.

Top Standard EVT 96

Height = 0.96 m.
The standards can be used on both the inner and outer sides.

Easy Standard EVM 200

Height = 2.00 m.
The standards can be used on both the inner and outer sides.

Easy Base Standard EVS 124

Height = 1.24 m.
The standards can be used on both the inner and outer sides.
The guardrail pins should be pointing towards the decking side.

Base Spindles UJB
see the following page.

Optional

Base Compensation EVA

available in 0.50 m and 1.00 m compensation heights. (Fig. A1.01a)

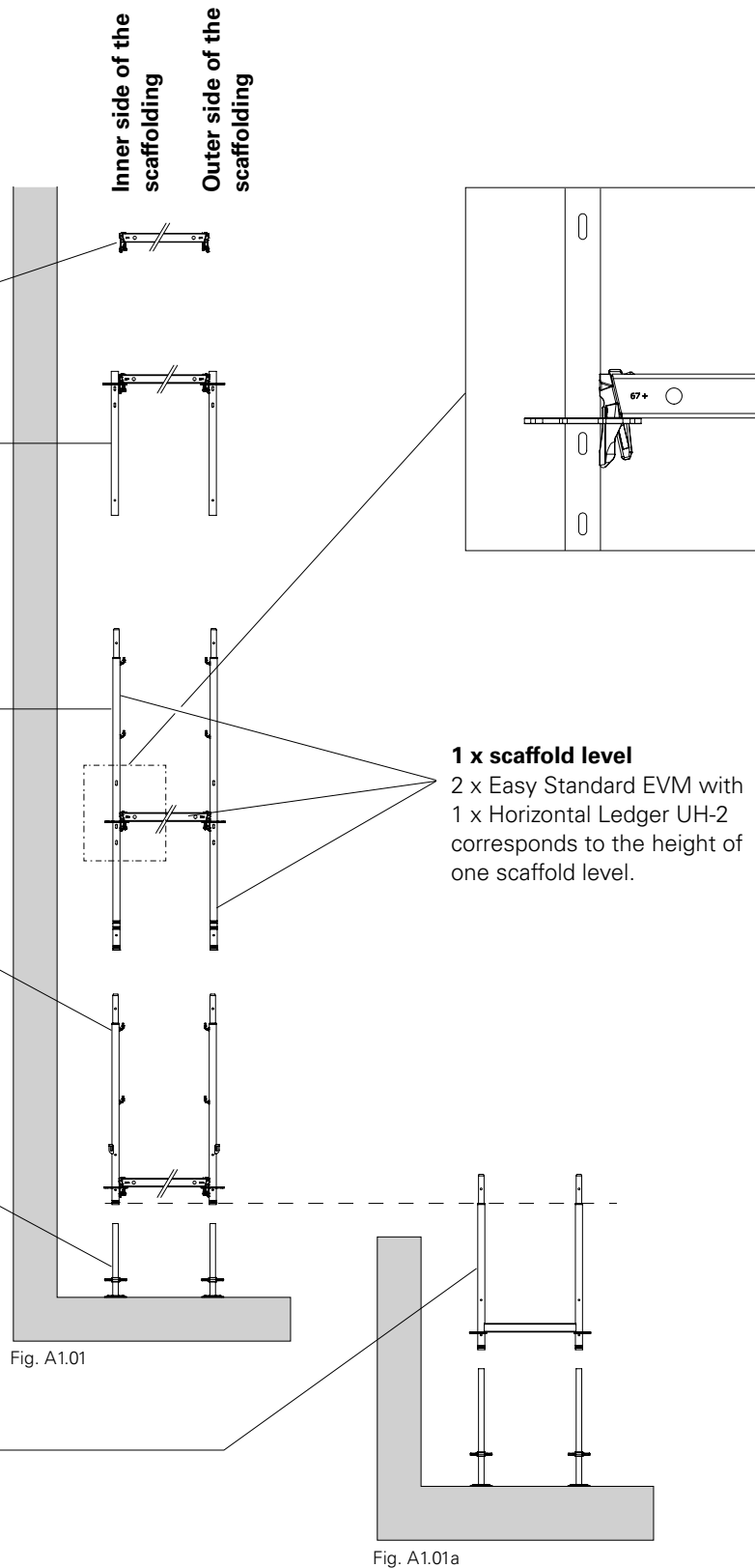

Fig. A1.01

Fig. A1.01a

Easy frame variant

For the comprehensive description of the frame variant, see the Instructions for Assembly and Use for the PERI UP Easy Facade Scaffolding 67 and 100, frame variant.

Head Frame EVH

The long tube (outer tube) forms the outer side of the scaffolding.
The short tube (inner tube) forms the inner side of the scaffolding.

Tube EVR 150

Assembly always takes place on the inner side of the scaffolding.

Easy Frame EVF

The long tube (outer tube) forms the outer side of the scaffolding.
The short tube (inner tube) forms the inner side of the scaffolding.

Base Frame EVB

The short tube (outer tube) forms the outer side of the scaffolding.
The long tube (inner tube) forms the inner side of the scaffolding.

Base Spindles UJB

Available in two different max. spindling lengths (including plate and quick jack nut)

- Base Spindle UJB 38-50/30 with red quick jack nut:
max. 35 cm spindling length.
(Fig. A1.01)
- Base Spindle UJB 38-80/55 with yellow quick jack nut:
max. 60 cm spindling length
(Fig. A1.01a)

Optional

Base Compensation EVA

available in 0.50 m and 1.00 m compensation heights. (Fig. A1.01a)

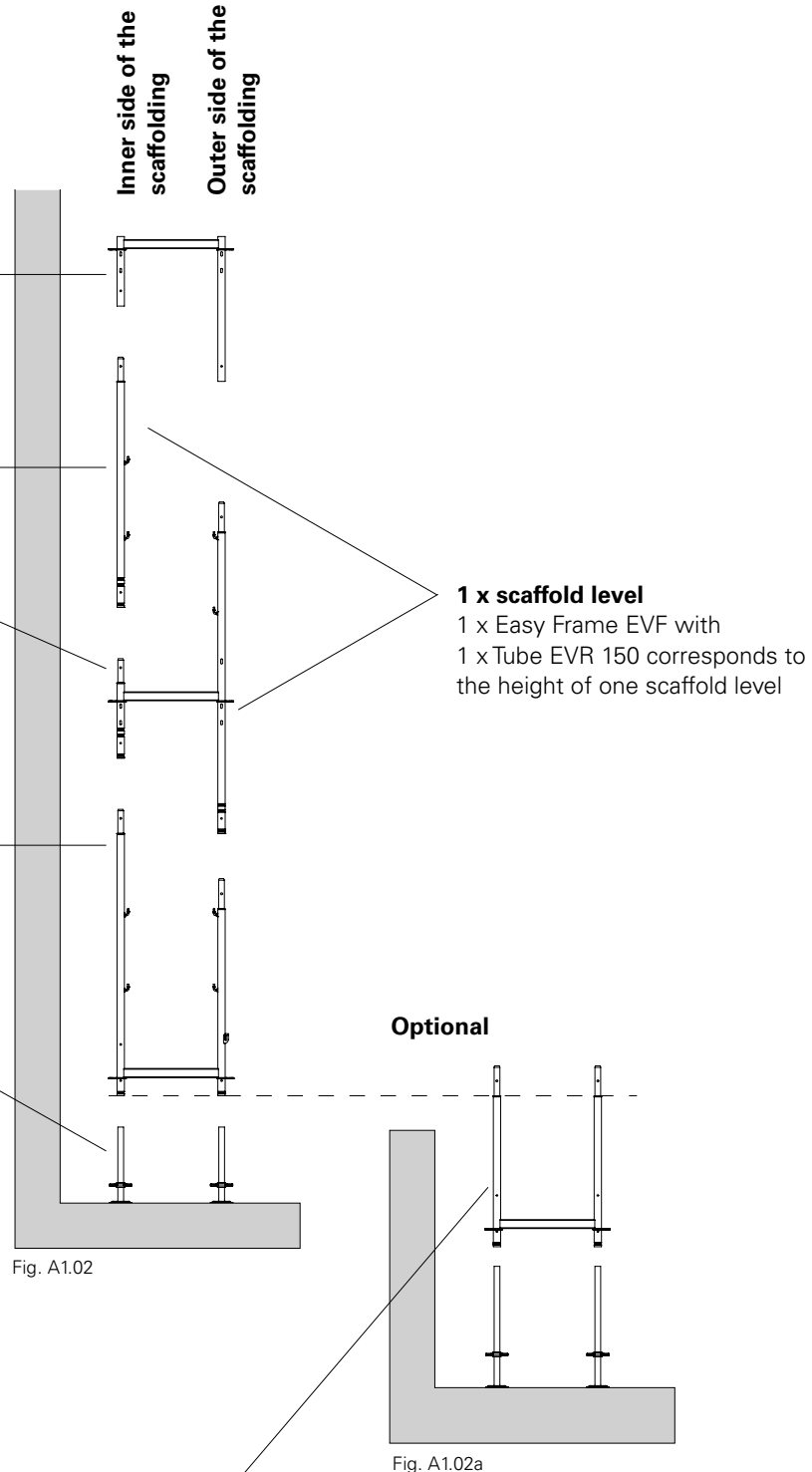

Fig. A1.02

Fig. A1.02a

Wedges (**94.1**) are used with various components, e.g. horizontal ledgers (**94**), console brackets (**62**) or supports (**61**), for connecting purposes.

Horizontal Ledger Assembly

Other wedge connections are assembled in the same way.

1. Place Horizontal Ledger UH-2 (**94**) or UHV-2 diagonally on both rosettes and set vertically. (Fig. A2.01)
2. Press the horizontal ledger down onto the rosette up to the stop.
→ Wedges (**94.1**) drop into the rosette and thus already hold the component securely.
If the wedge does not fall, push the wedge nose (**94.2**) down from the horizontal ledger by hand. (Fig. A2.01a)

3. Secure the wedges with a jarring blow using a 500 g hammer.
→ Horizontal ledger is installed. (Fig. A2.03)

Loosening the wedge connection:

1. Hit the wedge from below with a hammer.
2. Lift out the wedge and place it on the horizontal ledger together with the wedge nose. (Fig. A2.01a)

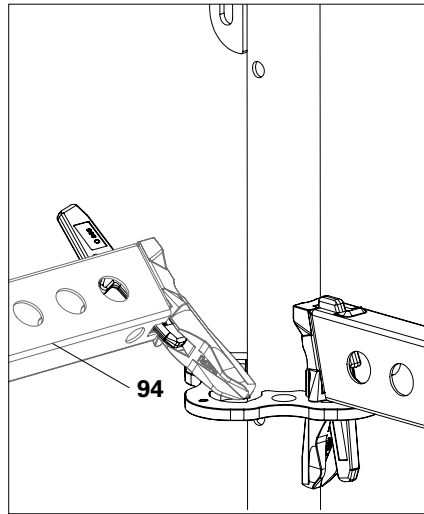

Fig. A2.01

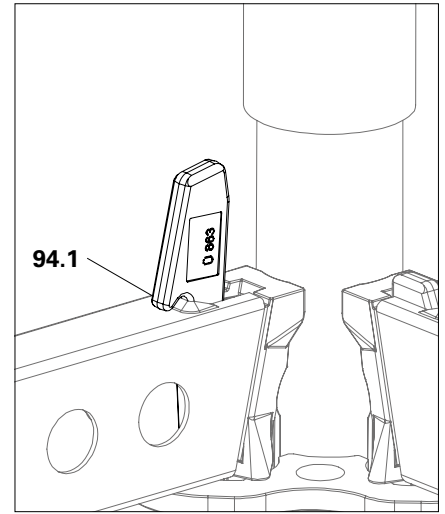

Fig. A2.01a

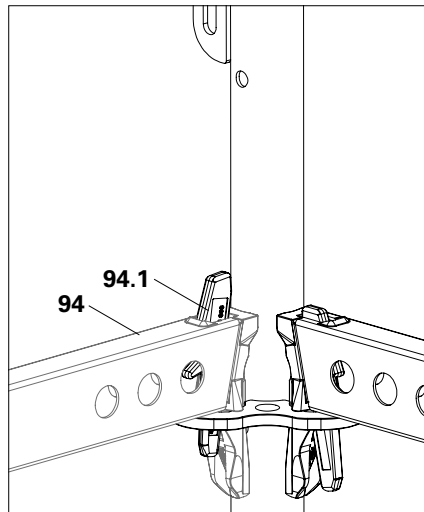

Fig. A2.02

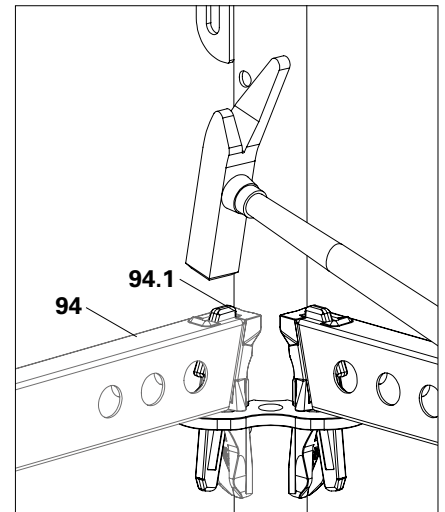

Fig. A2.03

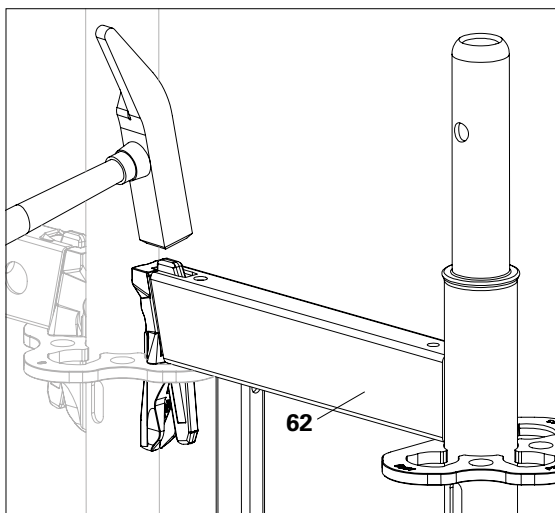

Fig. A2.04

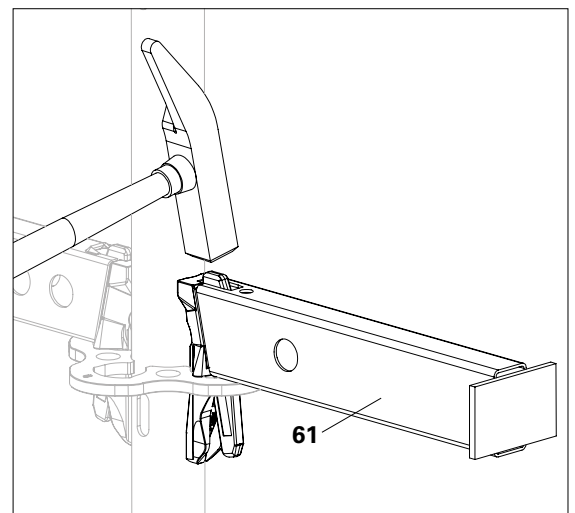

Fig. A2.05

Stair Guardrails EAG

The Stair Guardrail EAG (**77**) is used in conjunction with Locking Pin EAG (**79**) as advanced guardrail for all staircases in the PERI UP Easy system.

Assembly

1. Attach the Stair Guardrail EAG with labyrinth (**77.1**) to the upper guardrail hook and pull it up to the stop. (Fig. A3.01a + A3.01b)
 2. Attach the stair guardrail with key-hole (**77.2**) to the lower guardrail hook. (Fig. A3.01c)
 3. Fit the second stair guardrail post in the same way.
 4. Connect both Stair Guardrails EAG with 2 Locking Pins EAG (**79**) through the post holes (**77.3**).
- Stair Guardrail EAG is installed and secured.
(Fig. A3.02)

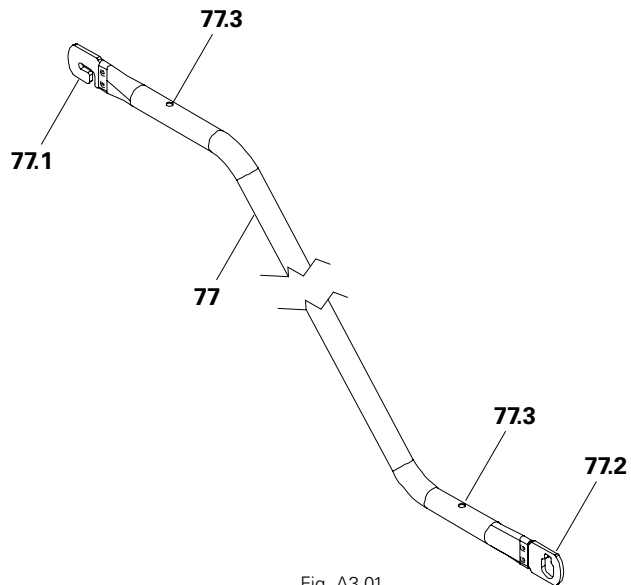

Fig. A3.01

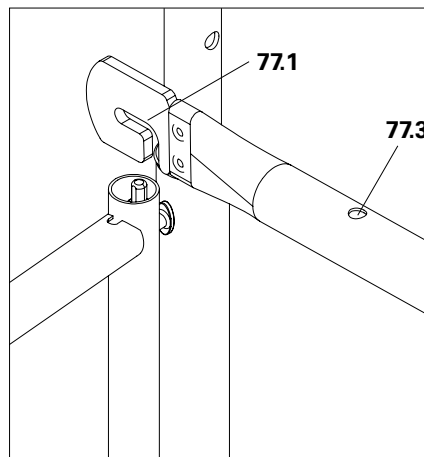

Fig. A3.01a

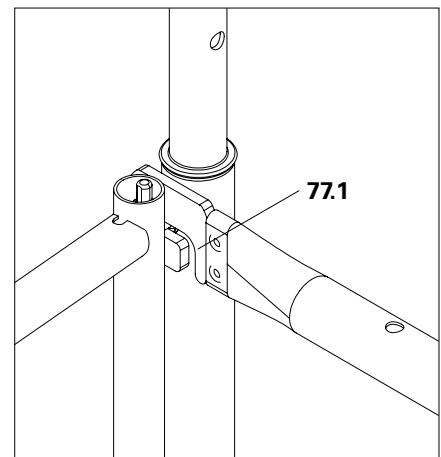

Fig. A3.01b

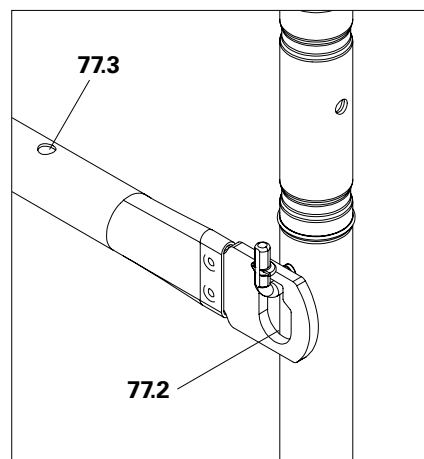

Fig. A3.01c

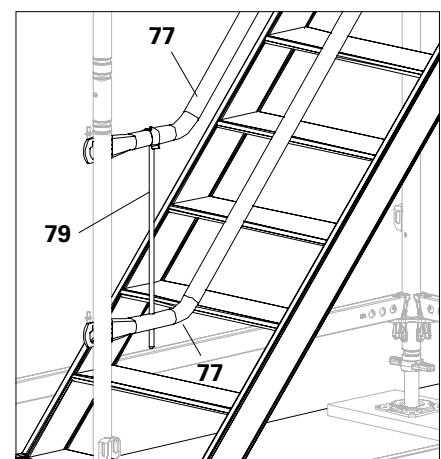

Fig. A3.02

Guardrail Post EPG

Assembly

1. Turn the connecting pieces (**51.1**) of the guardrail post horizontally and position them on the guardrail hooks. (Fig. A3.03a)
2. Align the slot (**51.2**) with the guardrail hook (**22.1**) and insert. (Fig. A3.03b)

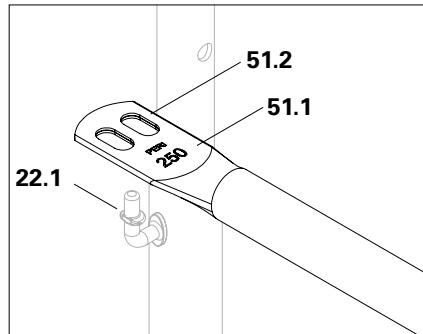

Fig. A3.03a

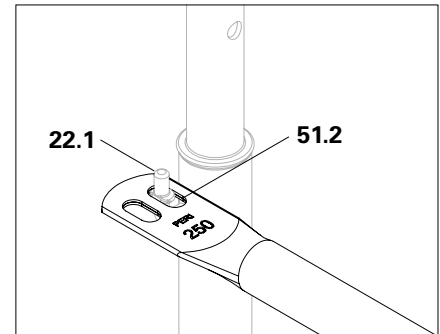

Fig. A3.03b

3. Release the guardrail post.
→ The guardrail post drops into a vertical position and is secured. (Fig. A3.03c)



- For assembly and dismantling, first insert or detach one side, then the other side.
- Assembly on the Easy Frame EVF, Guardrail Post EVP, Easy Standard EVM 200 and frame variant is carried out in the same way.

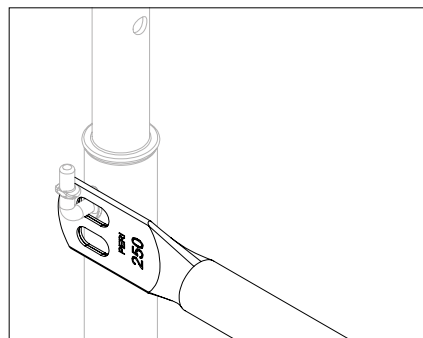

Fig. A3.03c



Note

Stability compromised!

- ⇒ Do not attach any loads (e.g. materials) to the guardrails nor place any loads on the guardrail posts!

Advanced guardrail

The lateral protection is always assembled in front.

For the assembly procedure, see also Chapter "Easy standards and guardrail post" on page 57.

Assembly can also be carried out in a "double-advanced" manner with guardrails and intermediate guardrails. e.g. for a material acceptance bay. (Fig. A3.04b)



If the maximum permissible distance to the building is exceeded, you should also fit the advanced guardrail on the inner side of the scaffolding. (Fig. A3.04c)

Observe national laws and regulations.

Assembly

1. Turn and attach the Easy Standards EVM in such a way that the guardrail hooks face inwards.
 2. Attach the Guardrail Posts EPG (51) to the Easy Standard (22a) and place them on the deck with the other side facing down.
 3. Set the second Easy Standard (22b) down on the deck and attach the free guardrail post side to the guardrail hook.
 4. Attach the Easy Standard (22b) to the scaffold together with the guardrail posts.
- The inner lateral protection is installed.

(Fig. A3.04c)



As an alternative to the inner guardrail, mount suitable console brackets on the inner side of the scaffolding with end protection.

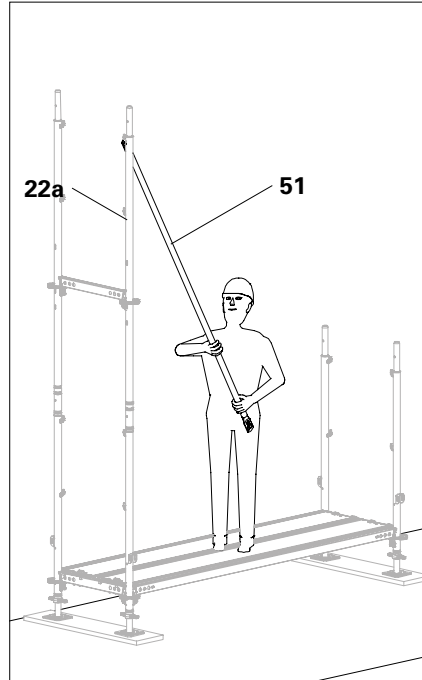

Fig. A3.04a

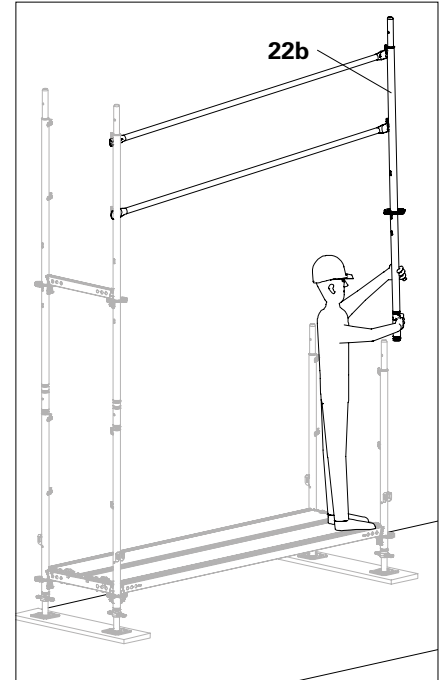

Fig. A3.04b

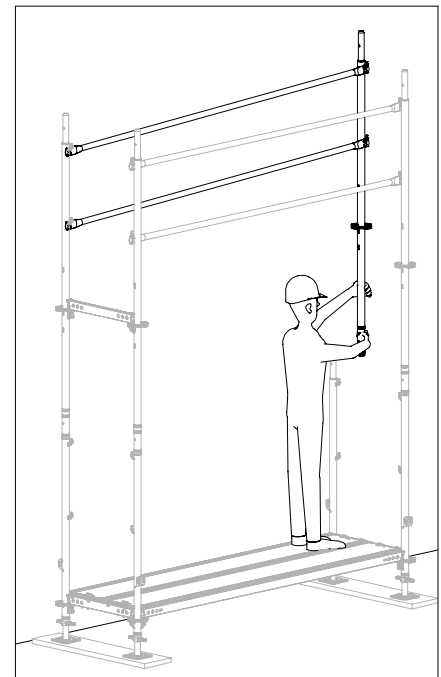

Fig. A3.04c

Wood toe board/steel toe board



In the event of high winds, the Toe Boards UPY and the Toe Boards UPF require additional reinforcement with suitable means.

Wood Toe Board UPF

Toe Boards UPF are correctly installed when each PERI logo is legible.

Assembly

1. Insert the Toe Board UPF (56) on one side with the end piece on the Easy Standard EVM (22).
 2. Lower onto the deck.
 3. Raise the other side so that the second end piece can be fitted onto the other Easy Standard.
- (Fig. A3.05)

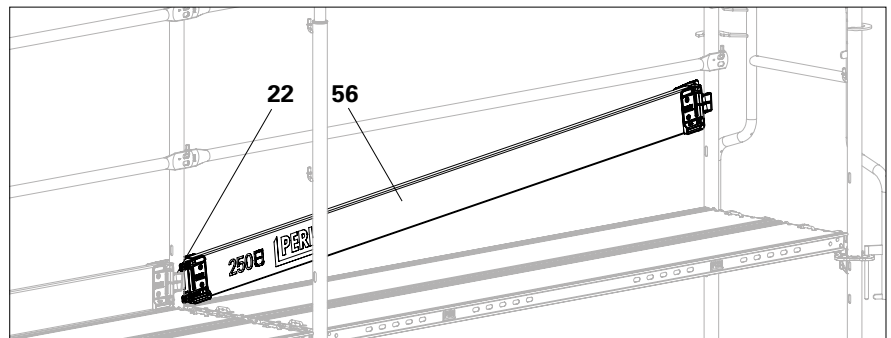

Fig. A3.05

4. Lower the toe board onto the deck.
→ The toe board is now installed.
- (Fig. A3.06)



- Assembly on the Easy Frame EVF, Guardrail Post EVP, Tube EVR 150, Easy Standard EVM 200 etc. is carried out in the same way.
 - For corners, turn the toe boards so that the retaining lugs (56.2) of the end pieces engage with each other.
- (Fig. A3.06a)

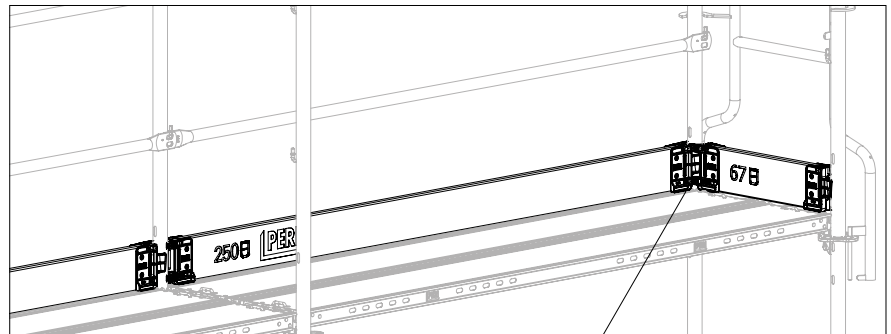

Fig. A3.06

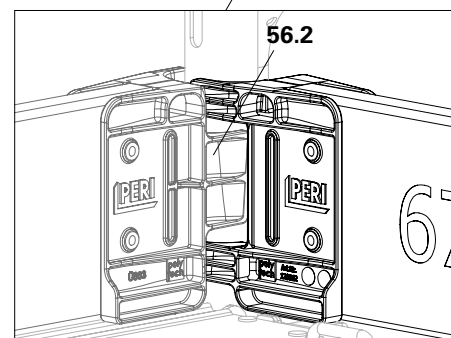

Fig. A3.06a

Toe Board UPY

Using Toe Board UPY (**57**) is optional.

Assembly in the bay

1. Turn the support bracket (**57.1**) downwards.
2. Turn the trapezoid box (**57.2**) **outwards**. (Fig. A3.07)

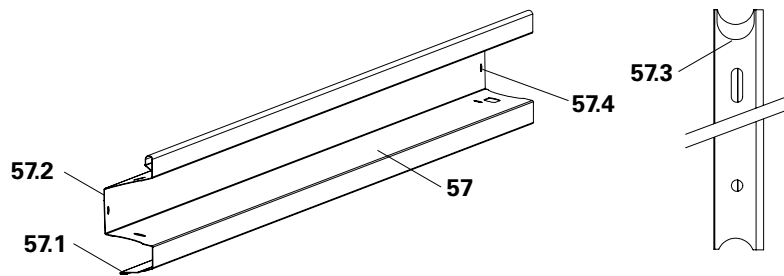

Fig. A3.07

3. Insert Toe Board UPY (**57**) from the inner side of the scaffolding to the right. The larger tube section (**57.3**) is on the right.
4. Raise the toe board on the left-hand side until it rests on the tube (**22**).
5. Lower the toe board onto the deck.
→ The toe board is installed.
(Fig. A3.08)

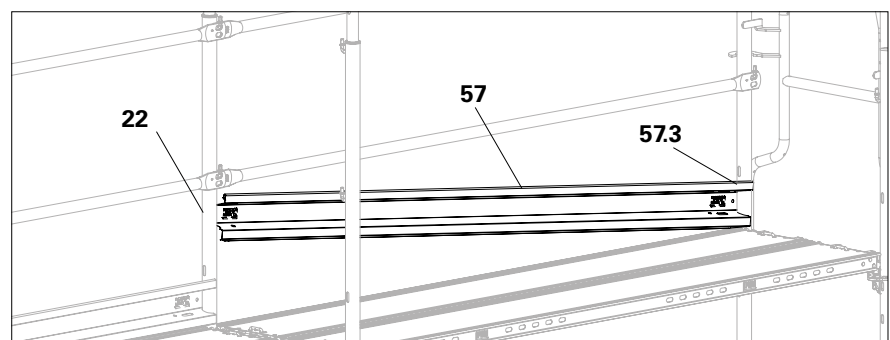

Fig. A3.08

Assembly around a corner:

1. Turn the support bracket (**57.1**) downwards.
2. Turn the trapezoid box (**57.2**) inwards.

- On a right-hand corner:
 3. Insert Toe Board UPY (**57**) from the outside-left first of all. The larger tube cut-out (**57.3**) is on the left. (Fig. A3.09)
 4. Raise the Toe Board UPY on the right-hand side and position it on the second tube.
 5. Lower the toe board onto the deck. → The toe board is installed. (Fig. A3.10)

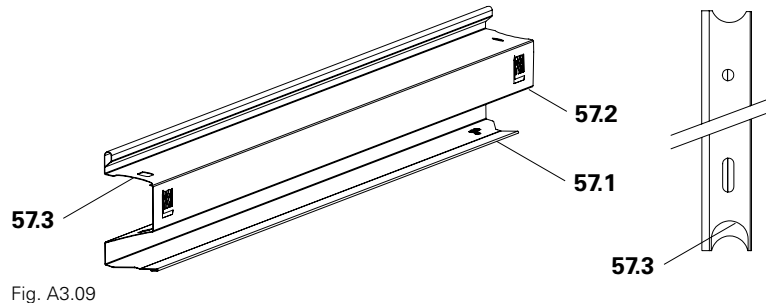

Fig. A3.09

- On a left-hand corner:
 3. Insert Toe Board UPY (**57**) from the outside-left first of all. The larger tube cut-out (**57.3**) is on the left. (Fig. A3.09)
 4. Raise the Toe Board UPY (**57a**) which has already been mounted in the bay.
 5. Place the Toe Board UPY (**57**) on the second tube and simultaneously insert it into the trapezoid box (**57.2**) of the toe board in the straight scaffolding bay.
 6. Lower the toe boards simultaneously. → The toe board is installed. (Fig. A3.11)

Right corner

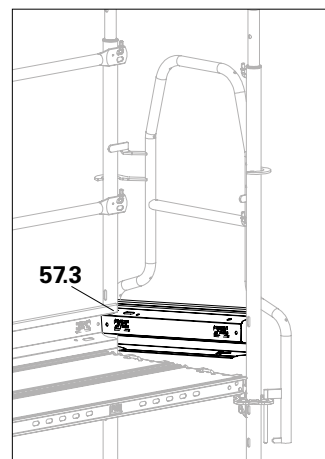

Fig. A3.10

Left corner

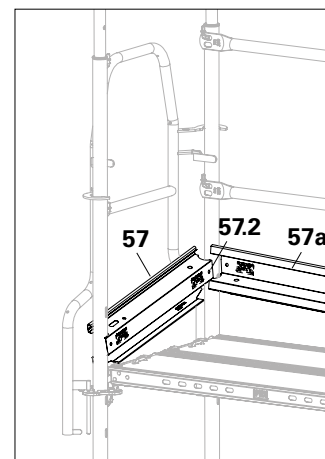

Fig. A3.11

End Guardrail UPA in advance

The end guardrail in advance is continuously mounted from a safe and secure position as system-integrated end protection for the next scaffolding bay. It can remain or be replaced by End Guardrails EPF. See the next page.

Assembly

1. Guide the end guardrail in advance (**52**) outwards around the end frame. The pegs (**52.1**) should then be pointing towards the inner side of the scaffolding. (Fig. A3.12a)
2. Swing the leading end guardrail to the left so that the fork (**52.2**) engages around the inner tube (**22**). (Fig. A3.12b)

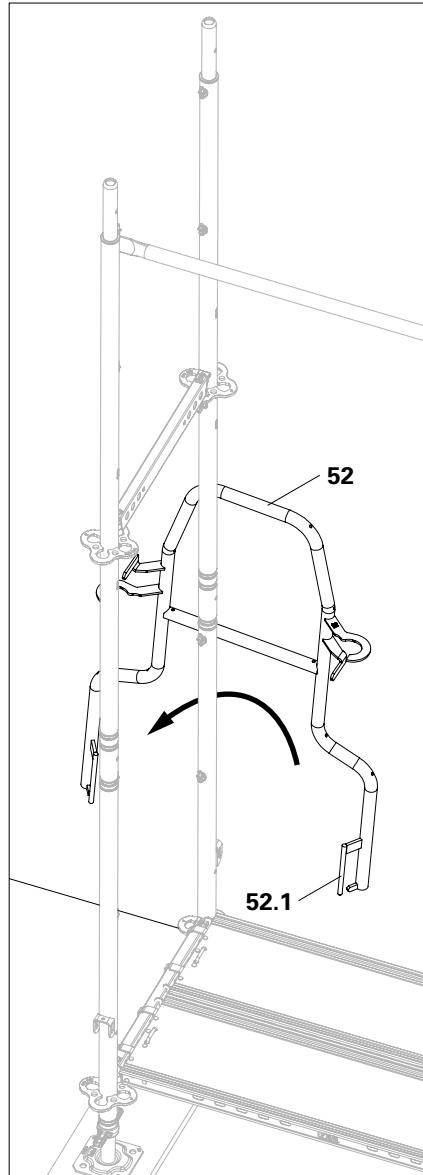

Fig. A3.12a

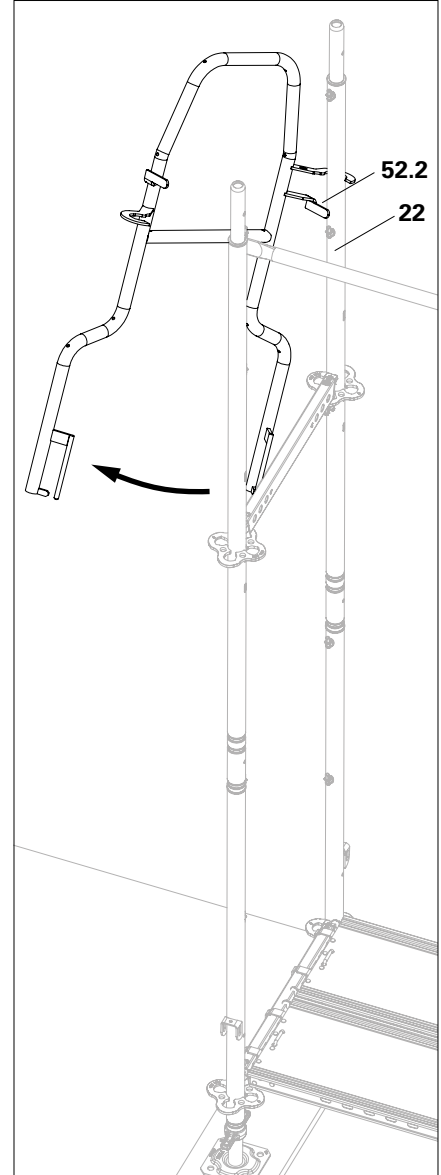

Fig. A3.12b

3. Swing the end guardrail in advance back and hook the second fork (52.2) over the outer tube (22a). (Fig. A3.12c)
 4. Raise the end guardrail in advance and insert the pegs (52.1) into the brace adapter (22.5) of the rosette from above. Lower the end guardrail in advance as far as it will go. (Fig. A3.12d)
- End Guardrail UPA in advance is now installed. (Fig. A3.12d)

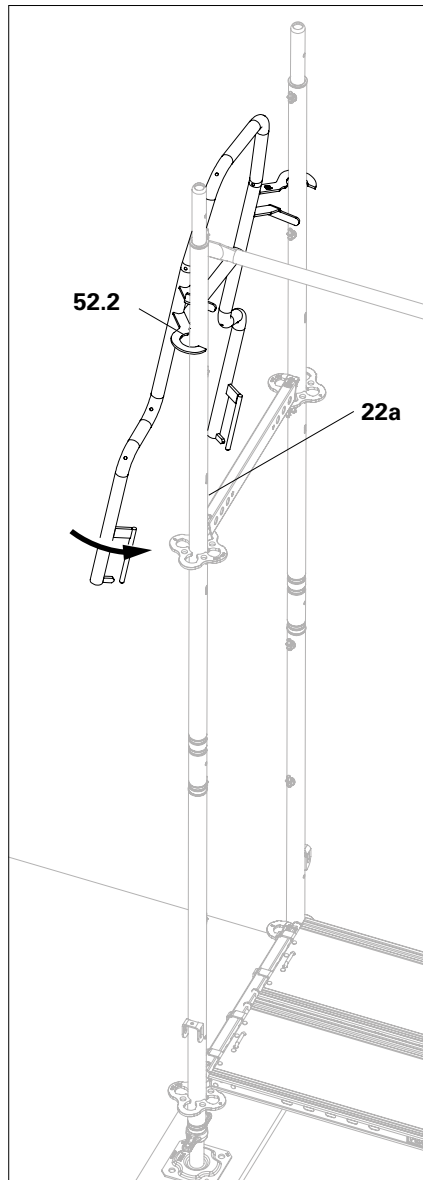

Fig. A3.12c



The End Guardrail UPA can also be mounted on the inner side of the Easy Frame. (Not in connection with attached console brackets with decks)

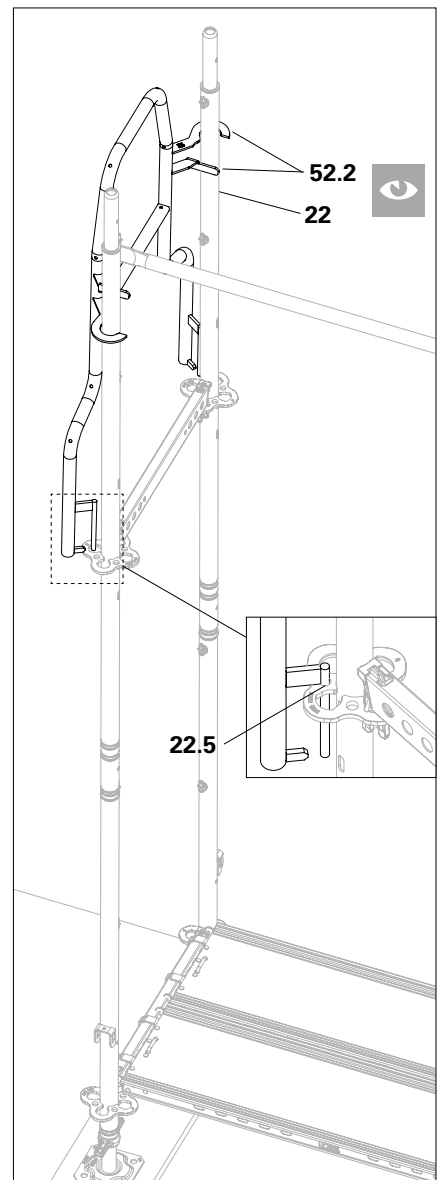

Fig. A3.12d



Is the fork (52.2) enclosed around the Easy Standard EVM (22)?

End Guardrail EPF

Install the End Guardrail EPF (54) from a secured position.
 Install the Guardrail Post EVP or Easy Standard EVM in such a way that the guardrail hook is pointing towards the middle of the scaffolding.

Assembly

1. Push the fork (54.1) onto the tube positioned opposite. (Fig. A3.13)
 2. Attach both slots (54.2) to the guardrail hooks. (Fig. A3.14)
 3. Lower the End Guardrail EPF as far as possible.
 4. Add toe board to the lateral protection.
- End Guardrail EPF is now installed. (Fig. A3.15)

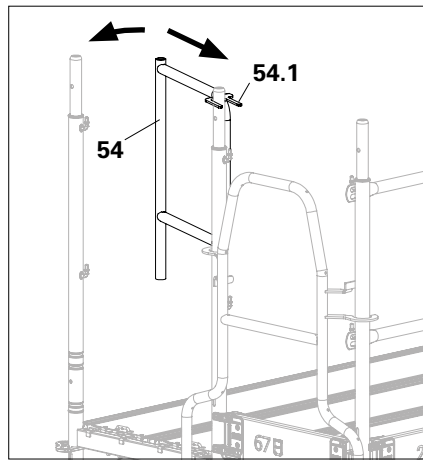

Fig. A3.13

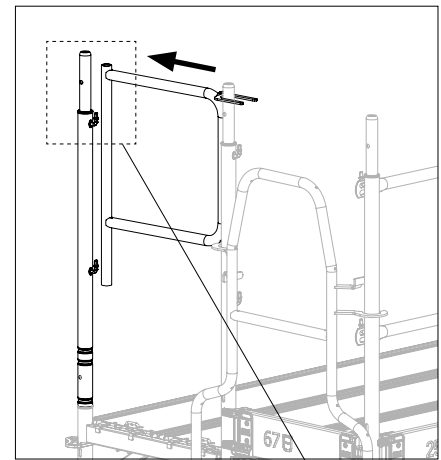

Fig. A3.14



Has the end guardrail been lowered as far as it will go?

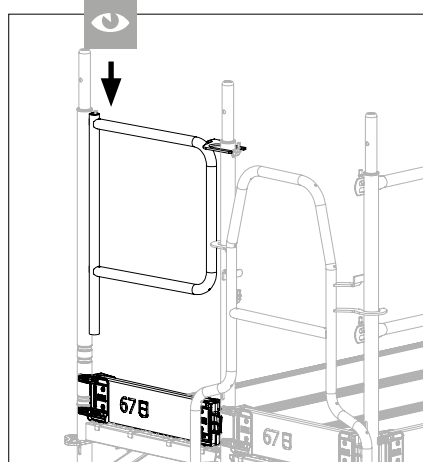

Fig. A3.15

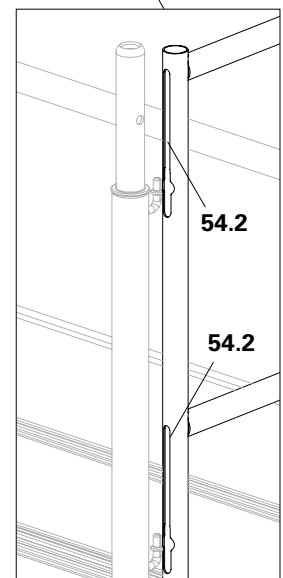

Fig. A3.14a

End Guardrail in Advance EPF



Warning

Incorrect handling can cause the assembly to come loose and components to fall. This could seriously injure or kill people!

- ⇒ Only take hold of the assembly by the Easy Standard EVM.
- ⇒ Do not set the pre-assembled assembly down, but instead hold it vertically and move it into the assembly position straight away and install it.



- In the edge bay, the lateral protection must first be mounted in a “double-advanced” manner.
- It is not possible to install an inner guardrail.

Assembly

1. Fit the first Easy Standard EVM (22) onto the scaffold.
 2. Fit the Guardrail Posts EPG (51) in a double-advanced manner in the edge bay.
 3. Pre-assemble the End Guardrails EPF (54) on the second Easy Standard (22a).
 4. Place the Easy Standard with its pre-assembled end guardrail on the scaffold in the assembly position and attach the fork (54.1) to the previously assembled standard. (Fig. A3.16a)
 5. Fit the standard onto the inner side of the scaffold.
- The End Guardrail EPF is mounted in advance.
(Fig. A3.16b)

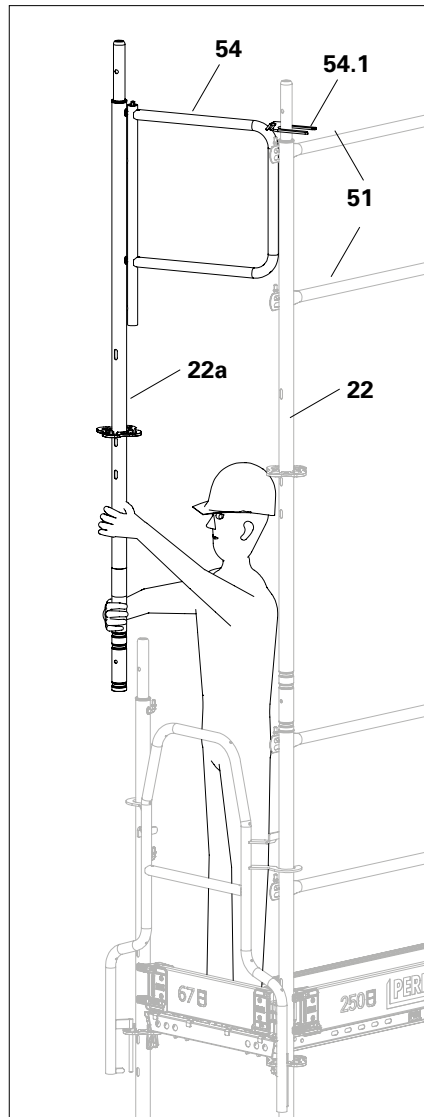

Fig. A3.16a

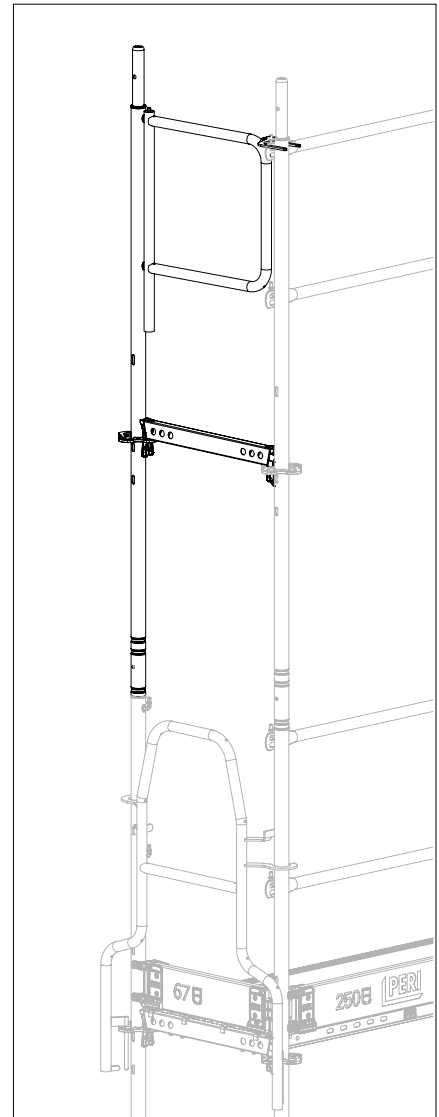

Fig. A3.16b

Replacing end guardrails

The End Guardrail in Advance UPA-2 can be replaced with an End Guardrail EPF at every level. On the upper scaffold level, End Guardrail UPA-2 can remain in place until the scaffolding is dismantled. Assembly is carried out from a safe position. Observe national regulations.

Assembly

1. Installation of the End Guardrail in Advance UPA-2 (52) for the next level takes place from a safe position, see previous section.
 - Once the next scaffold level is complete:
 2. Install End Guardrail EPF (54) in addition to End Guardrail UPA-2, see previous section.
 - The End Guardrail in Advance UPA-2 can be dismantled again and used for the next level.
- (Fig. A3.17a + A3.17b)

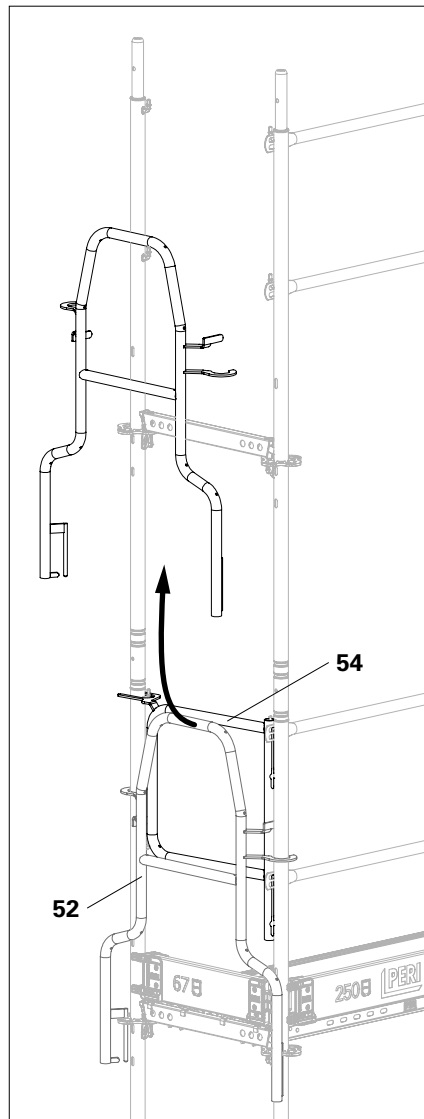

Fig. A3.17a

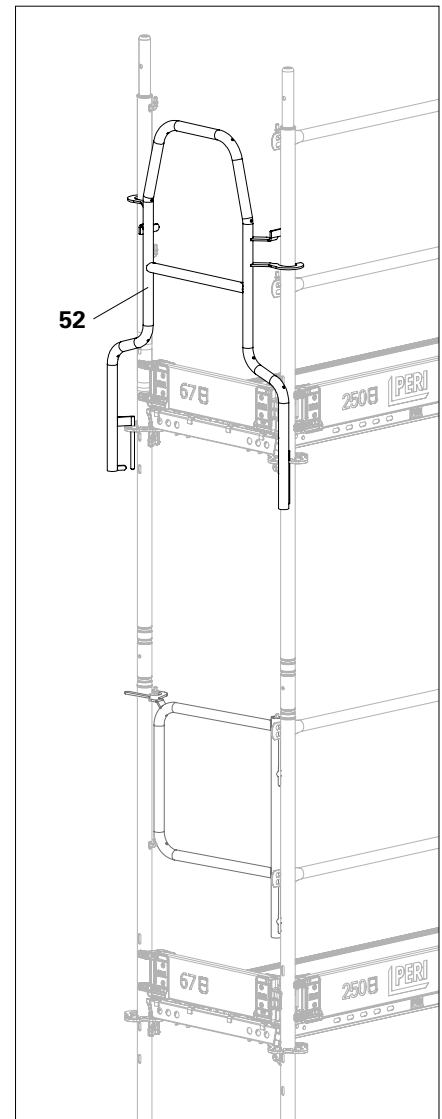

Fig. A3.17b

Decks



Note

Stability compromised without system decking.

⇒ System decks are bracing components and must, therefore, be installed across the full scaffolding width and in every scaffold bay!

Various system decks are available for PERI UP Easy:

- For width class W06 ≥ 60 cm
 - Steel Deck EDS 33 (30),
 - Aluminium Deck EDA 67 (31)
 - Composite Deck EDC 67 (32)
 - Combi Deck EDW 67 (37).
- For width class W09 ≥ 90 cm
 - Steel Deck EDS 33 (30).

All decks have integrated lift locks.

→ Installation of the Steel Deck EDS is shown below.

Assembly

1. Pick up the deck (30) in the middle, edge it to the side and lift it over both Horizontal Ledgers UH-2 (98).
2. Place the deck on the horizontal ledgers one after the other.
3. Lift locks (30.1) fall under the horizontal ledger and secure the deck.

→ The deck is now installed.

(Fig. A4.02)



The access decks and entry platforms are assembled in the same way.

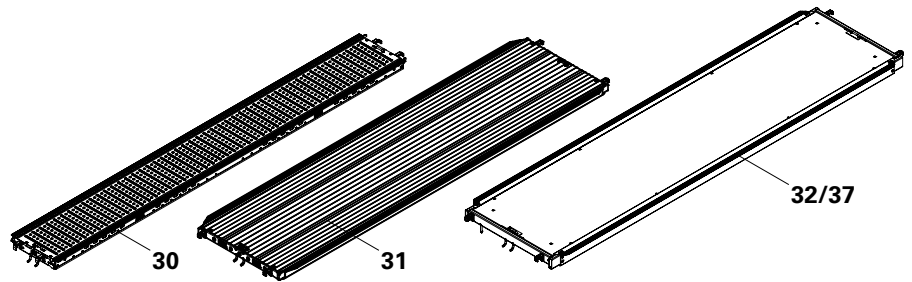

Fig. A4.01

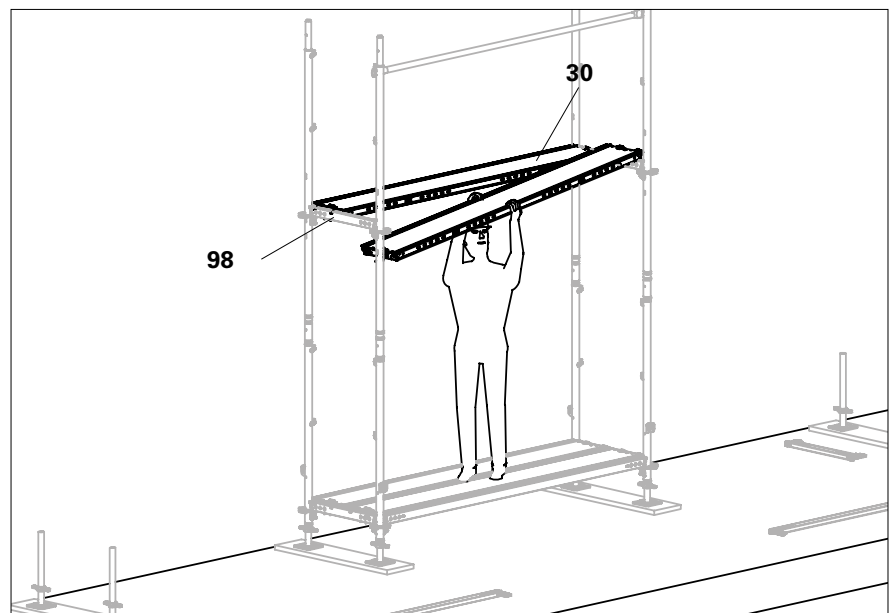

Fig. A4.02

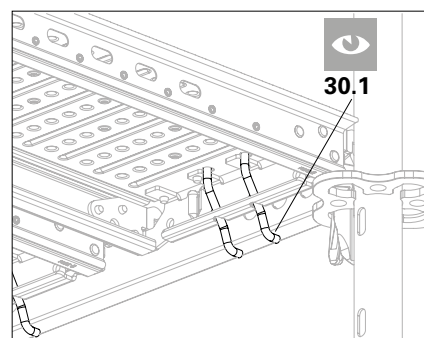

Fig. A4.03



Have all lift locks (30.1) on the deck dropped beneath the horizontal ledger? If not, lift the deck slightly and let it drop into position or operate the lift lock manually. (Fig. A4.03)

Dismantling the decking

1. On one side of the decking, pull up the lift lock to release it and lift the deck.
 2. Pull out the lift lock as far as it will go.
 3. Set the deck with the lift lock (30.1) down on Horizontal Ledger UH-2 (98). (Fig. A4.04)
 4. Lift the deck in the centre, tip it laterally on its edge, and unscrew it in a downwards direction. (not shown)
- The deck has now been removed

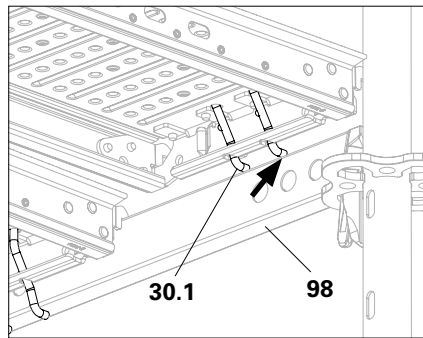

Fig. A4.04



If the deck lock is not pulled out all the way, the deck on this side of the deck falls back onto the ledger when the opposite side is lifted.

Internal access

Internal access is not possible for width class W09. See Section "External access with staircase" on page 82.



Warning

Open access hatches pose a risk of falling. A fall can result in serious injury

- ⇒ When not in use, the access hatches must remain closed!
- ⇒ Arrange the access openings alternately!



Caution

Body parts can become trapped by self-closing access hatches resulting in injuries.

- ⇒ Guide the access hatch by hand when closing, do not let it fall shut!
- ⇒ Take into consideration any other persons waiting to use the hatch!



Note

Ensure that the hatch does not exceed an angle of 95° when opened. This can lead to injuries.



Internal access by way of access decks or entry platforms is possible up to Load Class 3 (LC3).

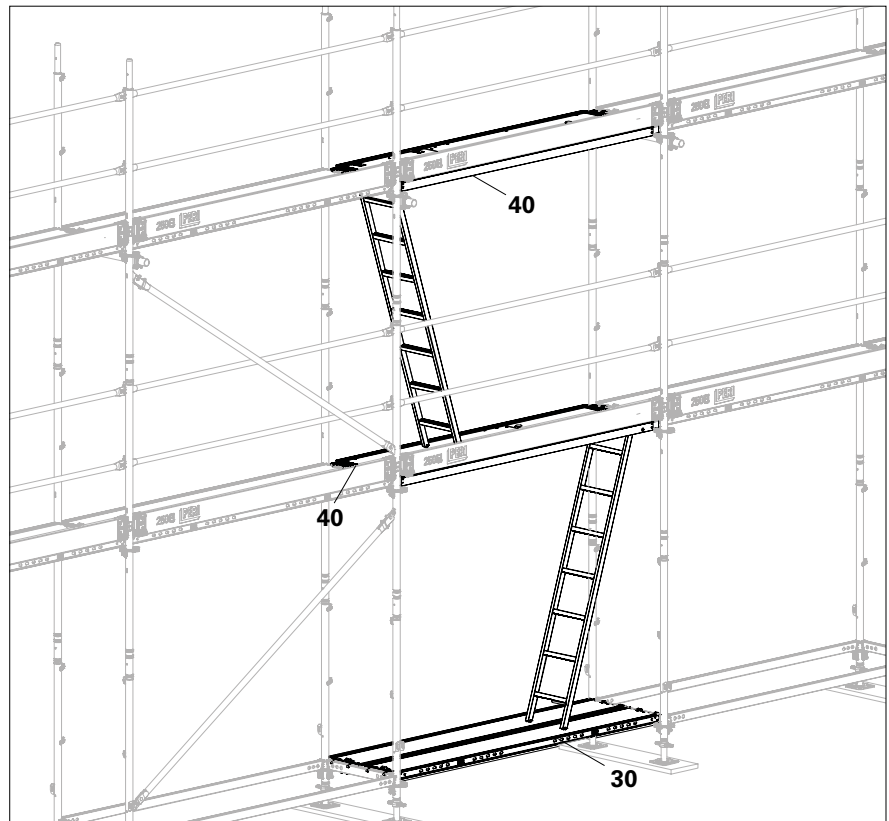

Fig. A4.05

Access deck

For bay lengths of 2.50 m and 3.00 m, install the Access Decks EAW-L, EAC-L, or EAA-L (40) (with attached access ladder) in the basic scaffold.

Assembly

1. Mount decks (30) on the bottom level as a base for the first ladder.
 2. Install an access deck (40) in the subsequent scaffold levels. See Section "Decks" on page 34.
- Access deck is installed.
(Fig. A4.05)

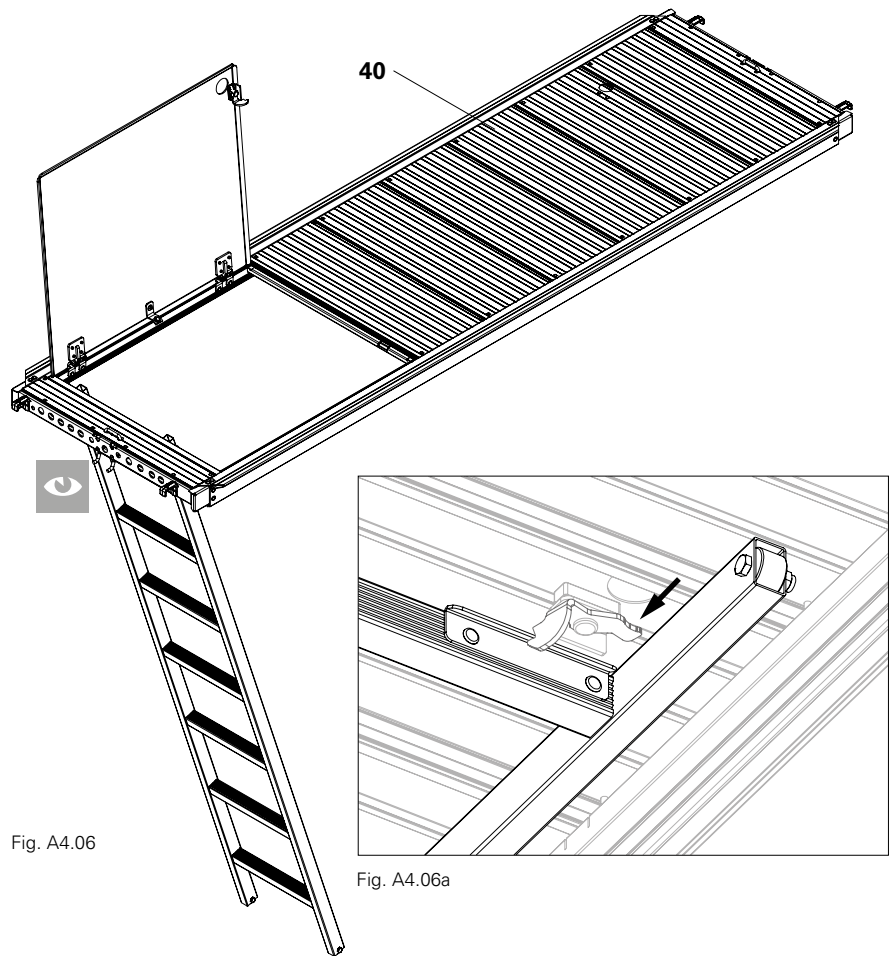

Fig. A4.06

Fig. A4.06a



- For system width 100, a front-mounted stair tower must be fitted.
- To lock and unlock the hatch and ladder, hold the spring clip down and guide the hatch or ladder by hand.
(Fig. A4.06a)

Entry platform

For 2.00 m bay lengths, install the Entry Platform EAW, EAC or EAA and Ladder UAF.

Assembly

1. Carry out the assembly process as you would for access decks.
 2. Open the access hatch and secure temporarily.
 3. Attach the ladder to the circular tube.
 4. Close the access hatch.
- The entry platform is installed.

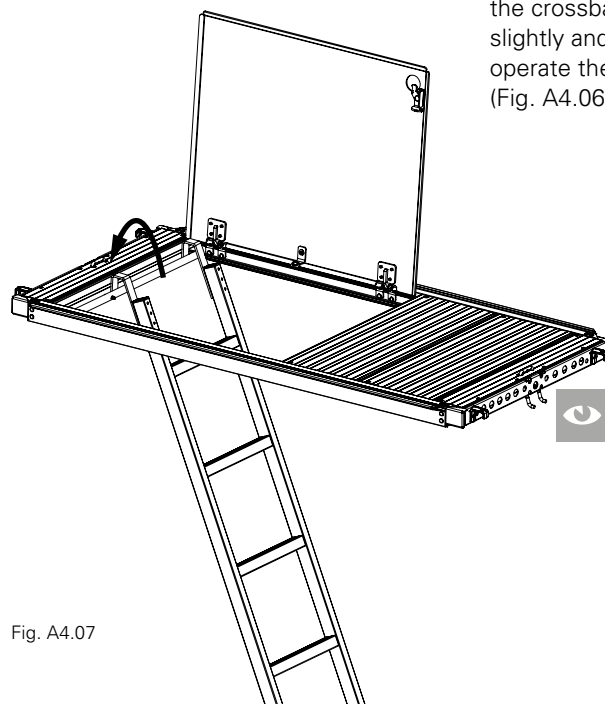

Fig. A4.07



- Have both lift locks dropped beneath the crossbar? If not, lift the deck slightly and let it drop into position or operate the lift lock manually.
(Fig. A4.06 + A4.07)

Face braces

Note

Stability compromised due to missing face braces and/or horizontal ledgers.
 ⇒ Comply with the tie pattern!

Diagonal bracing

- To brace the outer vertical plane, use vertical braces with a tower-like diagonal bracing arrangement. One brace may be used to brace a maximum of five bays. (Fig. A5.01)
- The exact number and position of the horizontal ledgers in the base level and the braces is given in Section tie pattern.

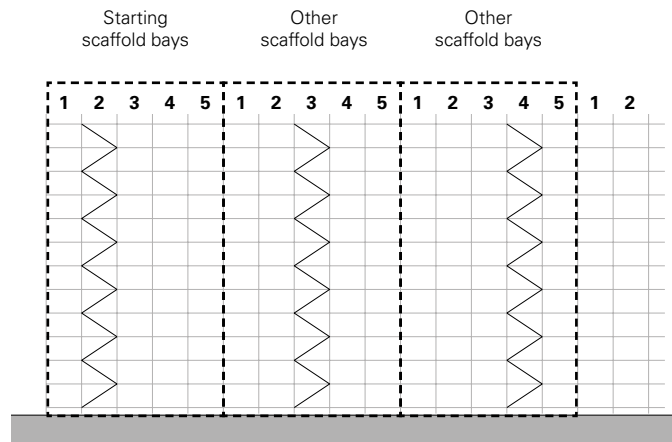

Fig. A5.01

Assembly

1. Attach the fixed brace head (20.1) to the slot (23.7).
 - In the Easy Base Standard EVS (23) see Fig. A5.02+ A5.02a
 - In the Easy Standard EVM (22) see Fig. A5.02+ A5.02b

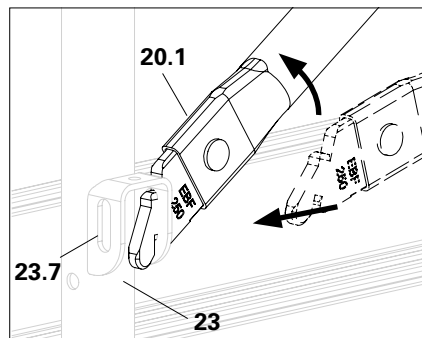

Fig. A5.02a

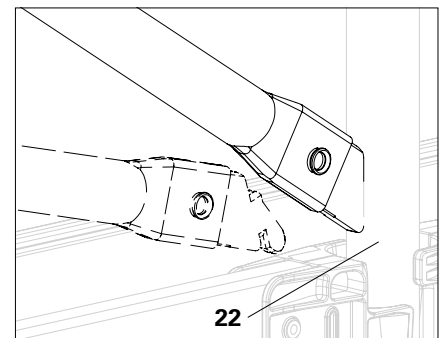

Fig. A5.02b

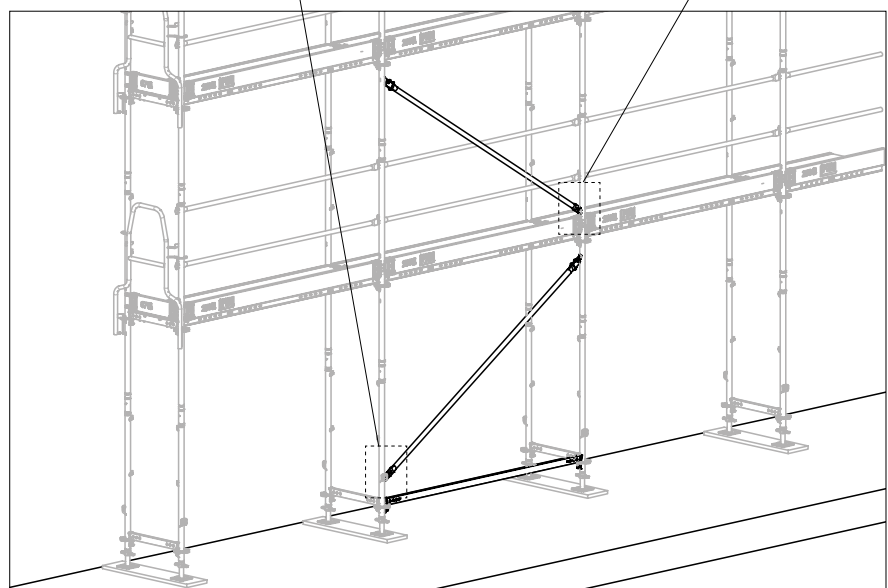

Fig. A5.02

2. Lift the Face Brace EBF (**20**) on the other side up to the slot.
3. Push the safety clip (**20.3**) upwards, swivel the Brace Head (**20.2**) and insert into the elongated hole (**22.8**) of the Easy Standard EVM.

(Fig. A5.03)

4. Press the Face Brace EBF (**20**) downwards and secure with the locking ring (**20.3**).

→ The face brace is now installed.

(Fig. A5.04)

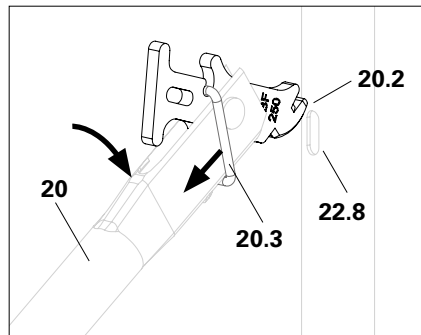

Fig. A5.03

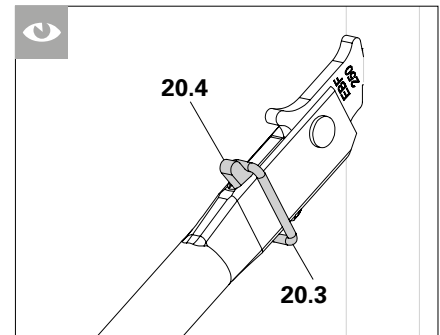

Fig. A5.04



Is the locking ring (**20.3**) at the lower limit stop (**20.4**)? If not, push it as far as possible manually! (Fig. 5.04)

Internal braces

Internal bracing is assembled in the same way.

(Fig. A5.05)

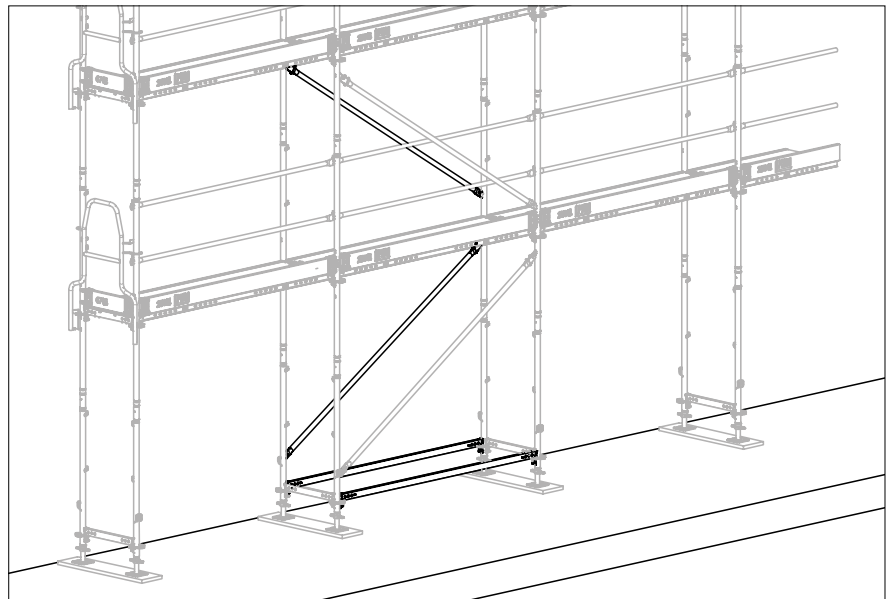

Fig. A5.05

General

For PERI UP Easy, Console Brackets ECM (62) (with rosette and 50 cm standard) and Supports UC (61) (without rosette and standard) are available.

If a Guardrail Post EVP 100 is required for the lateral protection (e.g. for installation of end guardrails), only Console Brackets ECM (62) are to be used.

Console brackets available:

Console Bracket ECM 33 (62)
 Console Bracket ECM 67
 Console Bracket ECM 100 (only as protection roof)

Supports:

Support UC 33 (61)
 Support UCS 33

Alternatively:

Console Brackets UCB 25 and Supports UC 25 with Decks UDG in 25 cm width.

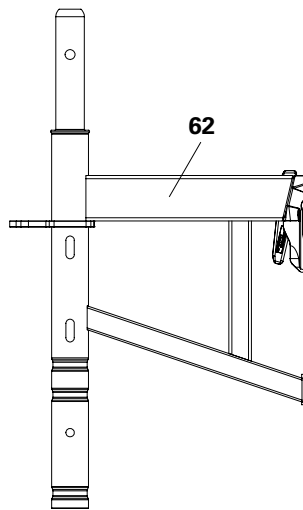

Fig. A6.01

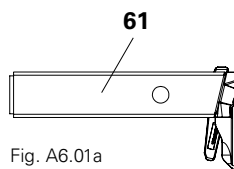

Fig. A6.01a



- External console brackets may only be mounted in any one scaffold level. When using all console bracket widths, the scaffold level on which the brackets are mounted must be additionally anchored.
- When using Console Brackets ECM 67, the scaffold level must also be anchored 4 m below the console bracket level.
- For additional ties for internal and external console brackets, see Section Tie pattern
- Observe the load classes of the decks, see Section "E1 Load-bearing capacities" on page 158.
- The surface loads or standard loads specified in each case shall apply.

Use as internal console bracket			
Supports	Bay length	Load class	F [kN]
UC 25/33	≤ 3.00 m	LC 3	-
UCS 33	≤ 3.00 m	LC 4	-
Console brackets			
UCB 25	≤ 2.50 m	LC 6	5.2
	3.00 m	LC 5	5.2
ECM 33	≤ 3.00 m	LC 6	3.9
ECM 67*	≤ 3.00 m	LC 3	2.8
ECM 33 with Support UC 33*	≤ 3.00 m	LC 3	

Use as external console bracket			
Console brackets	Bay length	Load class	F [kN]
ECM 33	≤ 3.00 m	LC 6	3.9
ECM 33 with protection panel	≤ 3.00 m	LC 3	
ECM 67	≤ 3.00 m	LC 4	2.8
ECM 67 with protection panel	≤ 3.00 m	LC 3	

* This version is not covered by the standard configuration. Separate static proof for the stability is required here.

Console brackets on the scaffold



- Console brackets are always installed from below!
- See Section "A2 Wedge connections" on page 22.

Assembling Console Bracket ECM 33

1. Attach Console Bracket ECM 33 (**62**) to rosette. The formwork half (**62.2**) must rest against the vertical tube. (Fig. A6.03)
2. Secure the wedge.
→ The console bracket is now mounted. (A6.03a)

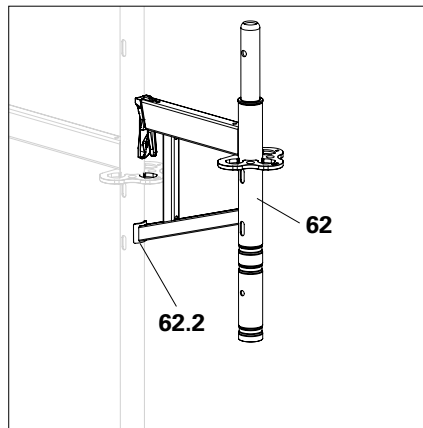

Fig. A6.03

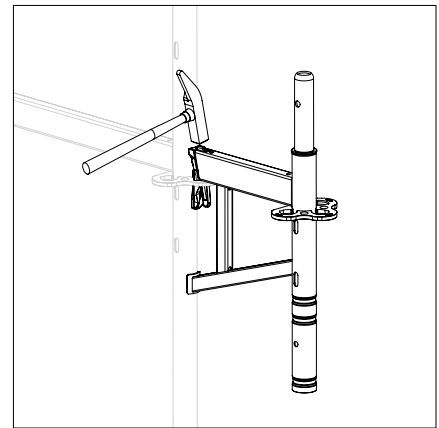

Fig. A6.03a

Console Bracket ECM 67/ECM 100

1. Connect the Console Bracket ECM 67 (**63**) or ECM 100 to the rosette (**22.4**) of the Easy Standard EVM or the Top Standard EVT 96 parallel to the scaffold. (Fig. A6.04)
2. Hold the wedge (**63.1**) up, and swing the console bracket outwards. The formwork half (**63.2**) must rest against the vertical tube. (Fig. A6.04a)

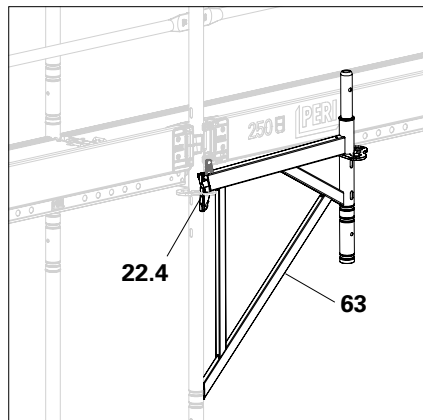

Fig. A6.04

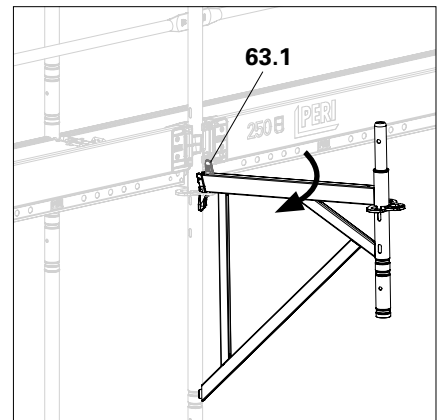

Fig. A6.04a

3. Drop the wedge into the rosette. Secure the wedge.
→ The console bracket is now mounted. (Fig. A6.04b)

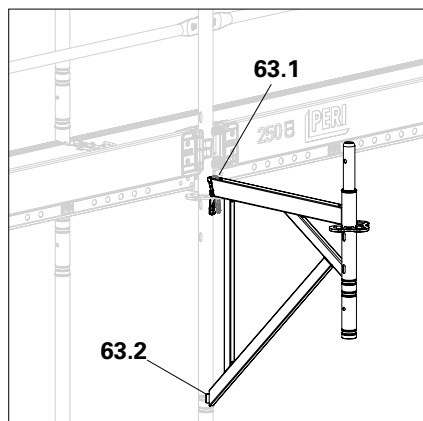

Fig. A6.04b

Console brackets with protection panel posts/guardrail posts

Position the Protection Panel Post EPS or Guardrail Post EVP on the scaffold before assembling the console bracket, and then mount together.

Alternatively, installation of the protection panel posts and guardrail posts can also be done later after the console brackets have been mounted.

Assembling the Protection Panel Post EPS on the console bracket

1. Slide the loop (67.2) of the Protection Panel Post EPS (67) onto the lower tube end of the console bracket (63). (Fig. A6.05)
2. Push Protection Panel Post EPS upwards on the Console Bracket ECM, and then attach it to the Console Bracket ECM. (Fig. A6.06 + A6.07)
3. To extend the reach, pin the protection panel post with locking pins $\varnothing 48/57$ (19).

→ The protection panel post is now pre-assembled.

(Fig. A6.07)



The hook block (67.3) must engage in the rosette!

Assembling the Guardrail Post EVP on the console bracket

1. Attach the Guardrail Post EVP to the Console Bracket ECM.
2. Disconnect the guardrail post for passing on with locking pins $\varnothing 48/57$.

→ The guardrail post is now pre-assembled.

(not shown)

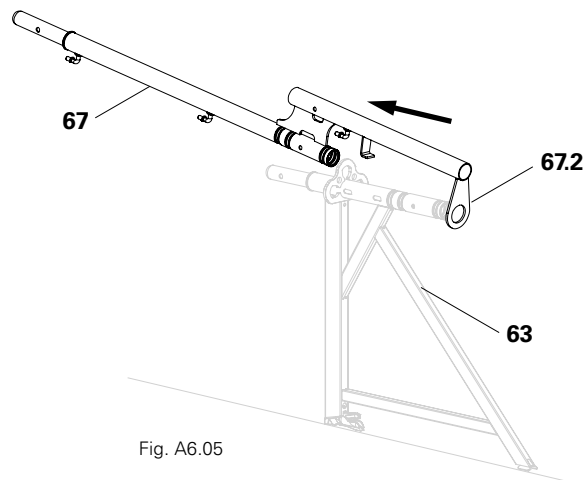

Fig. A6.05

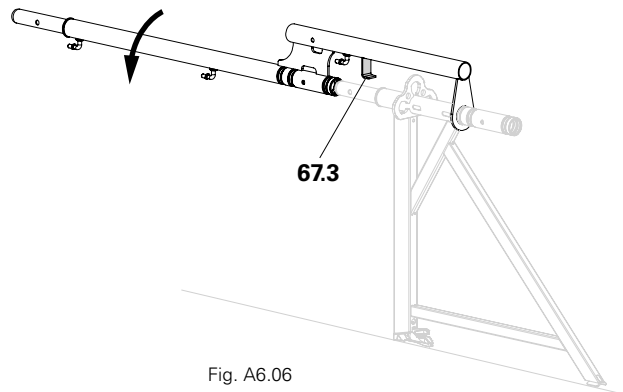

Fig. A6.06

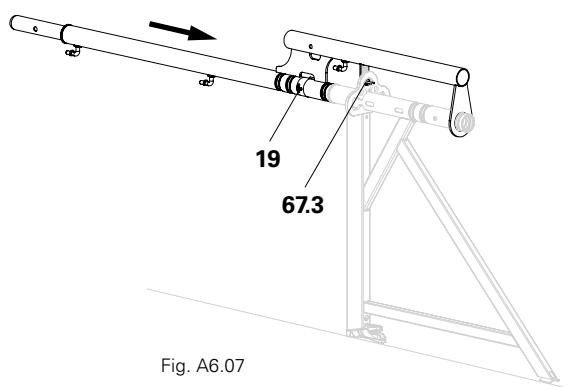

Fig. A6.07

Assembling the console brackets on the scaffold

Assembly of the console brackets with attached Protection Panel Post EPS or Guardrail Post EVP takes place by pivoting outwards as described on the previous page.
(Fig. A6.08)

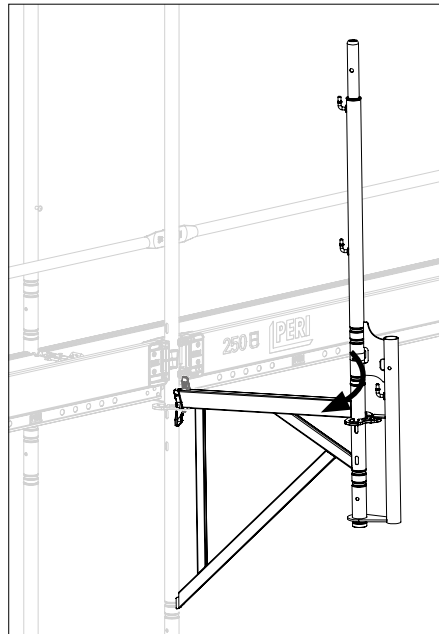

Fig. A6.08

Console brackets connected one behind the other



- Additional Console Brackets ECM 33 (62a) or Supports UC (61) can only be attached to Console Brackets ECM 33 (62). (Fig. A6.02 + A6.02a)
- Mount only one additional console bracket!
- Console brackets connected one behind the other are not covered by the standard configuration. Separate static proof for the stability is required here.

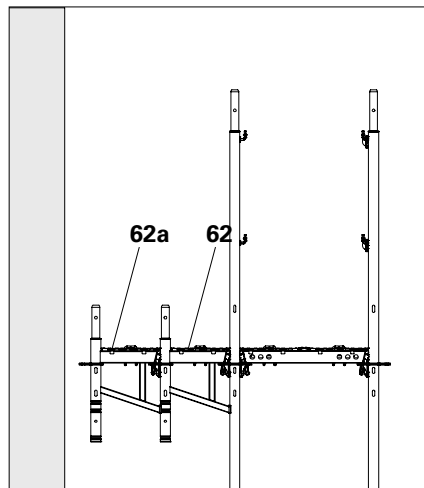

Fig. A6.02

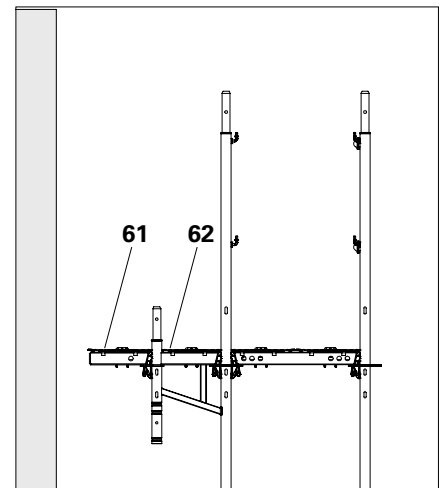

Fig. A6.02a

Assembling the ties on the scaffold



Caution

The Wall Tie Coupler EWC can become detached when subjected to movements, fall to the ground and injure persons below.

- ⇒ Do not pre-assemble the wall tie coupler.
- ⇒ Fit the Wall Tie UWT immediately.



Note

Screw closures for the couplings must be tightened with a torque of 50 Nm!

Wall Tie Holder EWC

Assembly

1. Insert the Wall Tie Coupler EWC (45) into the elongated hole (22.8) of the Easy Standard EVM or console bracket and turn it 90° downwards. Possible for single-standard and multi-standard wall ties.
→ The wall tie coupler is now installed. (Fig. A7.01 – A7.01b)

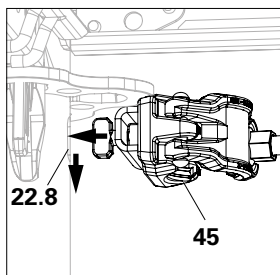

Fig. A7.01

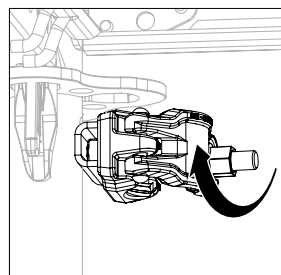

Fig. A7.01a

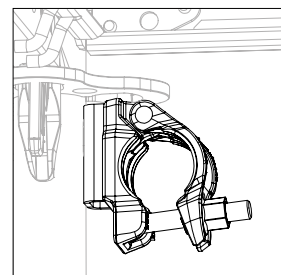

Fig. A7.01b

Wall Tie UWT

Assembly

1. Attach the Wall Tie UWT (46) to the eyebolt.
 2. Fit the Wall Tie UWT onto the Wall Tie Coupler(s) EWC (45).
- The wall tie is now installed.

(Fig. A7.02 + A7.03)

Standard couplers can also be mounted instead of Wall Tie Couplers EWC. Possible for single standard and multi-standard wall ties, as well as triangulated ties.



The wall tie coupler can be installed using different slot positions (22.8). This results in a range of possible installation angles for the Wall Tie UWT. (Fig. A7.04 – A7.04b)



Fit the Wall Tie UWT (46) as close as possible to the Horizontal Ledger UH-2 (98) in order to achieve the highest possible clearance height.

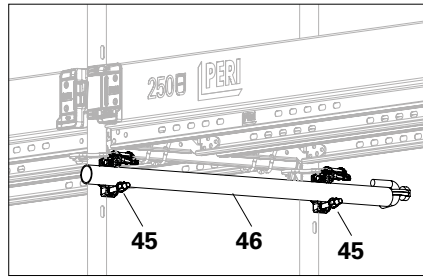

Fig. A7.02

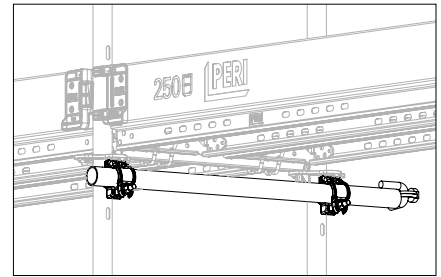

Fig. A7.03

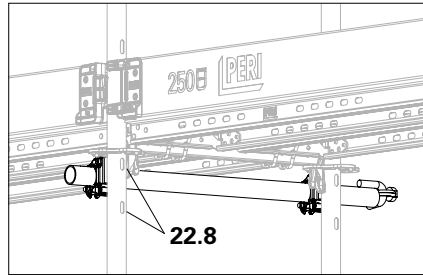

Fig. A7.04

Right or left on the frame column.

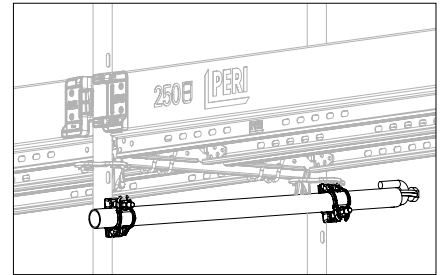

Fig. A7.04a

Vertically inclined. Attention: reduced clearance height!

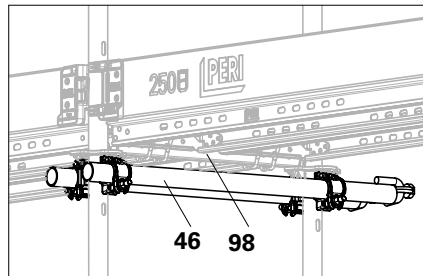

Fig. A7.04b

On both sides of the frame column.

General

Polycover components are optional, and not required in the standard configuration

All polycover - components

- make use of signal colours to indicate hazard areas,
- lower the risk of injury in the event of impact,
- reduce fouling.



Note

If handled incorrectly, polycover components may break.

- ⇒ Do not use a hammer when working with polycover components.
- ⇒ In temperatures below 0 °C, warm up polycover components prior to assembly.

Poly Cover Tube UPC-T

For closing tube ends with $d = 48.3 \text{ mm}$. (Fig. A8.01)



Fig. A8.01

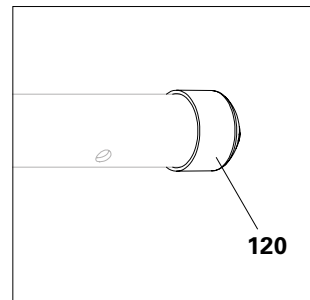

Fig. A8.02

1. Push the Poly Cover Tube UPC-T (**120**) onto the end of a tube with $d = 48.3 \text{ mm}$. (Fig. A8.02)
- The poly cover is mounted.

Poly Cover Rosette UPC-R

For protection around ledger-free rosettes. (Fig. A8.03)

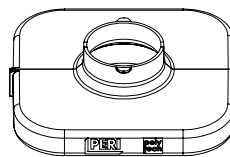

Fig. A8.03

1. Position the Poly Cover Rosette UPC-R (**121**) with one half on the rosette.
 2. Close the second half.
 - The clip fastener engages.
 - The poly cover is mounted.
- (Fig. A8.04)

- The poly cover rosette can be additionally secured with cable ties.

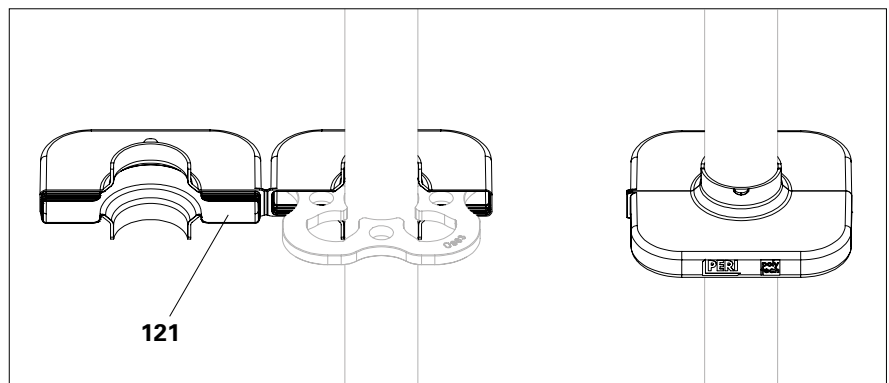

Fig. A8.04

Poly Cover Coupling UPC-C

For protection around a rosette with mounted ledgers or around bolted tube/coupler connections.
(Fig. A8.05 - A8.07a)

Assembly

1. Clip the Poly Cover Couplings UPC-C (**122**) onto the scaffold standard $d = 48.3 \text{ mm}$.
 2. For ledgers arranged around a 90° corner: fit Poly Cover UPC-C (**122 + 122a**) in an overlapping manner. (Fig. A8.06)
 3. If ledgers are arranged longitudinally: fit Poly Cover UPC-C on both sides. (Fig. A8.06a)
 4. In case of crossing tubes, mount 2x poly covers UPC-C overlapping on one or both tubes. (Fig. A8.07 + A8.07a)
- The poly cover is mounted.



Use cable ties to provide the poly cover couplings with extra reinforcement.

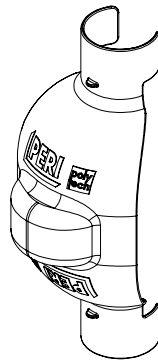

Fig. A8.05

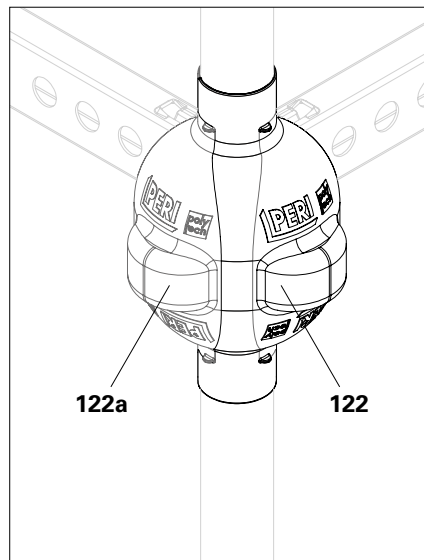

Fig. A8.06

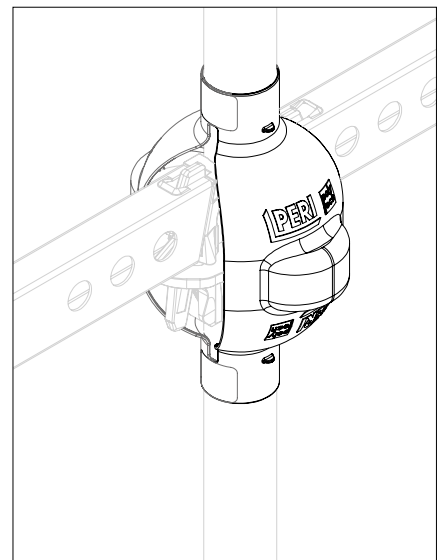

Fig. A8.06a

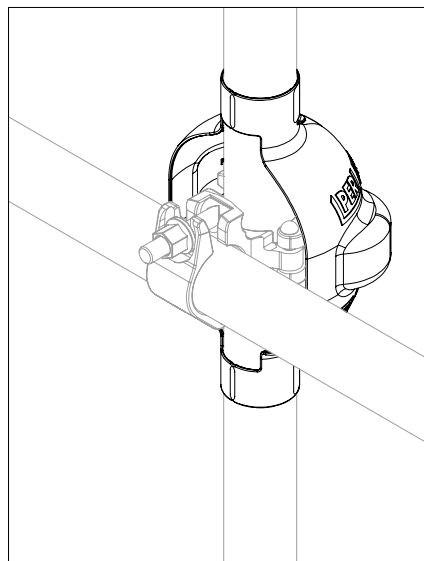

Fig. A8.07

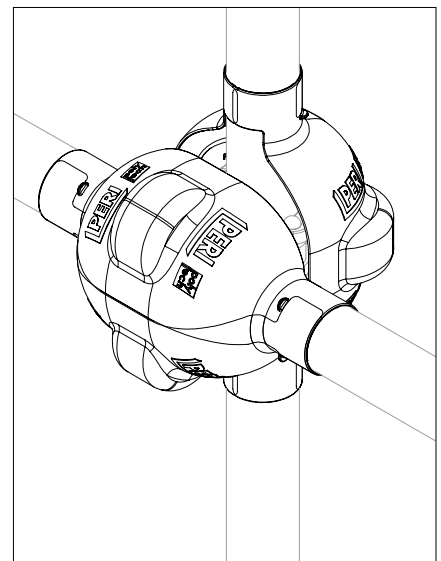

Fig. A8.07a

Spindle Lining UES

Spindle Lining UES serves to protect the substrate.

If additional reflectors (**123.1**) are installed, this improves visibility.
(Fig. A8.08)

The component can transfer compression forces of up to 50 kN.

Assembly

1. Place the spindle lining (**123**) on a flat and load-bearing substrate
2. Position the spindle centrally
→ The spindle lining is installed.
(Fig. A8.08a)

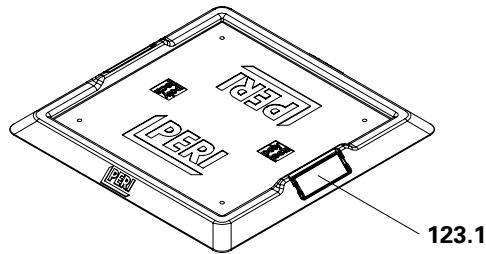

Fig. A8.08



Static proof for transferring forces into the substrate is to be carried out separately.

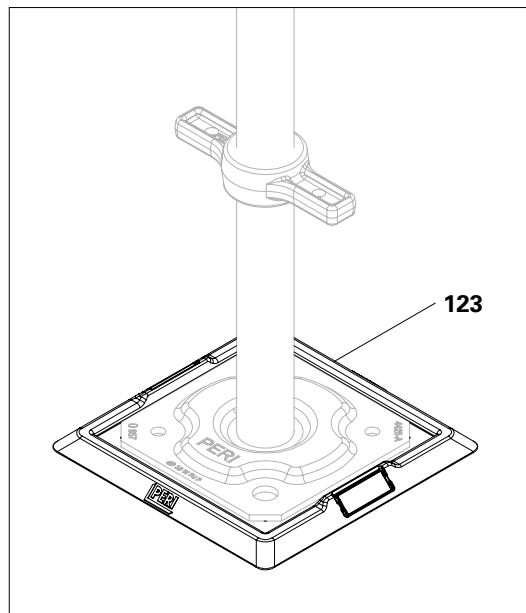

Fig. A8.08a

General

Note

Stability compromised!

- ⇒ Settlements must be avoided! The scaffold may only be erected on sufficiently load-bearing substrate with load-distributing pads. For the support forces, see Section "F2" or "G2 Support forces".
- ⇒ Observe the maximum spindle extension! Use the permitted maximum extension length in the tie patterns for each load class and equipment variation.

Changes in height and inclined erection surfaces

Base Compensation EVA

On sloping ground or in the event of changes in height, adjust the scaffold using Base Compensation EVA 50 (13) or EVA 100 (14) to accommodate the terrain (see Fig. B1.02, next page).

By combining two different Base Compensations EVA (13/14) and two different Base Spindles UJB (10/11), differences in height of 0 – 2.00 m can be accounted for without any gaps. (Fig. B1.01)

The smallest possible dimension from the contact area to the surface of the base layer H_{min} is 25 cm.

Alternatively, height jumps can be realised with Standards UVR and Base Standards UVB.

For combinations, see Tables.

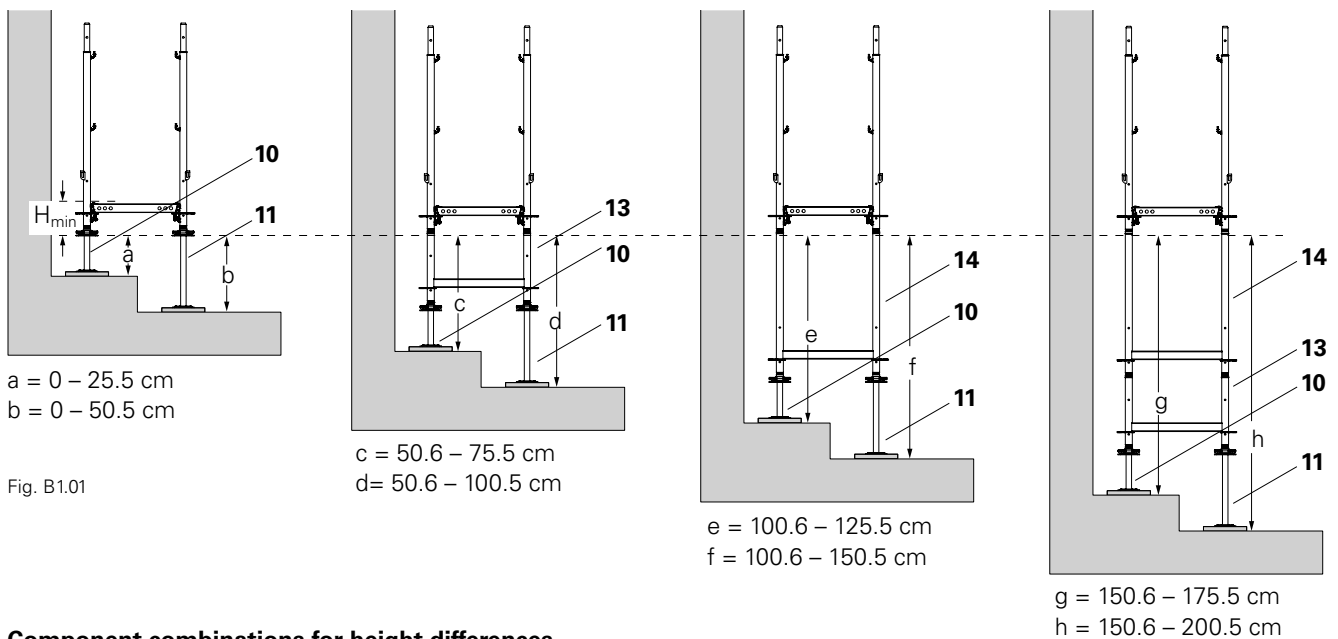

Component combinations for height differences

Fig.	Height difference	Base Spindle UJB 38-50/30 (10) (red nut)	Base Spindle UJB 38-80/55 (11) (yellow nut)	Base Compensation EVA 50 (13)	Base Compensation EVA 100 (14)
a	0 – 25.5 cm	X			
b	0 – 50.5 cm		X		
c	50.6 – 75.5 cm	X		X	
d	50.6 – 100.5 cm		X	X	
e	100.6 – 125.5 cm	X			X
f	100.6 – 150.5 cm		X		X
g	150.6 – 175.5 cm	X		X	X
h	150.6 – 200.5 cm		X	X	X

Additional bracing

Base compensations require additional longitudinal bracing

- if there are no diagonals within the next 5 bays
- or if the diagonal is not directly connected to decking or horizontal ledgers.

Examples

- A Base compensation with Ledger Brace UBL (99) and Horizontal Ledger UH-2 (94) connected to diagonal.
- B Diagonal extended into the base compensation with Ledger Brace UBL (99) and horizontal ledgers.
- C Base compensations are connected directly to braced bay within 5 bays.
- D Base compensations connected to start of scaffolding with Face Brace EBF (20) and Horizontal Ledger UH-2 (94) connected to diagonal.



- For the permitted maximum extension length for each load class and equipment combination, refer to the tie patterns in the Section Tie pattern.
- Separate static proof is required for other cases

Example A

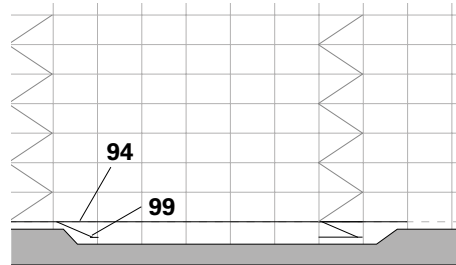

Example B

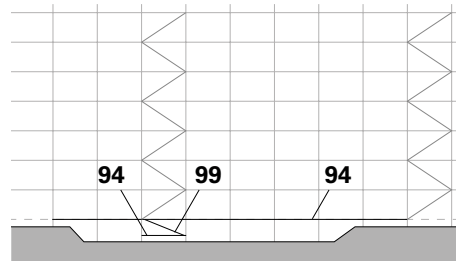

Example C

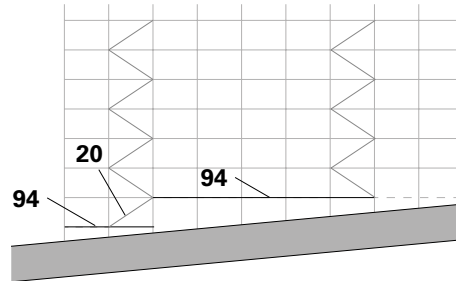

Example D

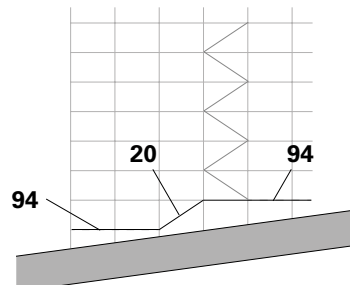

Fig. B1.02

Assembly

1. Fit Horizontal Ledgers UH-2 (**94**) into the rosettes of the Base Standards EVS.
2. Mount Support UC 33 (**61**) on the $\frac{3}{4}$ rosettes of the Base Compensation EVA (**13/14**). Secure the wedges. (Fig. B1.03)
3. Mount Ledger Brace UBL-2 (**99**): insert mounting ring (**99.1**) into the horizontal ledger. Place the gravity pin (**99.2**) in an upright position and push through the Support UC 33 (**61**). Tilt the gravity pin on the inner side.

→ Additional bracing is installed (Fig. B1.04 – B1.05a)

Components

10	Base Spindle UJB 38-50/30
11	Base Spindle UJB 38-80/55
13	Base Compensation EVA 67/50
14	Base Compensation EVA 67/100
61	Base Standard EVS 124
94	Support UC 33
99	Horizontal Ledger UH-2
	Ledger Brace UBL-2

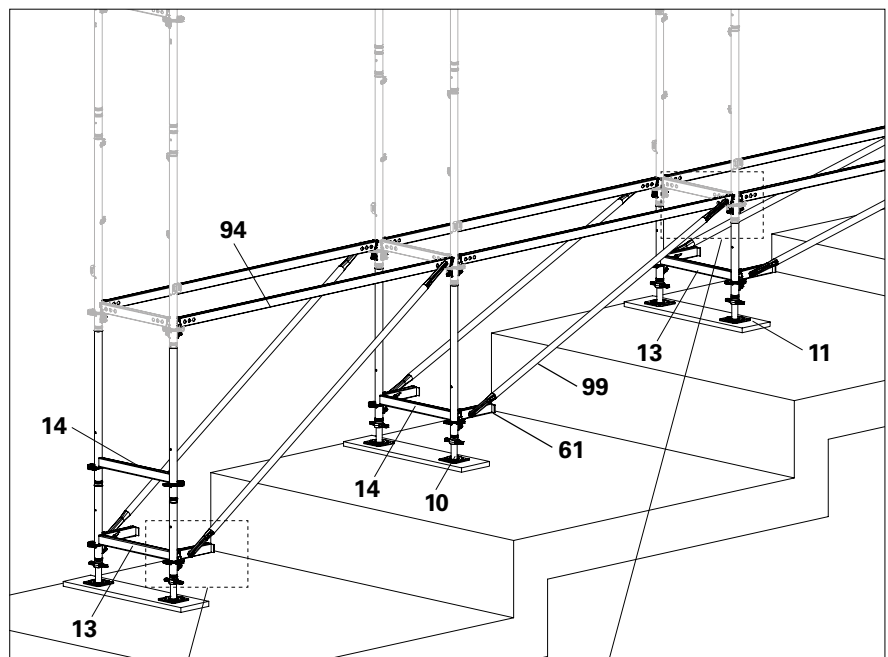

Fig. B1.03

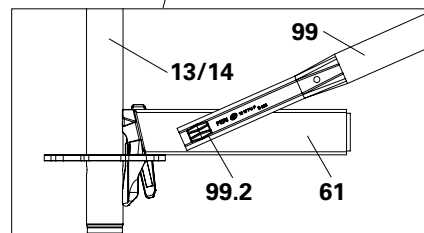

Fig. B1.04

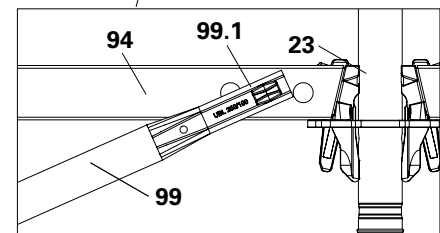

Fig. B1.05

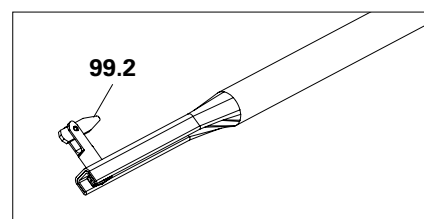

Fig. B1.04a

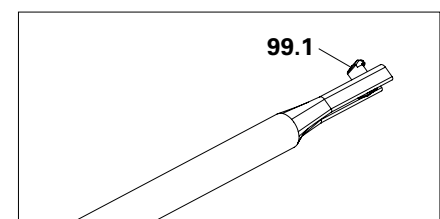

Fig. B1.05a



- Alternatively, the Supports UC 25 can also be used instead of Support UC 33 (**61**).
- Alternatively, if the compensation height is 1.0 m or 1.5 m, Node Braces UBK can also be used.
- If space is limited, use the Ledger Brace UBL-2.
- Alternatively, first mount the ledger brace on the horizontal ledger (**94**), then install together on the base frame (**15**).

General

Assembly of the scaffold must follow the sequence described below!

Load-distributing supports



Use load-distributing supports subject to the load-bearing capacity of the substrate.

- Supports and ground plates must make full-face contact with the substrate.

Assembly

Start assembling at the highest point of the ground (= the least height compensation), see Section "B1 Substructure" on page 50 ff.

1. Set out Horizontal Ledgers UH-2 (**94**) in the longitudinal direction.
2. If necessary, set out load-distributing supports.
3. Set out Horizontal Ledgers UH-2 (**98**) in the transverse direction.
4. Set up the Base Spindles UJB (**10**). (Fig. B2.01)

Components

-
- | | |
|-----------|----------------------------|
| 10 | Base Spindle UJB 38-50/30 |
| 23 | Base Standard EVS 124 |
| 30 | Steel Deck EDS |
| 94 | Horizontal Ledger UH-2 300 |
| 98 | Horizontal Ledger UH-2 67 |
-

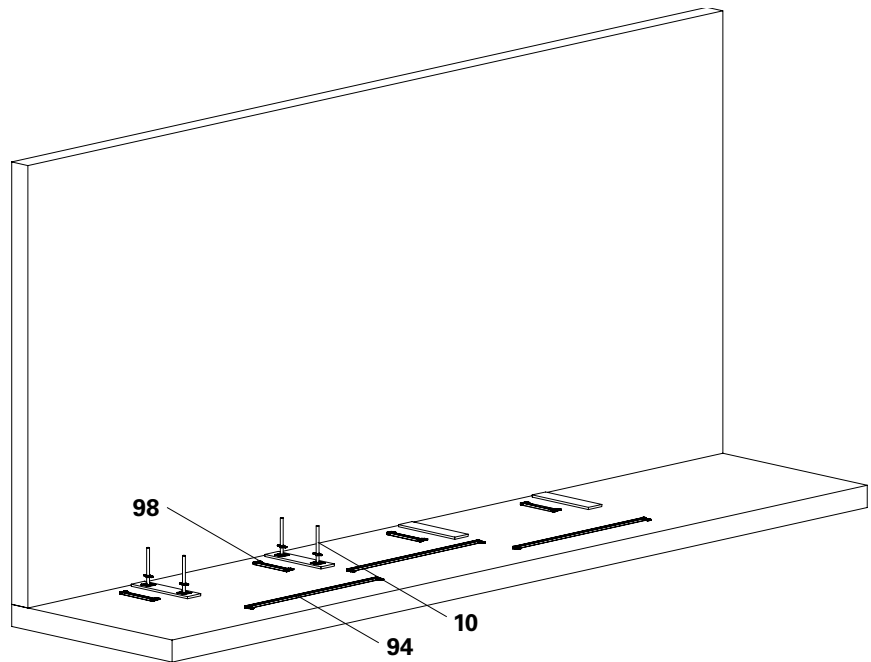

Fig. B2.01

Base unit



- PERI recommends starting the assembly process in a diagonal bay.
- Each diagonal bay is braced using Horizontal Ledgers UH-2, see Section Tie pattern.
- Hammer in wedges of the Horizontal Ledgers UH-2 only after alignment has taken place!

Assembly

1. 2 x Easy Base Standard EVS 124 (**23**) and Fit 1 x Horizontal Ledger UH-2 67 (**98**) onto a base unit. (Fig. B2.02)
 2. Secure with Horizontal Ledger UH-2 (**94**) to prevent it from falling over. (Fig. B2.02)
 3. Fit the second base unit and connect with Horizontal Ledger UH-2 (**94**).
 4. The base level is aligned horizontally by accurately adjusting the Base Spindles UJB (**10**). Adjust the distance to the structure. (Fig. B2.03a)
 5. Securely fix the wedges of the Horizontal Ledger UH-2 (**94**) in position with a jarring blow using a hammer.
- The base unit is installed. (Fig. B2.03)



PERI recommends using horizontal ledgers as an assembly aid. From a static point of view, horizontal ledgers are not always required, see the Section Tie pattern.

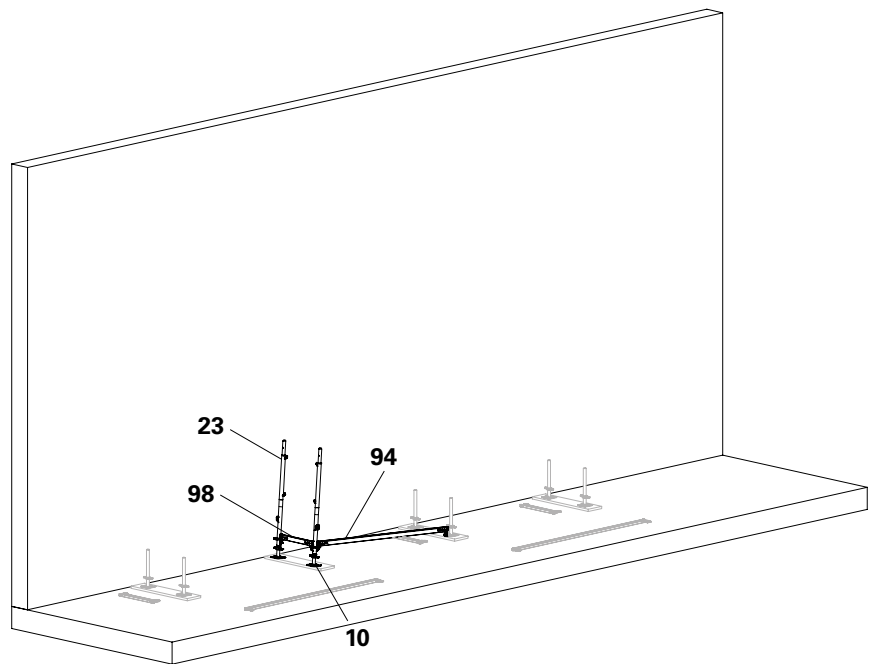

Fig. B2.02

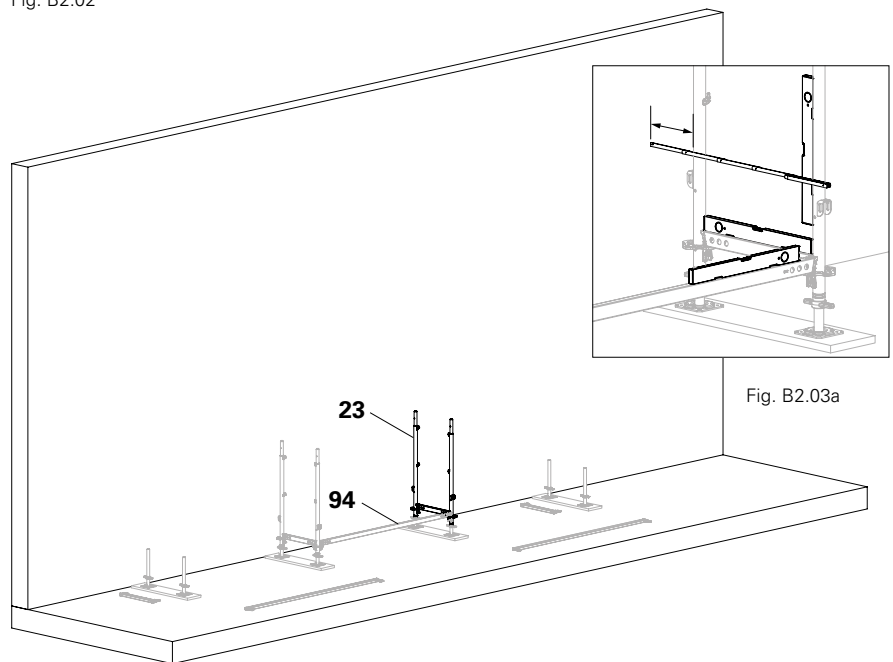

Fig. B2.03

Assembly aid for the decking

Hook the Steel Deck EDS (30) into the base unit as an assembly aid.

Assembly

1. Pick up the deck (30) from the centre and place it on the Horizontal Ledgers UH-2 (98).

→ The deck is now installed.

(Fig. B2.04)



Have both lift locks (30.1) dropped below the horizontal ledger?
If not, lift the deck slightly and let it drop into position or operate the lift lock manually.
(Fig. B2.04a)



The Steel Decks EDS (30) used at the base are assembly aids only. They can be removed later. This does not apply to bays where access decks are fitted.

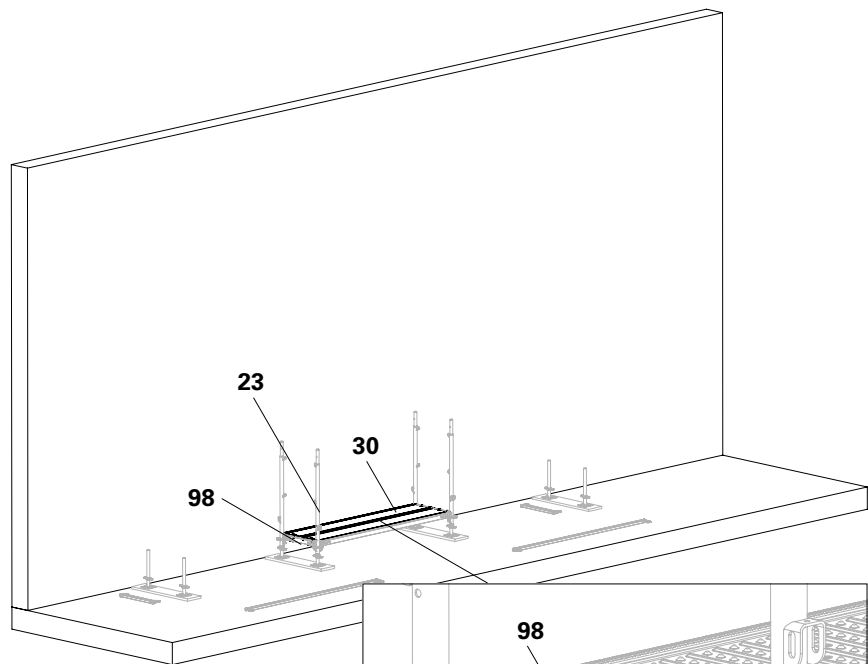

Fig. B2.04

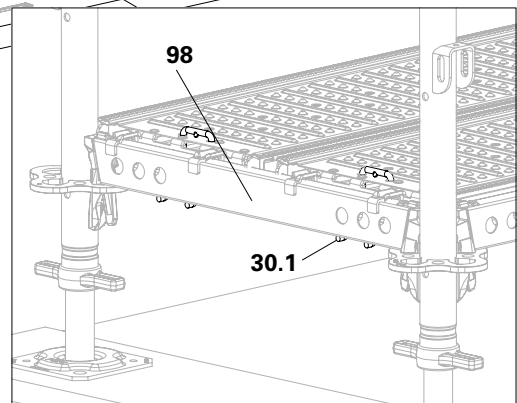

Fig. B2.04a

Easy standards and guardrail post

The Guardrail Post EPG (**51**) is continuously mounted together with the Easy Standard (**22**) from a secure position in the next scaffolding bay.

Assembly

1. Position 2 x Easy Standard EVM 200 (**22**) on the Easy Base Standards EVS 124 (**23**). Turn the guardrail connections (**22.1**) to the deck side.
2. Fit Horizontal Ledger UH-2 67 between the Easy standards (**98**). Secure the wedges. (Fig. B2.05)
3. Attach Guardrail Post EPG (**51**) to the upper guardrail hooks (**22.1**) of the attached Easy Standard EVM, see "A3 System components: Lateral protection" on page 24. (Fig. B2.06 + B2.06a)



Turn the guardrail hooks of the inner Easy Standard EVM (**22a**) towards the wall if no inner guardrails are required. This enlarges the clear passage width.

Components

- | | |
|-----------|---------------------------|
| 20 | Face Brace EBF |
| 22 | Easy Standard EVM 200 |
| 23 | Base Standard EVS 124 |
| 30 | Steel Deck EDS |
| 51 | Guardrail Post EPG |
| 98 | Horizontal Ledger UH-2 67 |

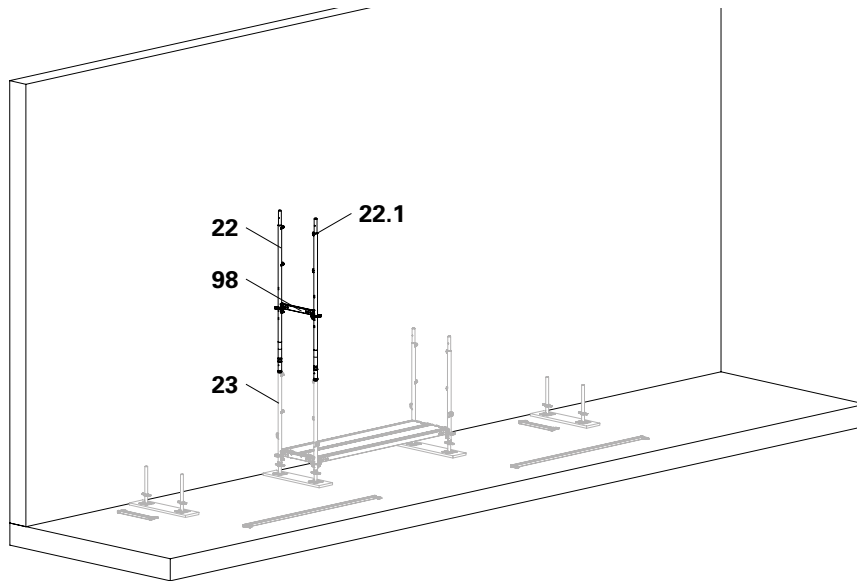

Fig. B2.05

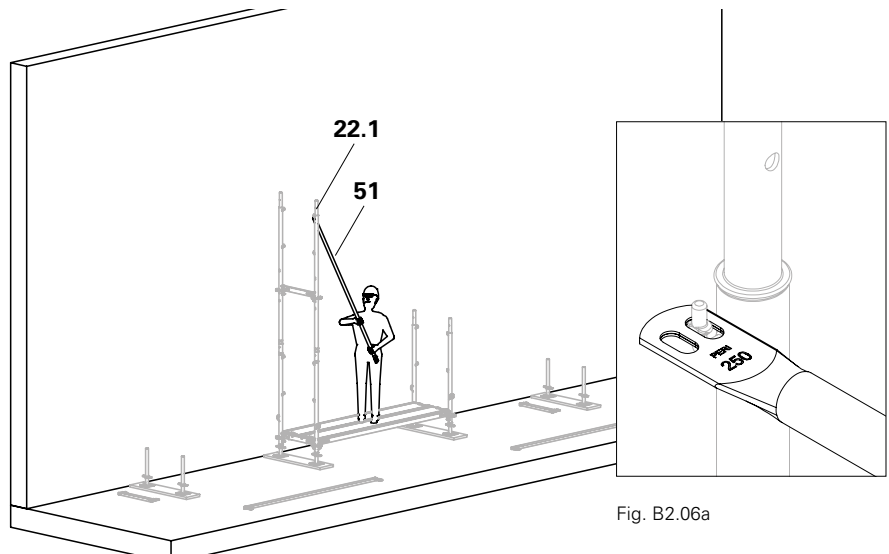

Fig. B2.06a

Fig. B2.06

B2 First scaffold bay

3. Attach Guardrail Post EPG (**51**) to the guardrail hooks (**22.1**) of the second Easy Standard EVM.

(Fig. B2.07)



Assembly of the Easy Standard EVM can also be carried out in a “double-advanced” manner with guardrails and intermediate guardrails. See Section “A3 System components: Lateral protection” on page 24.

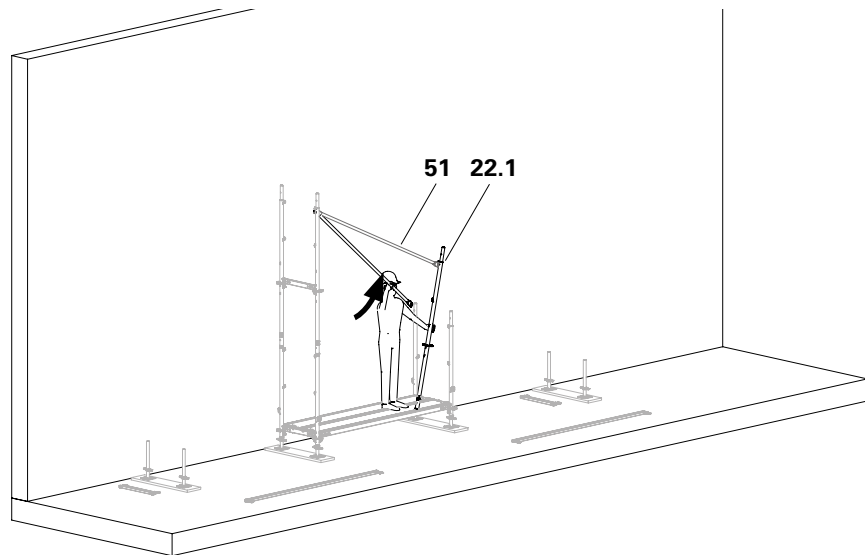

Fig. B2.07

4. Position the second Easy Standard EVM (**22**) together with Guardrail EPG (**51**) on the available Base Standard EVS (**23**).
 5. Mount another Easy Standard EVM (**22a**) on the inner side of the scaffold.
 6. Connect both Easy standards with Horizontal Ledger UH-2 67 (**98**).
- Easy standards and the guardrail post are installed.

(Fig. B2.08)



In the material acceptance bay, install the guardrail and intermediate guardrail in advance.

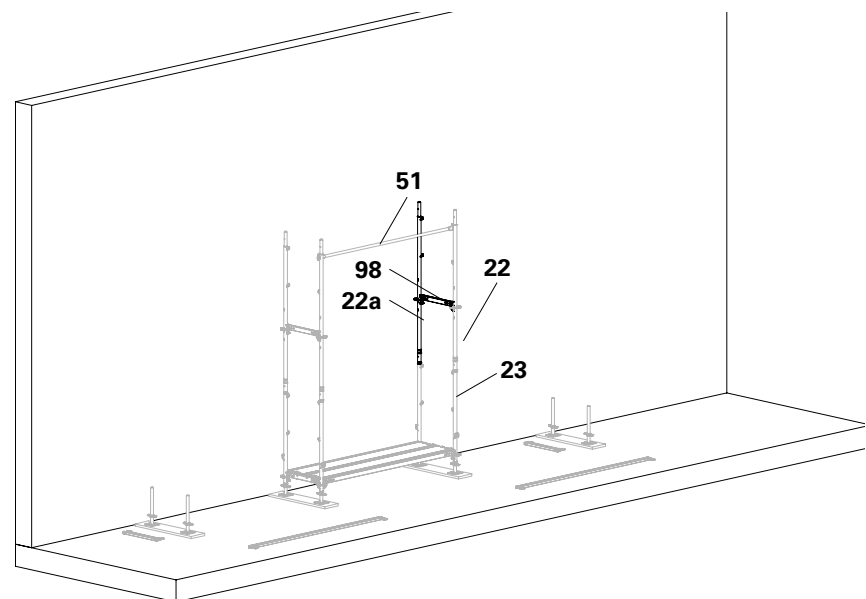

Fig. B2.08

Decks

Note

Stability compromised without system decking.

⇒ System decks are bracing components and must, therefore, be installed across the full scaffolding width and in every scaffold bay!

Assembly

1. To install the decks, see "A4 System components: Deck" on page 34.
→ The deck is now installed. (Fig. B2.09)



Horizontal Ledgers UH-2 are generally not required on deck levels. However, some additional fittings require horizontal ledgers in certain positions. See Section Tie pattern.

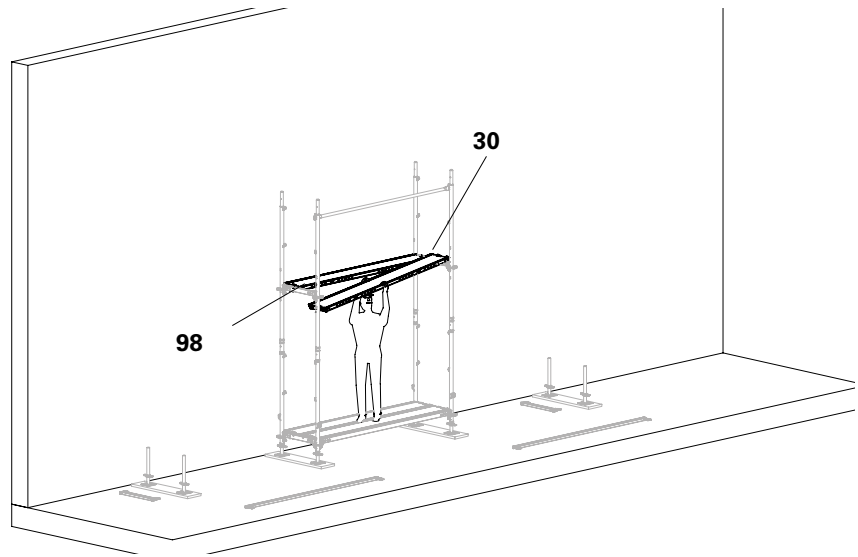

Fig. B2.09

Face braces

Note

Stability compromised due to missing face braces or horizontal ledgers.

⇒ Comply with the tie pattern!

Assembly

1. To install the Face Brace EBF (20), see Section "A5 System component: Diagonal Bracing" on page 38.
→ The face brace is now installed.
2. Fit the horizontal ledgers according to the tie pattern. (Fig. B2.10)

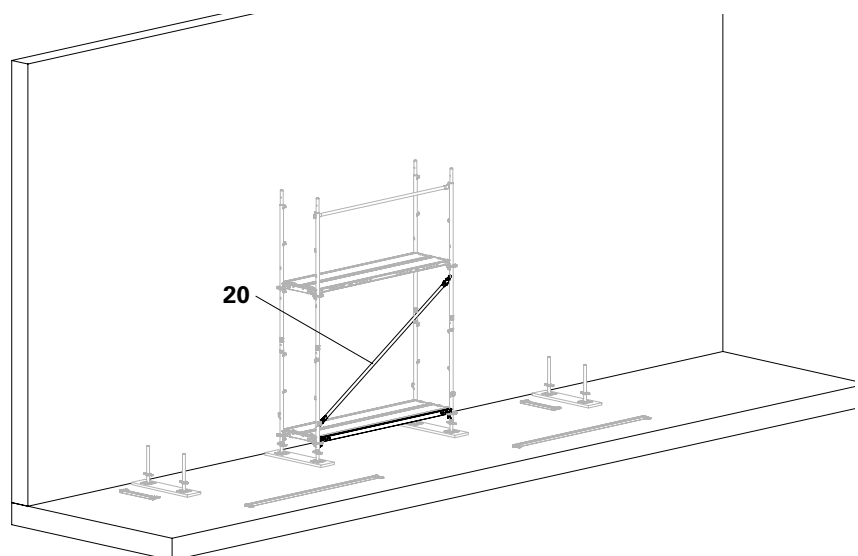

Fig. B2.10

Other scaffold bays

Assembly of other scaffold bays takes place in both directions starting from the scaffold bay with diagonals.
(Fig. B3.01)

Assembly

1. Insert additional Base Standards EVS (23) into Base Spindles UJB and connect with horizontal ledgers (98).
 2. Connect to existing scaffold bay with horizontal ledger (94) and align.
 3. Position decks (30) as assembly aids.
- ➔ If the base level is to be used as a working area, PERI recommends covering the entire level with decking.

(Fig. B3.01)

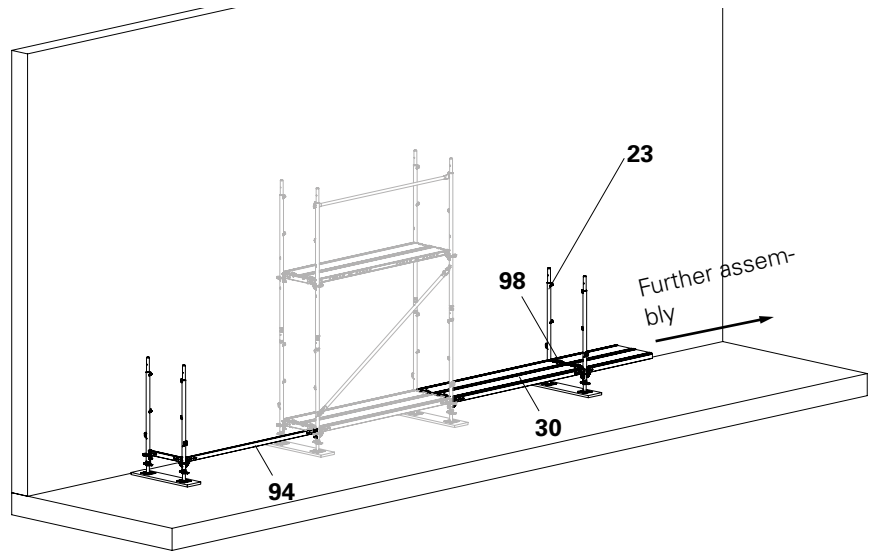

Fig. B3.01

4. Install Guardrail Post EPG (51) in the existing scaffold bay and insert together with the Easy Standard EVM (22).
5. Insert Easy standards (22a) on the inner side of the scaffold.
6. Connect Easy Standards EVM (22 + 22a) with horizontal ledgers (94). Secure the wedges.
7. Install End Guardrail in Advance UPA 67 (52) in the edge bay, see Section "End Guardrail UPA in advance" on page 29. (Fig. B3.02)

Alternatively:

Fit End Guardrail EPF, see Section "End Guardrail in Advance EPF" on page 32. (Fig. B3.02a)

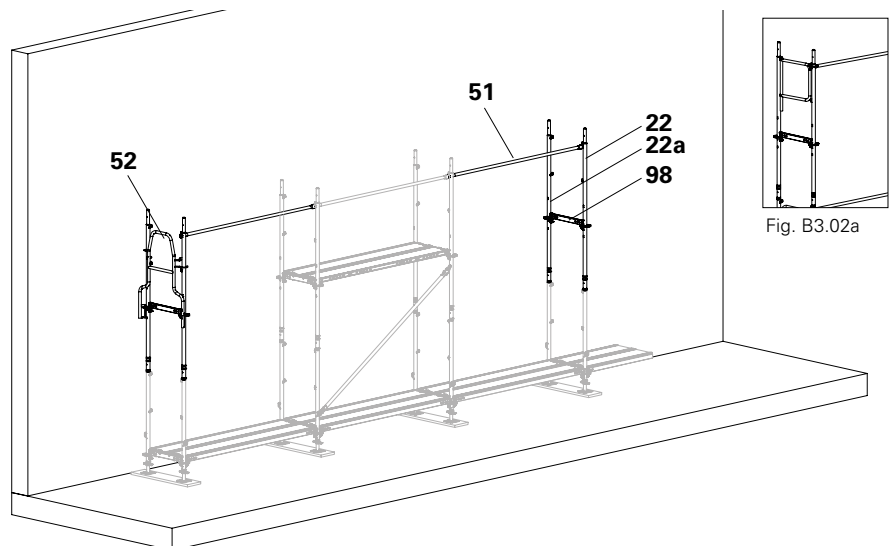

Fig. B3.02a

Fig. B3.02

6. Install decks (30) in the first scaffold level.
 7. Install Access Decks EAW-L (40), see "Internal access with access deck" on page 90.
- Other scaffold bays have been installed.
(Fig. B3.03)



After these work steps, the decks (30a) and horizontal ledgers (94) can be removed from the base level and used elsewhere. (Except in the access bay or if statically required)

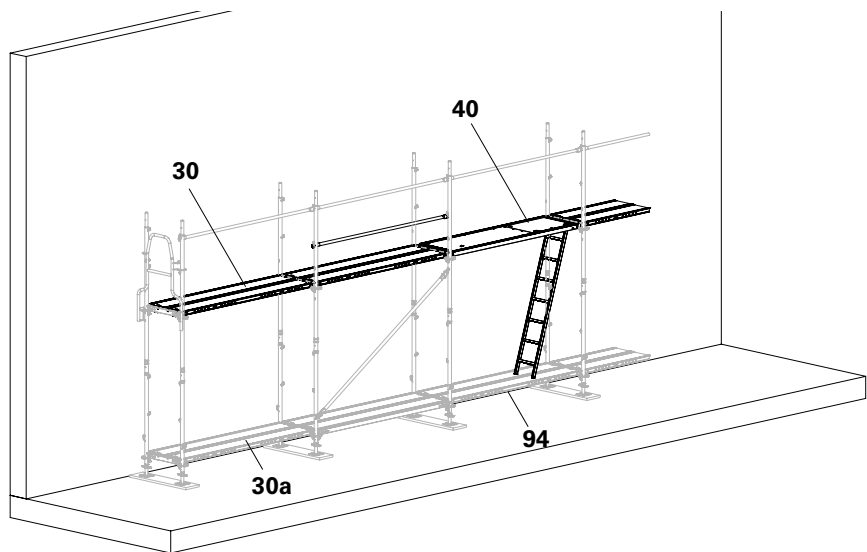

Fig. B3.03

Lateral protection

Ensure that lateral protection is complete in every scaffold bay.

Intermediate guardrail

Assembly

If not already mounted as "double advanced" guardrails:

1. Attach Guardrail EPG (51a) as an intermediate guardrail post on both sides, one after the other, on the guardrail hooks, see Section "A3 System components: Lateral protection" on page 24.

→ The intermediate guardrail is now mounted.

(Fig. B3.04)

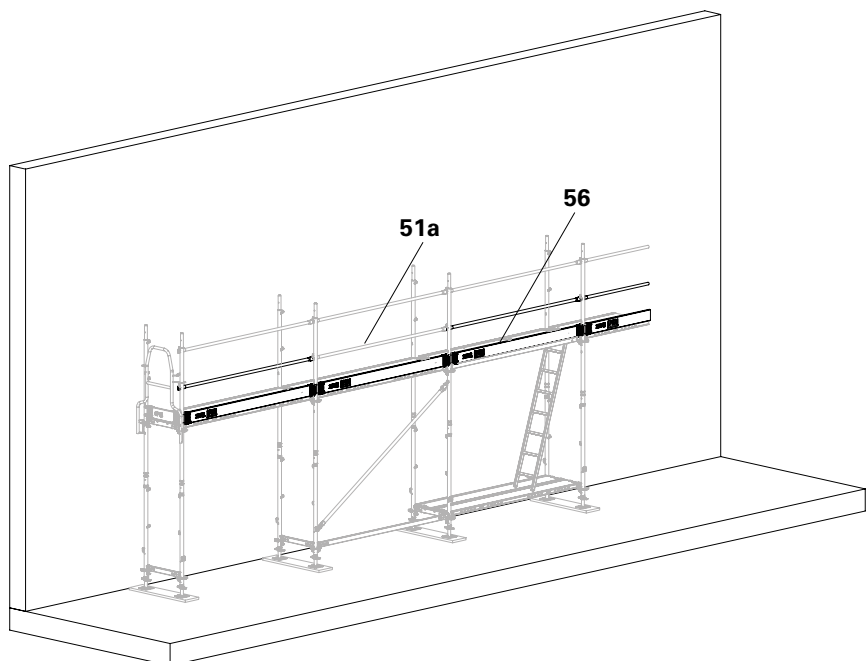

Fig. B3.04

Toe board

Assembly

1. Fit Toe Board UPF (56) on both sides, one after the other onto the standards, see Section "A3 System components: Lateral protection" on page 24.

→ The toe board is now installed.

(Fig. B3.04)



Toe Board UPY (**57**) can be installed instead of Toe Board UPF, see Section "A3 System components: Lateral protection" on page 24 ff. (Fig. B3.05)

Components

- 22** Easy Standard EVM 200
- 23** Base Standard EVS 124
- 30** Steel Deck EDS
- 40** Access Deck EAW-L
- 51** Guardrail Post EPG
- 52** Advance End Guardrail UPA 67
- 56** Toe Board UPF
- 57** Toe Board UPY
- 94** Horizontal Ledger UH-2 300
- 98** Horizontal Ledger UH-2 67



Install intermediate guardrails in the assembly sequence of the scaffolding.

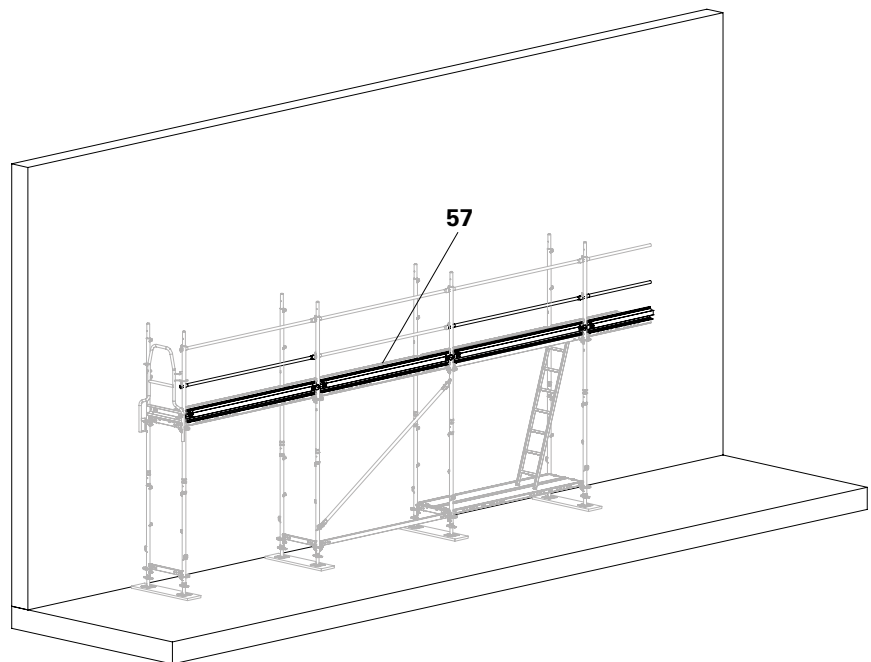

Fig. B3.05

Other levels

Assembly

1. Insert Easy Standards EVM (**22a**) into all inner standards.
2. Fit Easy Standards EVM (**22**) with Guardrail in Advance EPG (**51**) onto all outer legs.
3. Connect Easy standards with horizontal ledgers (**98**). Secure the wedges. (Fig. B4.01)



Turn the guardrail hooks of the inner Easy Standard EVM (**22a**) towards the wall if no inner guardrails are required. This enlarges the clear passage width.

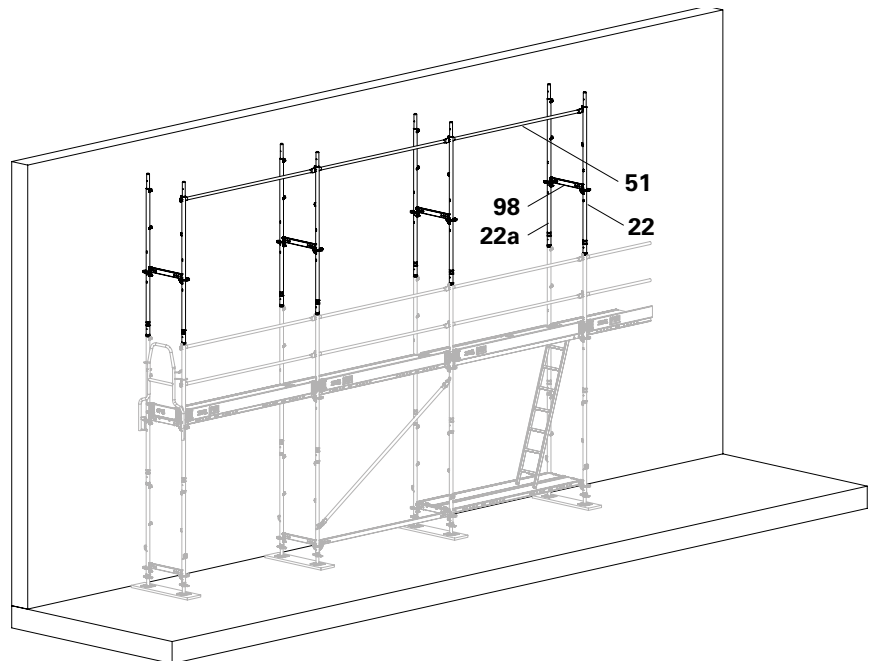

Fig. B4.01

4. Attach End Guardrail in Advance UPA 67 (**52**) to the front side.
5. Install decking (**30**). (Fig. B4.02)

Components

20	Face Brace EBF
22	Easy Standard EVM 200
30	Steel Deck EDS
46	Wall Tie UWT
50	Guardrail Post EVP
51	Guardrail Post EPG
52	Advance End Guardrail UPA 67
56	Toe Board UPF
98	Horizontal Ledger UH-2 67

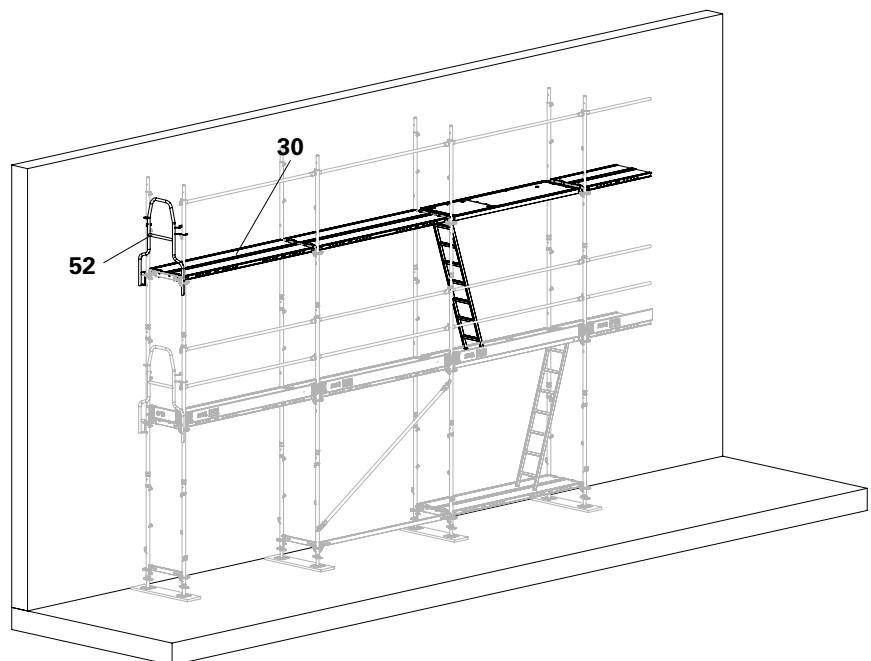

Fig. B4.02

6. Fit Face Braces EBF (20) in accordance with the Section Tie pattern. (Fig. B4.03)



Always fit the face braces after the decks. This simplifies the deck installation process.

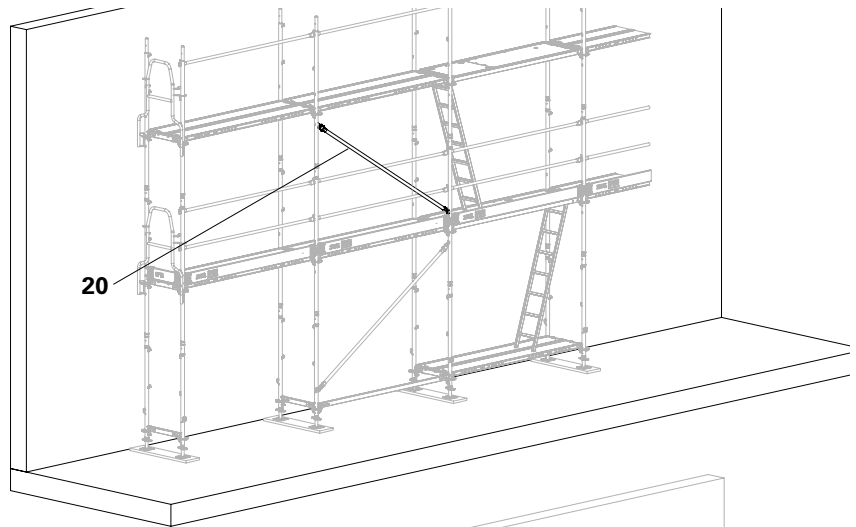

Fig. B4.03

7. Install intermediate guardrail (51a) and Toe Board UPF (56). → The next level is now installed. (Fig. B4.04)



Repeat assembly steps 1 to 7 until all scaffold levels are complete.

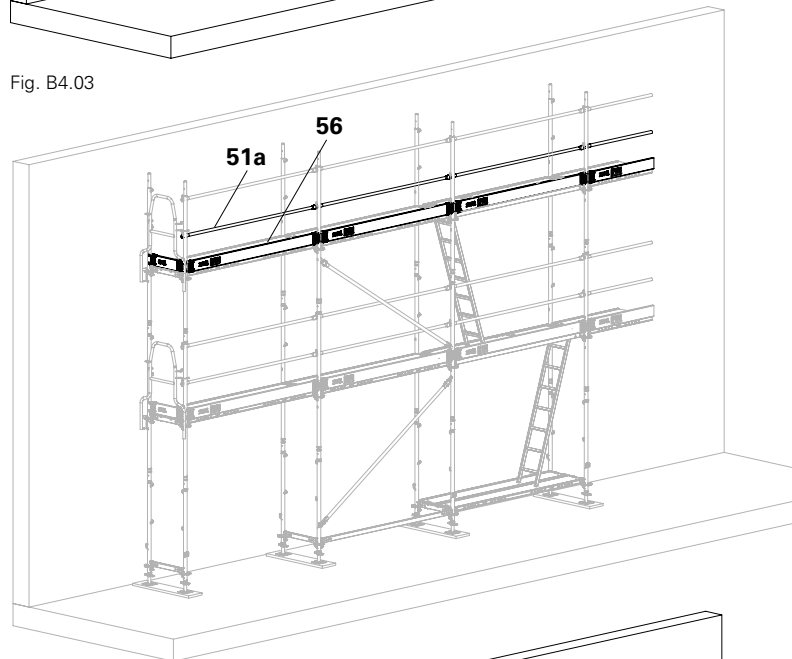

Fig. B4.04

Anchoring

Fit Wall Ties UWT (46) continuously in line with the scaffold assembly. (Fig. B4.05 + B4.05a)



- For information on assembling the anchoring, see Section "A7 System component: Wall tie coupler" on page 44.
- Refer to Section "Tie pattern" for the number and position of the ties.

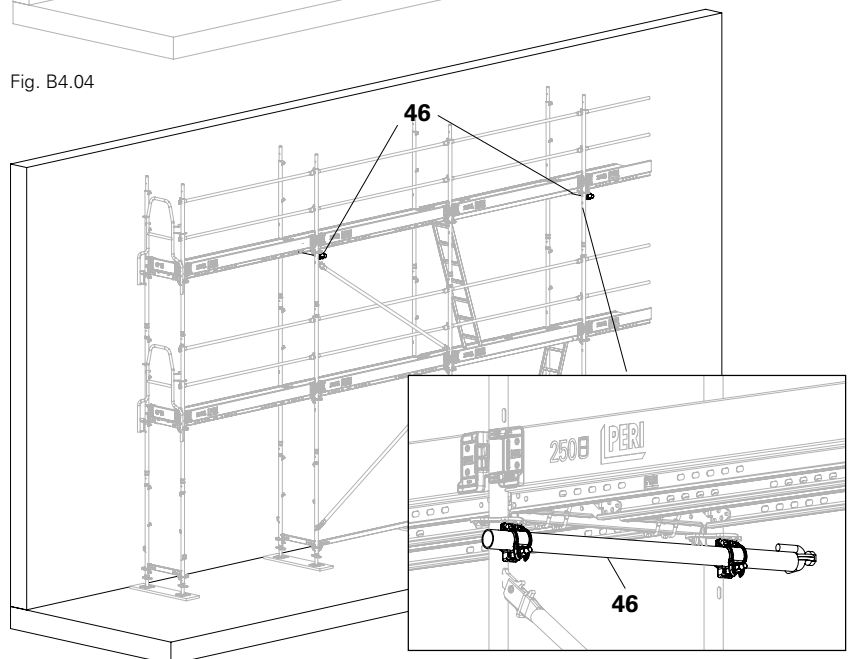

Fig. B4.05

Fig. B4.05a

Disassembly



- Follow the dismantling sequence!
- Before dismantling the scaffolding, check that all guardrail posts are mounted in the same direction on the guardrail hooks in a "fish scale arrangement". See Section "B9 Scaffold modification" on page 92.
- Have any dismantled components taken away from the scaffold immediately; do not store them somewhere temporarily.

Dismantling

1. Dismantle the Toe Boards UPF (56) and intermediate guardrails (51a). The top Guardrail Posts EPG (51) remain in position as anti-fall protection.

(Fig. B5.01)



The intermediate guardrail post can also be dismantled together with the guardrail (step 3).

2. From the level immediately below, remove the Wall Tie UWT (46), decks (30), Face Brace EBF and End Guardrail in Advance UPA (52).

(Fig. B5.02)

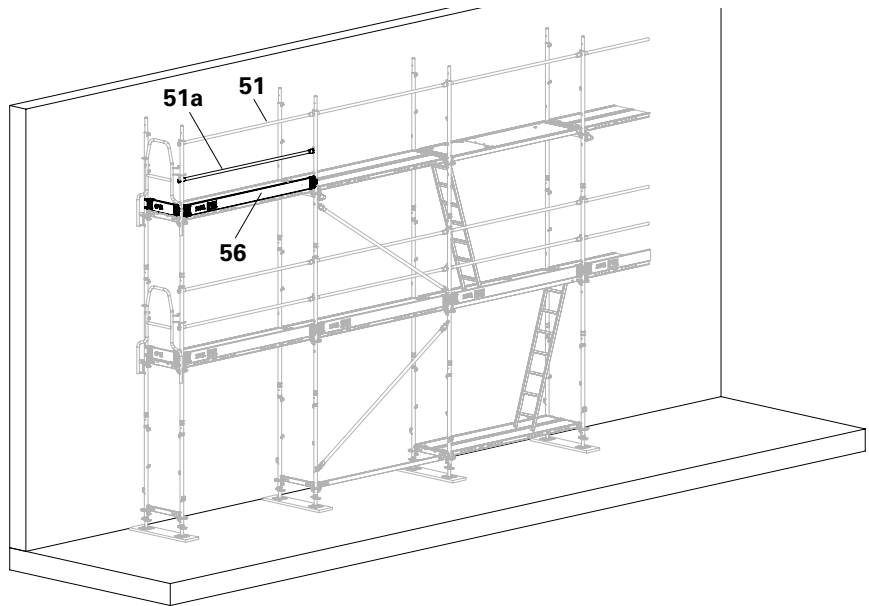

Fig. B5.01

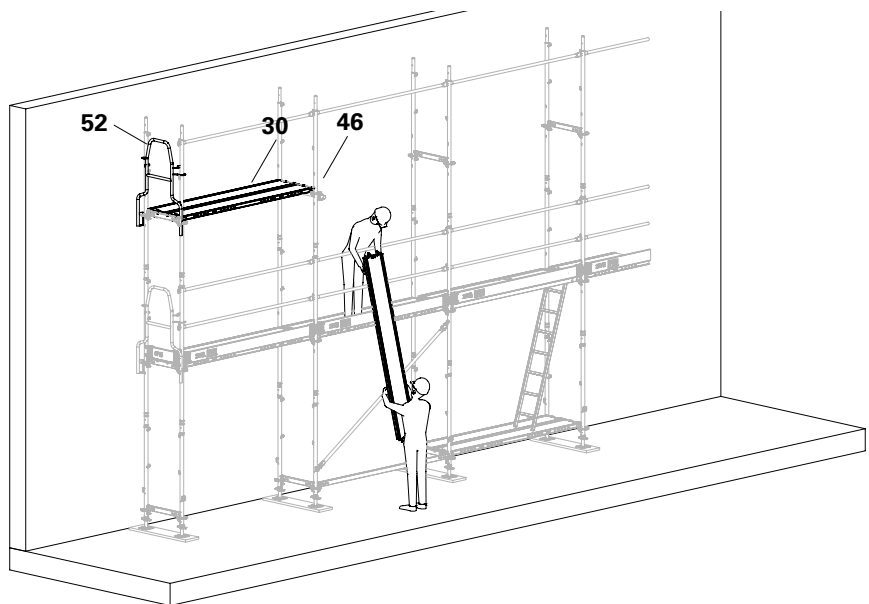

Fig. B5.02

3. Remove the Horizontal Ledger UH-2 67.
 4. Remove the Easy Standards EVM (22) together with the top Guardrail Post EPG (51) in the reverse order of the assembly sequence. Otherwise the guardrail posts cannot be unhooked.
- (Fig. B5.03)

Repeat steps 1 – 4 until the entire scaffold has been dismantled.

! **Note**

Do not drop the guardrail post. This will prevent any possible damage to the guardrail post or decks.
⇒ Guide the guardrail post manually.



To dismantle the last scaffold level, install auxiliary decks at the base level.

Components

- 20 Face Brace EBF
- 22 Easy Standard EVM 200
- 30 Steel Deck EDS
- 46 Wall Tie UWT
- 51 Guardrail Post EPG
- 52 Advance End Guardrail UPA 67
- 56 Toe Board UPF
- 98 Horizontal Ledger UH-2 67

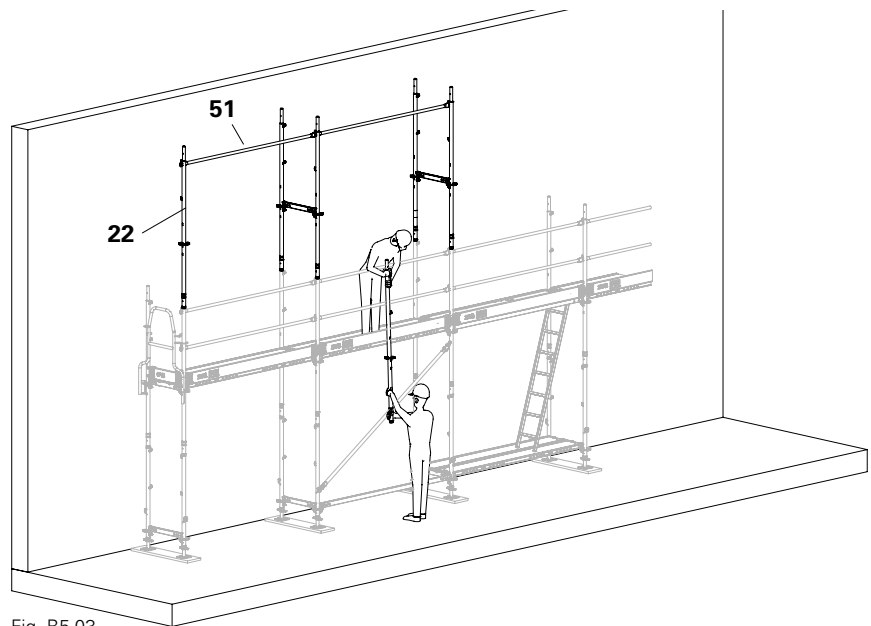

Fig. B5.03

General

- Start the assembly process at the corner.
- Position decks in the base level as assembly aids.

Outside corner

In this version of the assembly process, the decks on the base level are taken out again. (Fig. B6.01a)

Assembly of a continuous scaffold bay

1. Set up the base units.
2. Fit two Horizontal Ledgers UH-2 (94a) into the continuous scaffold bay (A). Secure the wedges.
3. Connect the adjacent scaffold bay (B) with one horizontal ledger (94).
4. In both of the following bays, fit two Horizontal Ledgers UH-2 (94b) (one diagonal is installed in each of these bays). (Fig. B6.01a)
5. Connect two Easy Standards EVM (22) with Horizontal Ledger UH-2 67 (98). The guardrail hook (22.1) on the Easy standard (22) points inwards in the direction of the continuous scaffolding.
6. Attach the guardrail post (51). (Fig. B6.01)

Components

20	Face Brace EBF
22	Easy Standard EVM 200
23	Base Standard EVS 124
30	Steel Deck EDS
51	Guardrail Post EPG
52	Advance End Guardrail UPA 67
94	Horizontal Ledger UH-2 300
98	Horizontal Ledger UH-2 67

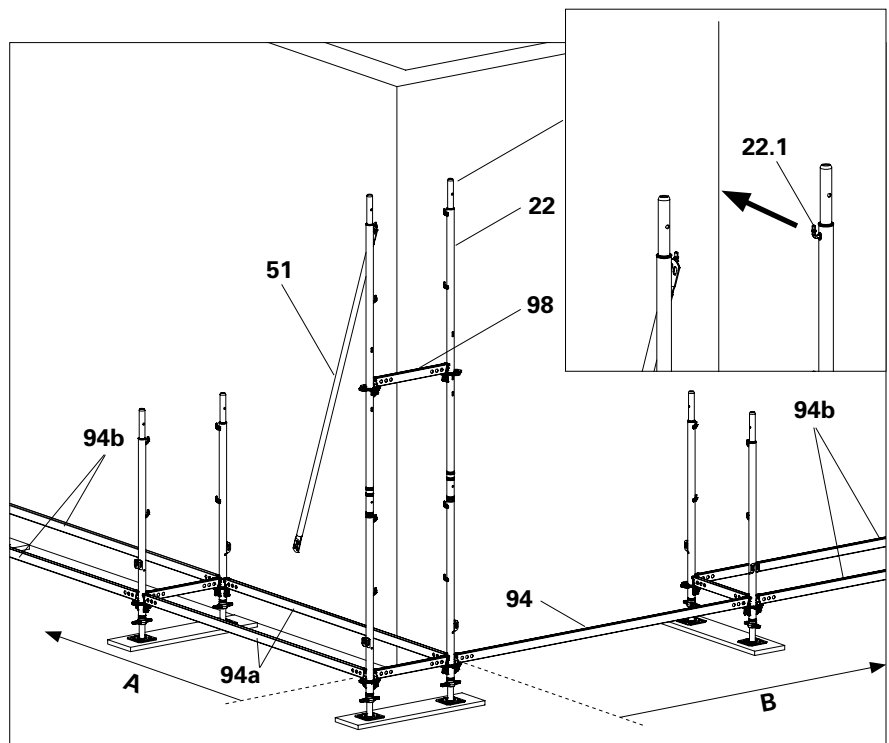

Fig. B6.01

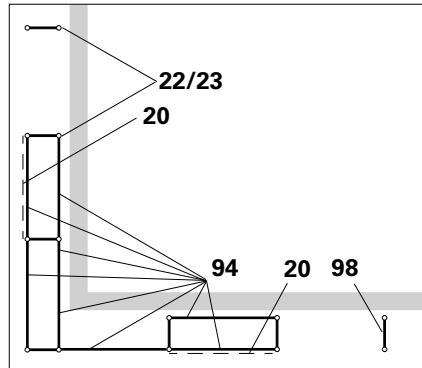

Fig. B6.01a

Arrangement of the Horizontal Ledgers UH-2 (94) in the base level if decks are not installed or if the decks are subsequently removed.

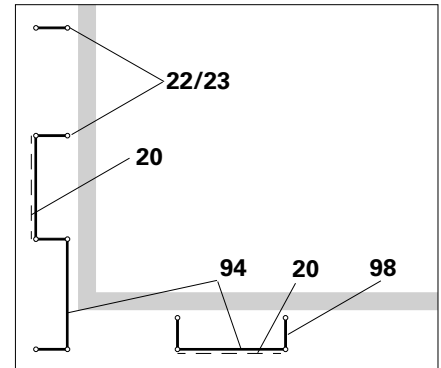

Fig. B6.01b

Arrangement of the Horizontal Ledgers UH-2 (94) in the base level if the decks remain in place.

B6 Corner configuration

7. Insert the Easy Standards EVM (22) with Guardrail EPG (51) into the next frame column. Fit Horizontal Ledger UH-2 67 (98).
8. Fit End Guardrail in Advance UPA 67 (52).
9. Fit Horizontal Ledger UH-2 (94a) onto the inner side of the continuous scaffold bay. Secure the wedges. (Fig. B6.02)

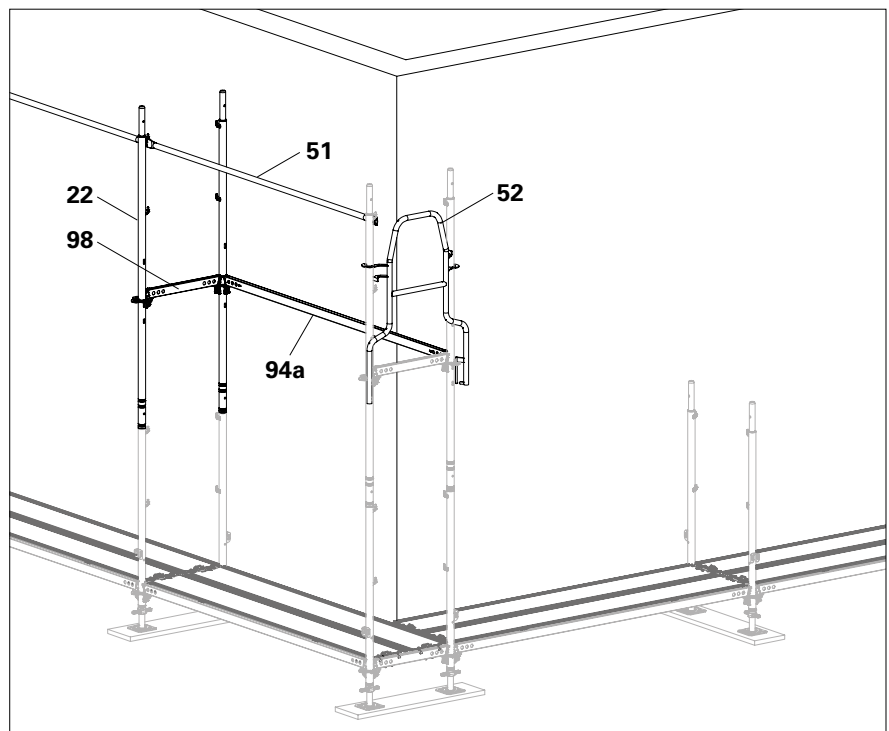

Fig. B6.02

10. Position the decks (30) excluding the corner bay.
11. Install Face Braces EBF (20). (Fig. B6.03)



- For the arrangement of horizontal ledgers and face braces, see Fig B6.01a + B6.01b.
- One diagonal will suffice in scaffold areas with 5 bays or fewer.

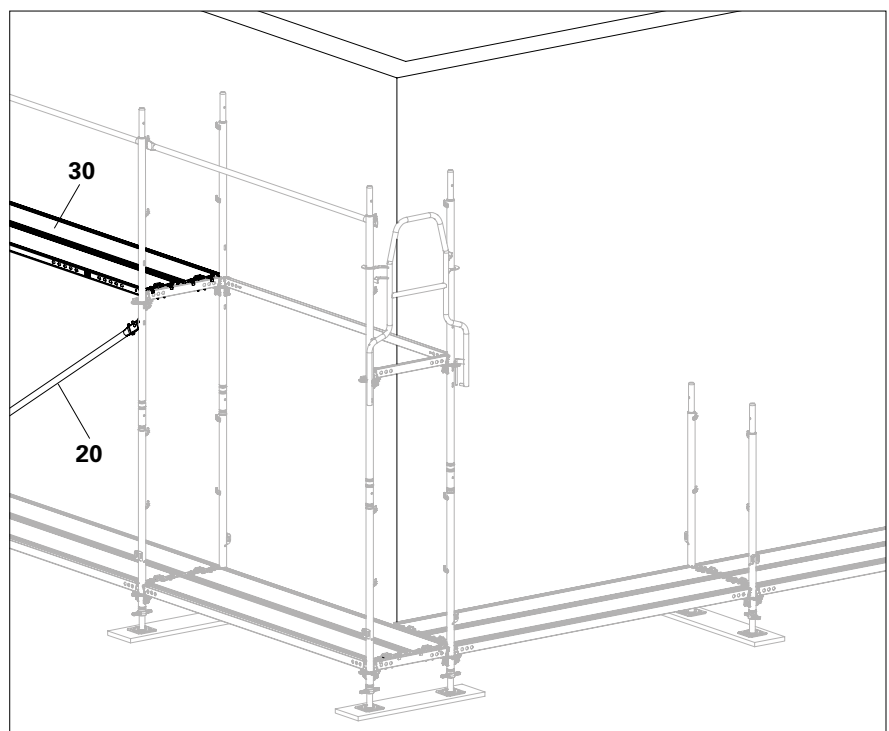

Fig. B6.03

Assembly of the adjacent scaffold bay

1. For the adjacent scaffold bay, attach Guardrail Post EPG (**51**) to the inwardly turned guardrail hook (**22.1**) of the Easy Standard EVM (**22**) from the level immediately below.
2. For the adjacent scaffold bay, fit Guardrail Post EPG (**51**) with another Easy Standard (**22a**).
3. On the inner side of the scaffold, fit another Easy standard (**22b**) and connect it to the horizontal ledger (**98**). (Fig. B6.04)

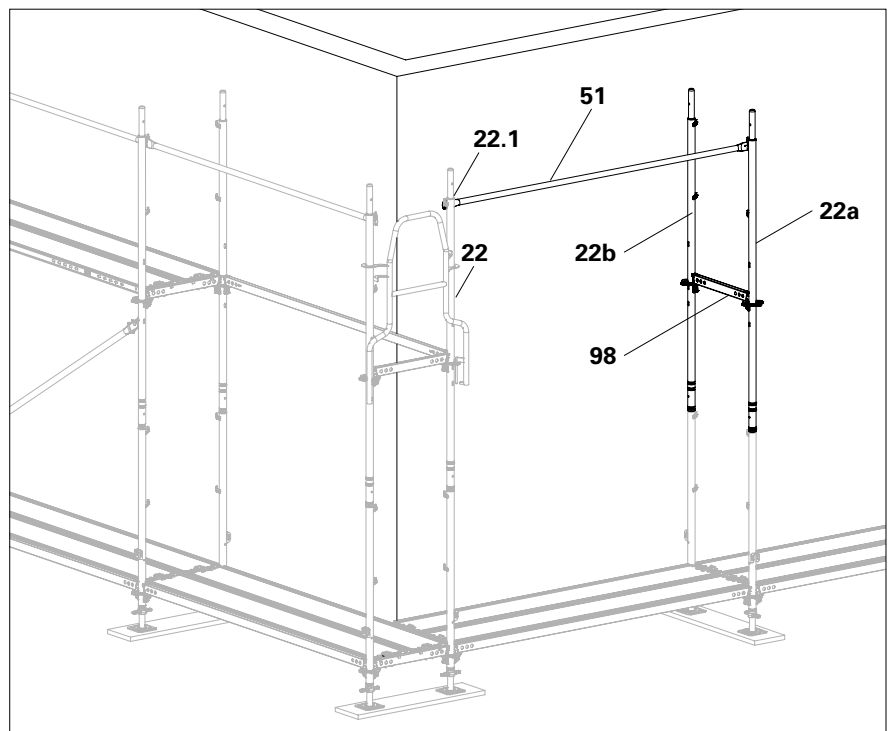

Fig. B6.04

3. Firstly, install decks (**30**) in the adjacent scaffold bay.
4. Install the remaining decks (**30a**). (Fig. B6.05)

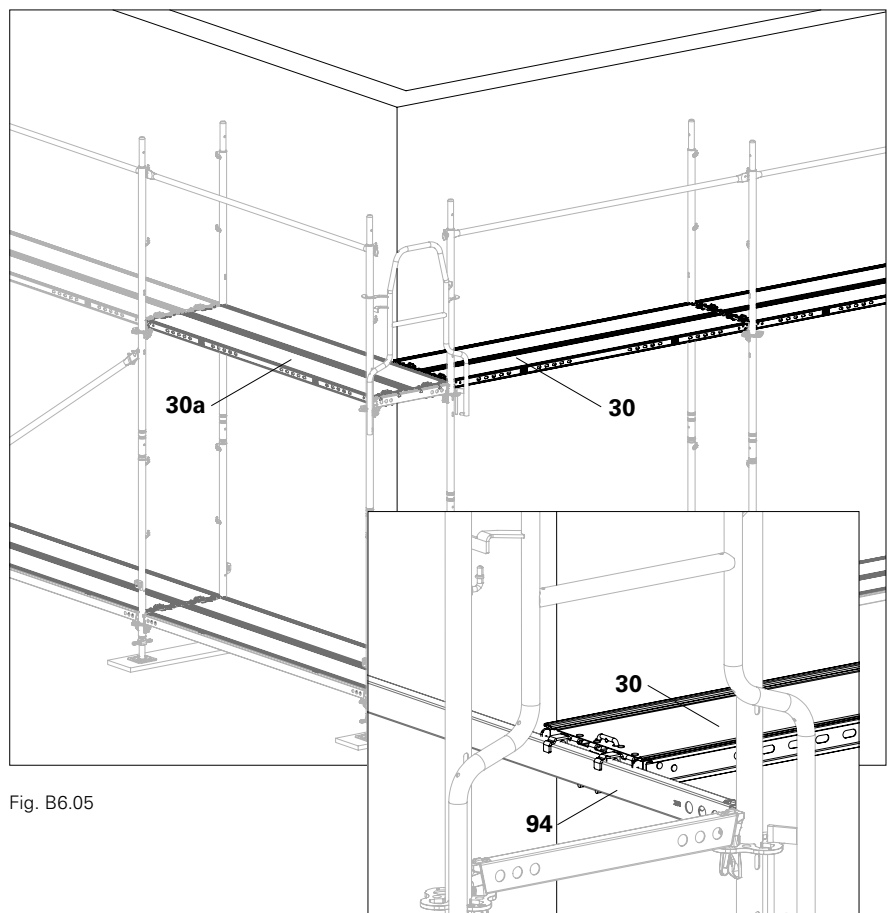

Fig. B6.05

5. Fit Face Brace EBF (20).
 6. Complete the lateral protection with intermediate guardrail (51) and Toe Boards UPF (56).
 7. Anchoring:
Anchor the respective adjacent external corner frame column (R) at a height distance of max. 4 m with
 - 2 wall ties, double installation or
 - 1 triangulated tie
 . (Fig. B6.06a)
- The external corner is now complete. (Fig. B6.06)

Components

18	Tube EVR
20	Face Brace EBF
22	Easy Standard EVM 200
30	Steel Deck EDS
51	Guardrail Post EPG
56	Toe Board UPF

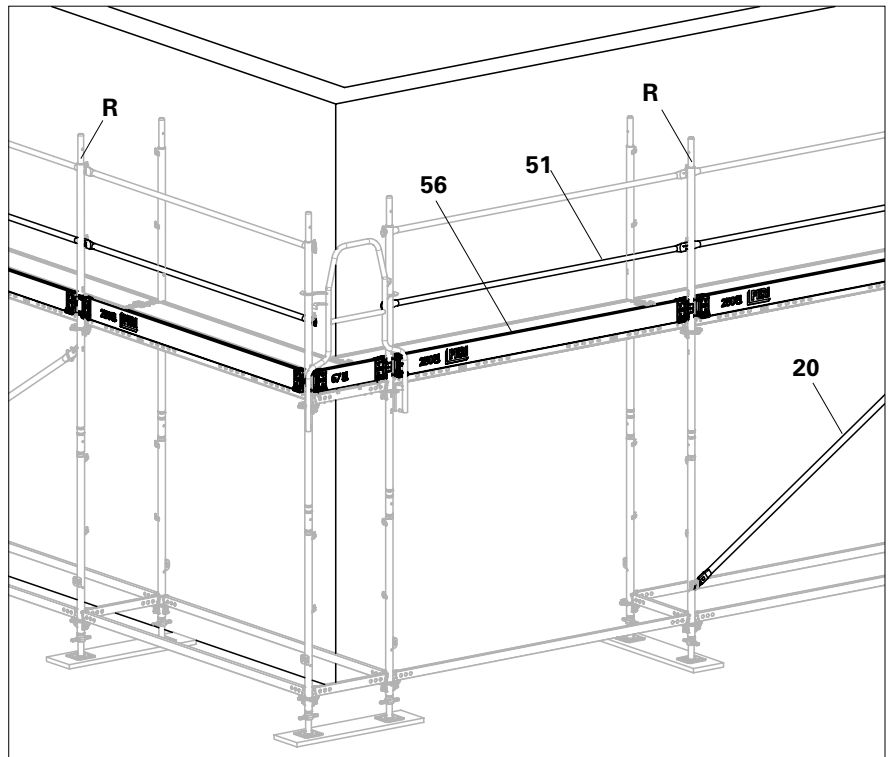

Fig. B6.06

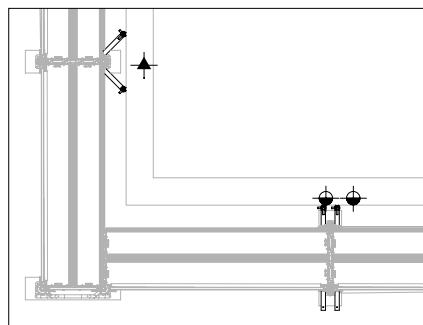

Fig. B6.06a

- ⊕ Wall tie
- ⚡ Triangulated tie

Inside corner

In this version of the assembly process, the decks on the base level are taken out again. (Fig. B6.07a)

Assembly of the base level

1. In the inner corner, assemble four Easy Base Standards EVS (**23**) with four Horizontal Ledgers UH-2 (**98**) to form a corner tower. Hammer all wedges into place.
2. In each case, connect the next frame column using two Horizontal Ledgers UH-2 (**94**).

(Fig. B6.07 + B6.07a)

Components

20	Face Brace EBF
22	Easy Standard EVM 200
23	Easy Base Standard EVS 124
51	Guardrail Post EPG
56	Toe Board UPF
94	Horizontal Ledger UH-2 300
98	Horizontal Ledger UH-2 67

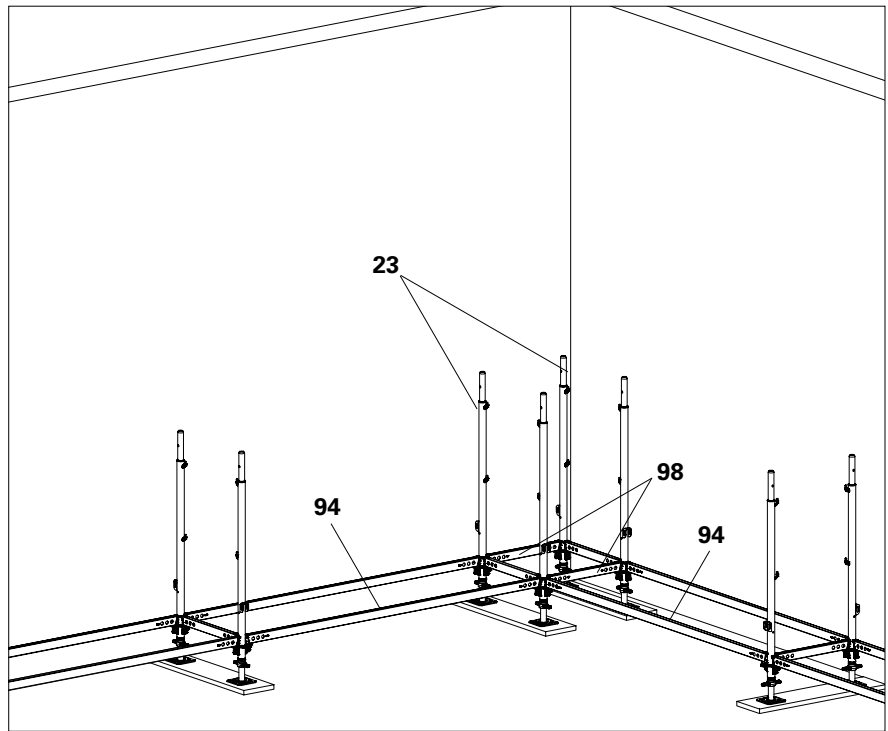

Fig. B6.07



- For the arrangement of horizontal ledgers and face braces, see Fig B6.07a + B6.07b.
- One diagonal will suffice in scaffold areas with 5 bays or fewer.

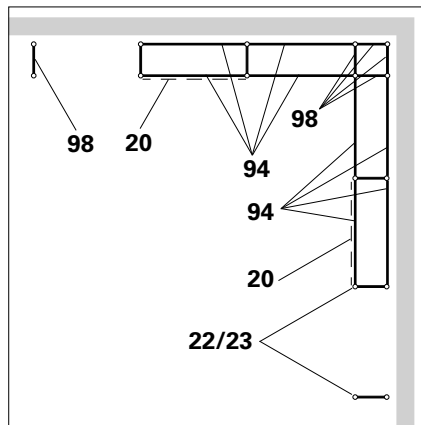

Fig. B6.07a

Arrangement of the Horizontal Ledgers UH-2 (**94**) in the base level if decks are not installed or if the decks are subsequently removed.

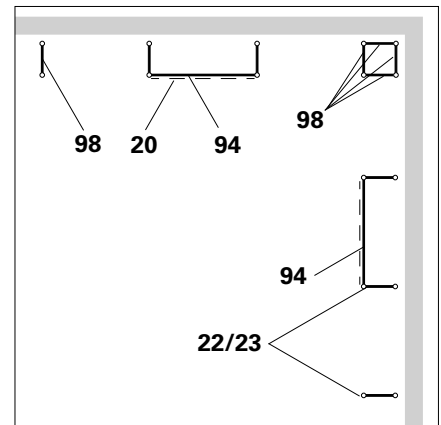

Fig. B6.07b

Arrangement of the Horizontal Ledgers UH-2 (**94**) in the base level if the decks remain in place.

Assembly of Easy standards and guardrail post

1. Pre-assemble two Guardrail Couplings EPR (58) on an Easy Standard EVM (22a).
 - Fit the guardrail hook of the Guardrail Couplings EPR at the same height as the guardrail hook turned by 90° on the Easy Standard.
 - The guardrail hook of the Guardrail Couplings EPR subsequently points to the inner side of the scaffolding in the second scaffold bay.
2. Place the pre-assembled Easy standard (22a) on the front base standard (23).
3. Fit other Easy standards (22). Note the alignment of the guardrail hooks.
4. Connect Easy standards with Horizontal Ledger UH-2 67 (98). Secure the wedges.
5. Attach Guardrail Post EPG (51) for the first scaffold bay (A) to the guardrail pin of the Easy standard (22a) from the level immediately below.
6. Fit the other side of the Guardrail Post EPG onto the Easy Standard EVM (22b), and then place in position.

(Fig. B6.08)

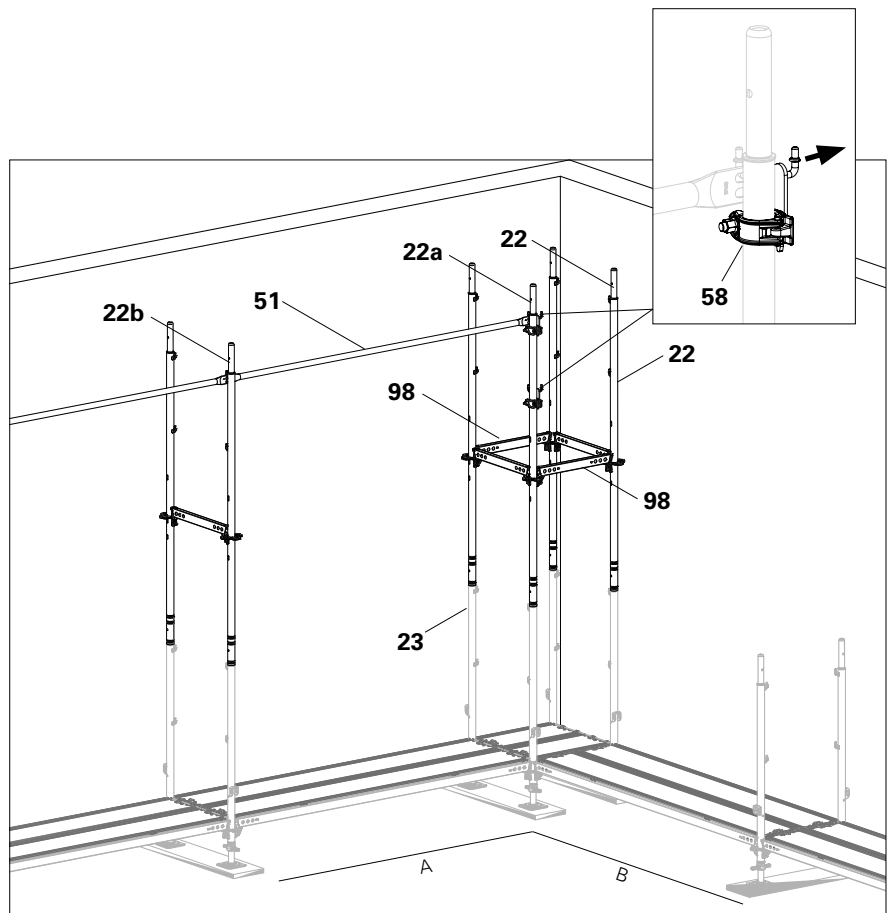

Fig. B6.08

7. For the second scaffold bay (B), attach the Guardrail Post EPG (51) to the Guardrail Coupling EPR (58) from the level immediately below.
8. Fit the other side of the Guardrail Post EPG onto the Easy Standard (22), and then place in position together.

(Fig. B6.09)

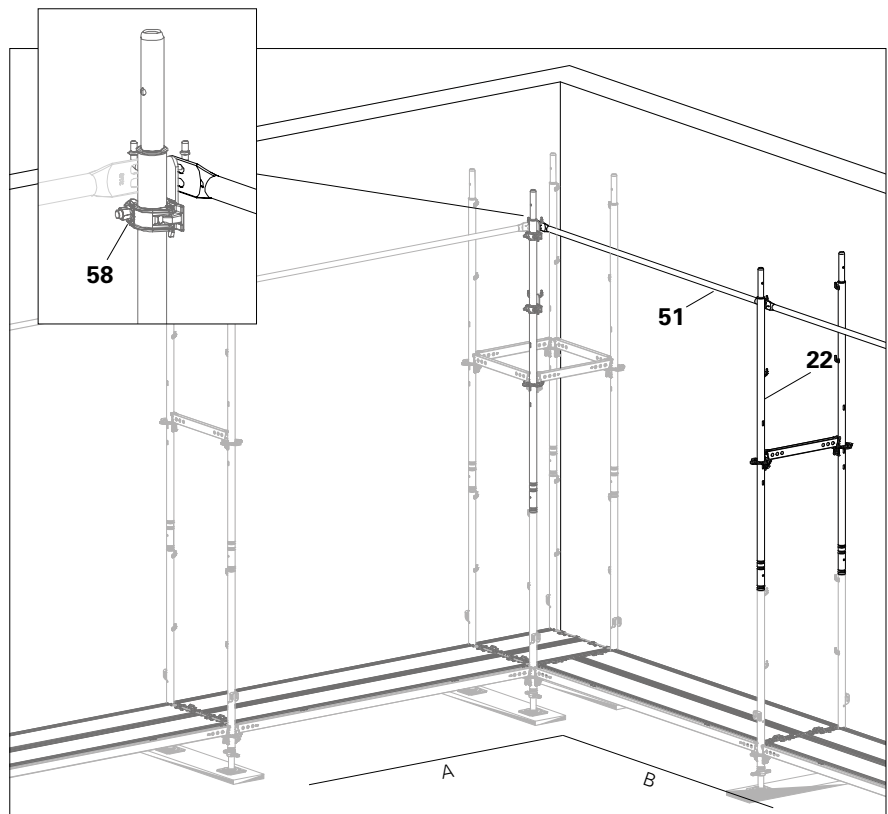

Fig. B6.09

Assembly of decks and braces

1. Install decks (**30**) in the first and second scaffold bays.
 2. Install two Steel Decks EDS 33 x 67 (**35**) or Aluminium Deck EDA 67 in the inside corner.
 3. Fit Face Braces EBF (**20**).
 4. Complete the lateral protection with intermediate guardrail (**51**) and toe board (**56**).
- The inside corner is finished.
(Fig. B6.10)

Components

20	Face Brace EBF
30	Steel Deck EDS
35	Steel Deck EDS 33 x 67
51	Guardrail Post EPG
56	Toe Board UPF

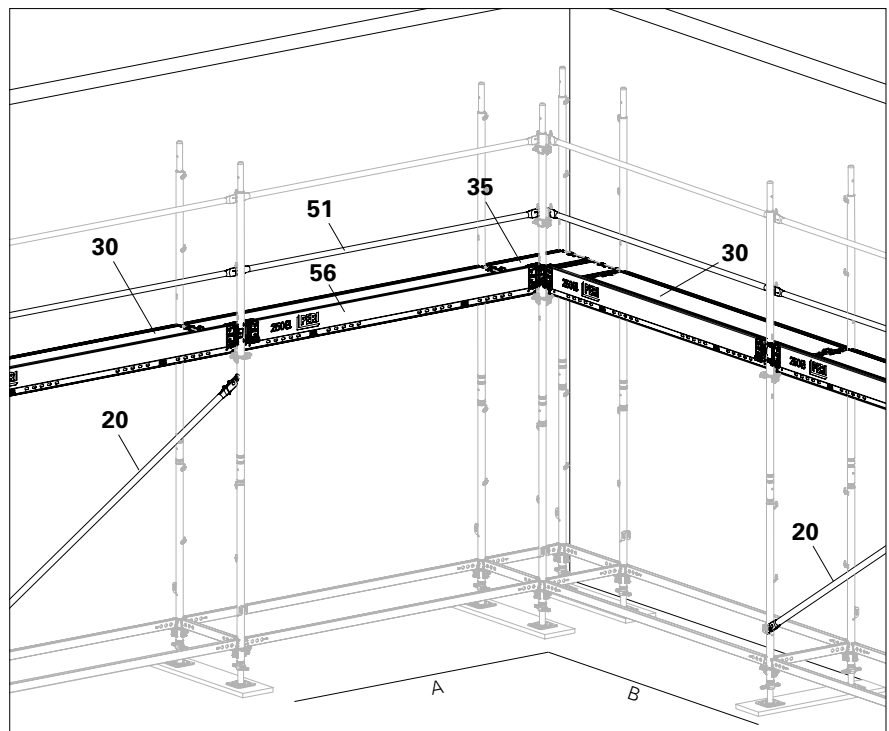

Fig. B6.10

General



- Carry out longitudinal infills in a longitudinal bay. Longitudinal infills in corner areas require project-specific planning.
- Plan the lengths of the adjacent scaffold bays in such a way that the maximum infill length is not exceeded
- Erect the scaffolds to the right and left of the filler area as stand-alone scaffolding. Anchor the edge standards according to the respective tie pattern. (Fig. B7.01)
- Set up the individual scaffolds level by level and connect them using longitudinal infills.

Assembly sequence

1. Secure the edge bays of both scaffolds with Advance Guardrail UPA.
2. Fit Deck Compensation EDL 33 from the scaffold level immediately below, see the following section.
3. Working from the protection of the Advance End guardrail: fit the guardrail and intermediate guardrail, see the following Section.
4. Fit the toe board, see the following section.
5. Remove the end guardrails in advance and install them on the next scaffold level.

Using the tie patterns

Example arrangement with tie pattern for equipment variation 1a "A"

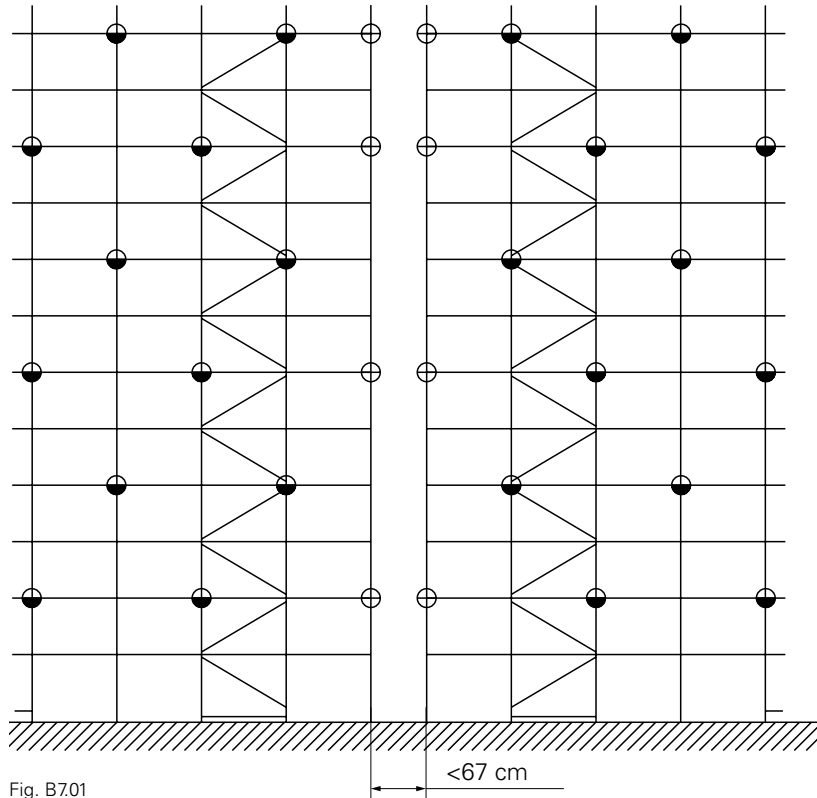

Fig. B7.01

Deck Compensation EDL 33

Technical data

- Maximum length of the compensation bay 67 cm
- max. load class 4 according to EN 12811 ($p = 3.0 \text{ kN/m}^2$)
- The longitudinal infill does not have any bracing function.
→ Comply with the tie pattern!

Assembly

The Deck Compensation EDL 33 (**33**) is installed from a safe position on the scaffold level immediately below.

1. On one side of the scaffolding, place the shiftable side (**33.1**) on the stand-ard decking and shift the deck compensation towards the crossbar. (Fig. B7.02)
2. Turn the securing bracket (**33.2**) approx. 90° and place it on the cross-bar 60 x 30 with the claw.
3. Release the securing bracket.
→ The securing bracket drops down and secures the Compensation EDL 33.
→ The compensation deck is installed. (Fig. B7.03 + B7.03a)

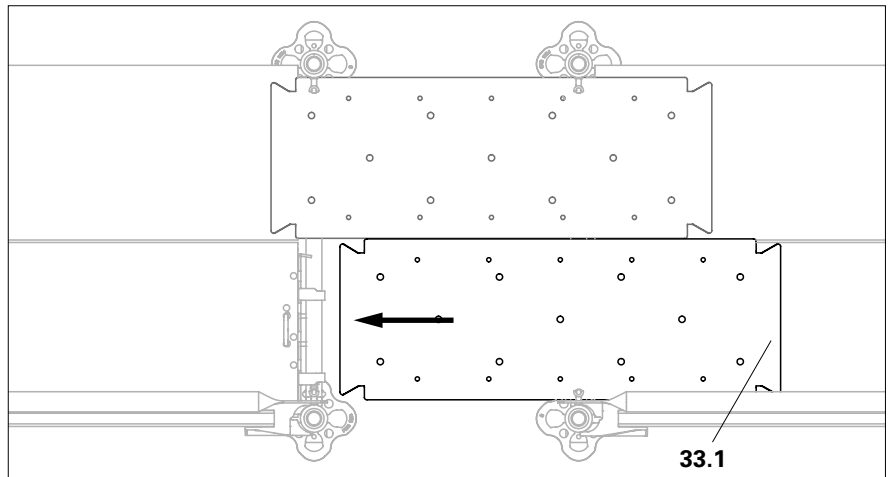

Fig. B7.02

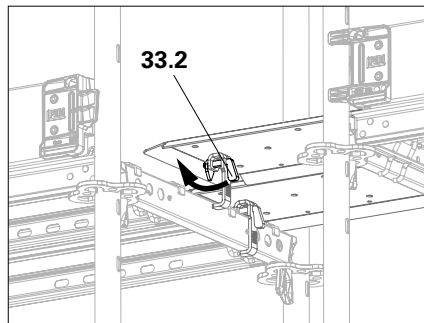

Fig. B7.03

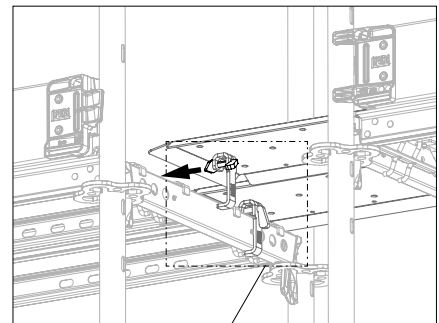
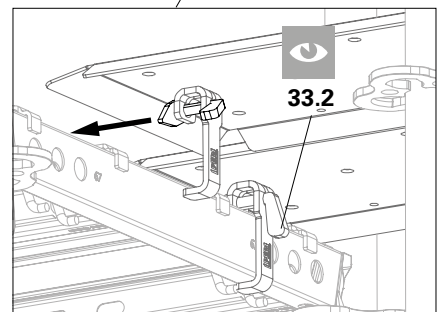

Fig. B7.03a



Is the securing bracket (**33.2**) hanging in a perpendicular position? If not, turn it by hand.



The Deck Compensation EDL 33 cannot be mounted on Console Brackets ECM 33, only on Supports UCS 33.

Guardrail Posts

Variant 1

Mount the scaffold tubes onto the Easy Standards with standard couplers. (not shown)

Variant 2

1. On one side, fit Guardrail Post EPG 100 or 150 (51) onto the guardrail connection of the Easy Standard (22).
2. On the other side, fit it onto the guardrail post that is already attached to the standard bay using a half-coupler or wall tie coupling (45).
 - Clamp the flat connection piece of the guardrail post into the screw connection of the coupling.
 - Fit the coupling in such a way that the projecting screw points outwards.

→ The guardrails posts are now installed.

(Fig. B.704 + B.705)

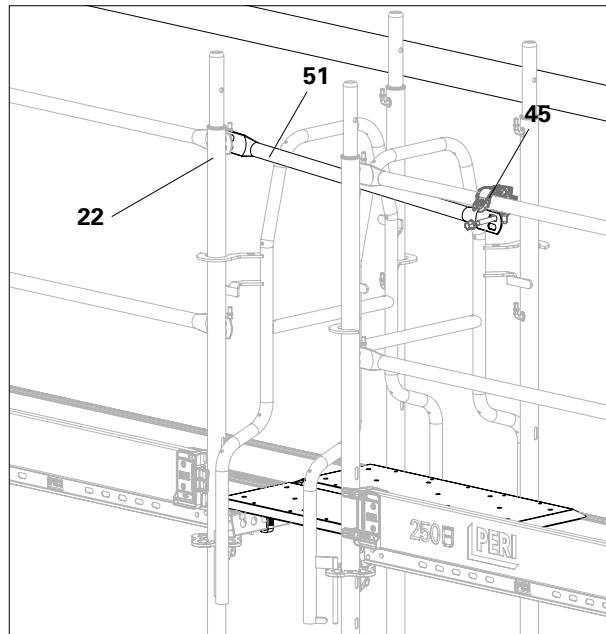

Fig. B.704

Toe boards

On the longitudinal infill, fit the toe board onto the Easy Standard using suitable means or screw it onto the adjacent toe boards.



Dismantle the End Guardrail in Advance UPA (52) last.

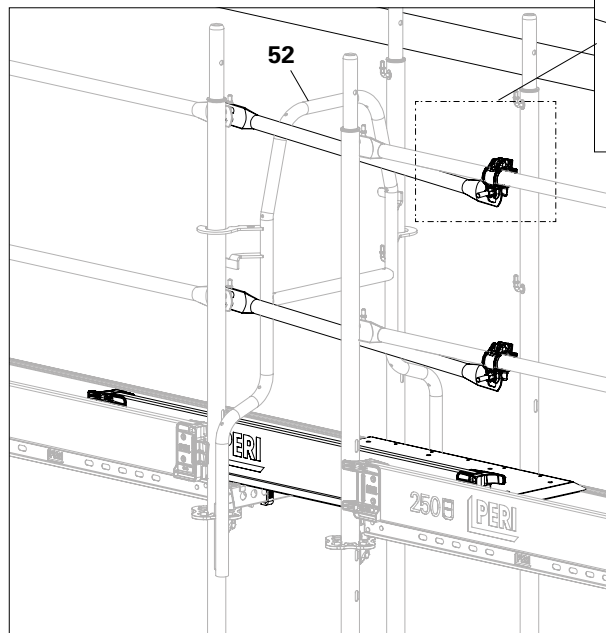

Fig. B.705

Toe Board Compensation UPY-L

With the Toe Board Compensation UPY-L (111) and two Toe Boards UPY (57), it is possible to fit a Toe Board that is continuously adjustable in terms of its length. (Fig. B7.06)
 Toe Boards with different lengths may be used.

Technical data

- **Maximum length: 5.00 m**
- **Overlap**
 - up to length 1 m: L = 20 cm
 - length of 1 m and higher: L = 50 cm

Assembly

1. Slide the Toe Board Compensation UPY-L (111) onto the first Toe Board UPY (57). (Fig. B7.07)
2. Slide the second Toe Board UPY (57) between the Toe Board UPY and Toe Board Compensation UPY-L in an overlapping position.
3. Pull the boards to the required length between the standards of the compensation bay.
4. Align the Toe Board Compensation UPY-L centrally at the overlap.
5. Tighten the wing nut.
 - The toe board is installed. (Fig. B7.08)



For distances less than 25 cm, screw a wooden board to the inside of the toe boards. Use the existing screw holes in the toe boards. (Fig. B7.08a)
 Alternatively, close the gap elsewhere on site.

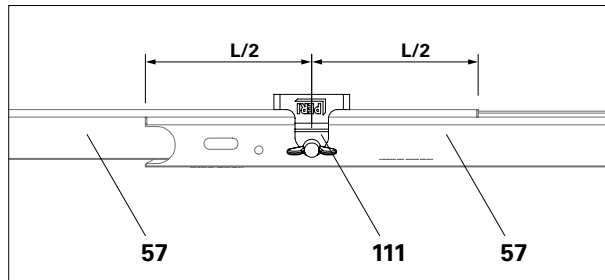

Fig. B7.06

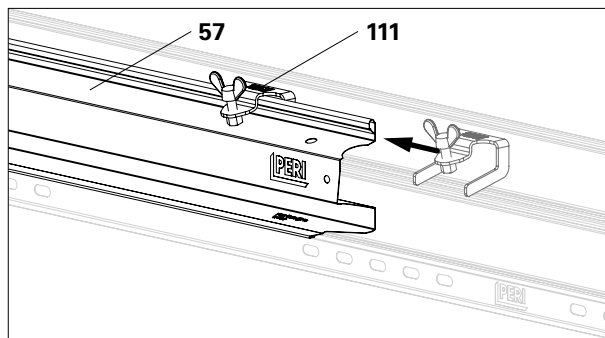

Fig. B7.07

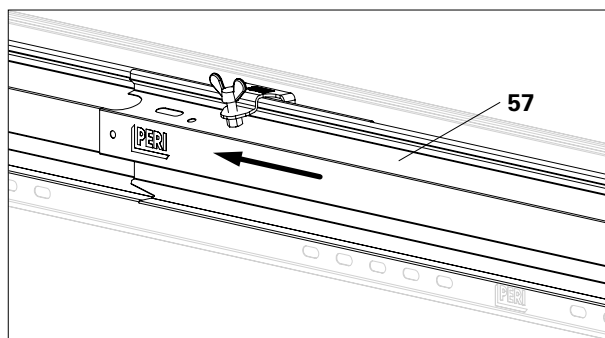

Fig. B7.08

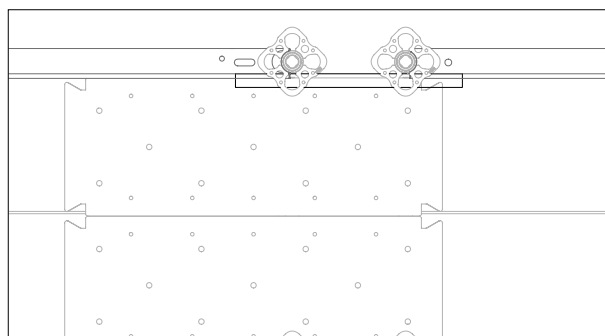

Fig. B7.08a

Cover Plate UDP

Cover Plates UDP (**39**) are available for scaffold widths 67 cm, 75 cm and 100 cm.



- Max. LC3 in the transition area.
- Create lateral protection in the transition area individually. Use PPE.

Assembly

- From a safe position on the scaffold level immediately below:
1. Connect partial scaffolds at the greater distance with Horizontal Ledger UH-2 (**98**).
 2. Thread the Cover Plate UDP (**39**) through the gap and place it between the subframes on top of both deck sides.
 3. Pull the wedge (**39.1**) out of the clamping part (**39.2**) and lower the clamping part over the horizontal ledger (**98**).
 4. Insert the wedge into the clamping part and hammer it tight.
- Cover plate is installed. (Fig. B7.09 – B7.09b)

Application examples

- Bridging of scaffolding parts that are not in alignment, e.g. due to the shape of the building.

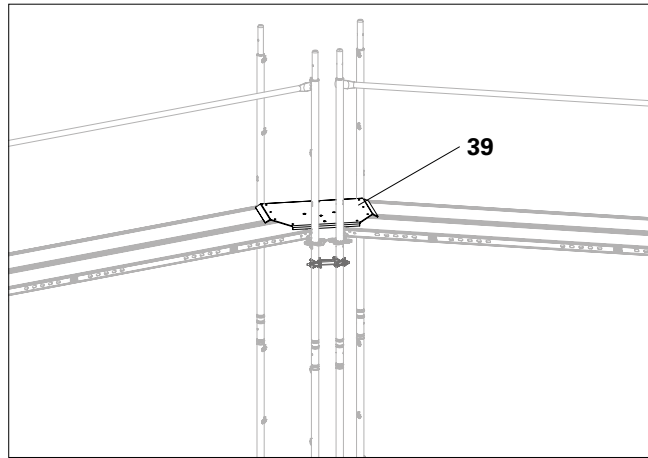

Fig. B7.09

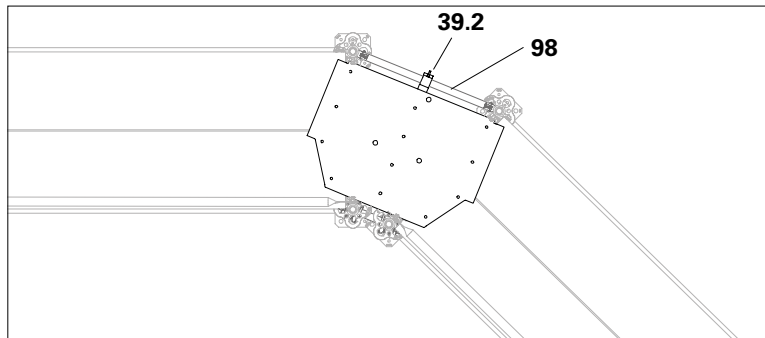

Fig. B7.09a

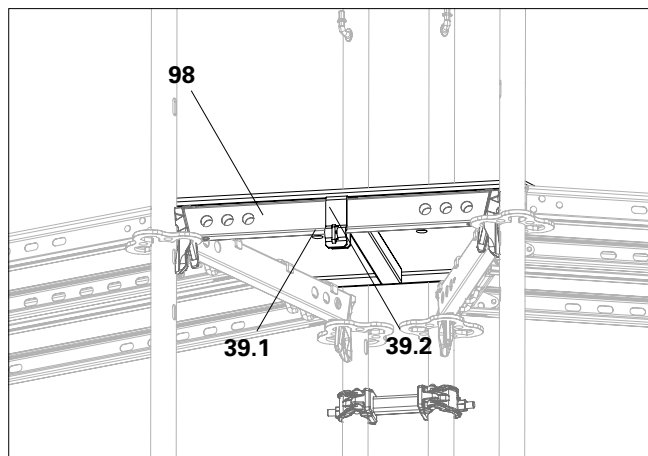

Fig. B7.09b

External access with staircase

The scaffold access can be realised in two ways.

The following section describes the version involving Easy Standard EVM and Stair Guardrail EAG.

For the version with Standard UVR and Horizontal Ledger UH-2, see Section H examples "External access" on page 241.

- Follow the prescribed assembly sequences!
- The scaffold access grows in line with the basic scaffold.
- If all bays in the basic scaffold are to be >LC3, external access must be fitted.
- Do not set any objects down on the scaffold access.

The staircases are intended for scaffold bays with 2.50 m and 3.00 m widths. Length-determining components, e.g. Horizontal Ledger UH-2, must be selected accordingly.

Both versions are assembled in the same way. (Fig. B8.01)



- When erecting the basic scaffold in this bay, the guardrail in advance is assembled last as this will be dismantled again later.

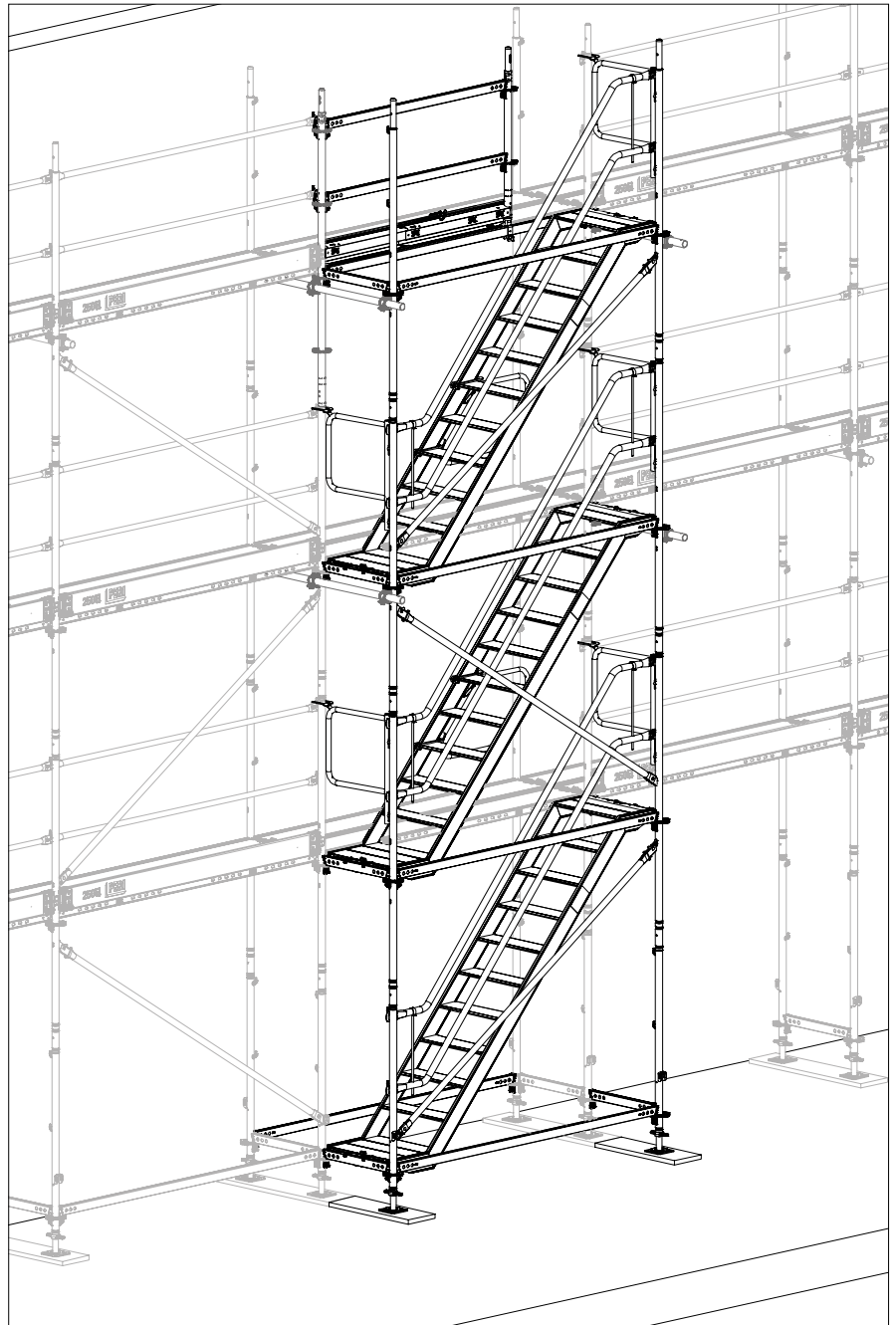

Fig. B8.01

Assembly of the base level

1. Fit Horizontal Ledger UH-2 (**94**) on the inner side of the basic scaffold in the base level. Secure the wedges.
2. Position Base Spindles UJB (**10**) 67 cm apart.
3. Position Easy Base Standards EVS (**23**) on Base Spindles UJB (**10**).
4. Connect Easy Base Standards EVS (**23**) to the basic frame with Horizontal Ledgers UH-2 67 (**98**). Do not secure the wedges yet.
5. Connect Easy Base Standards EVS with Horizontal Ledgers UH-2 (**94a**). Do not secure the wedges yet.
6. Horizontally align the base level using a spirit level.
7. Hammer all wedges into place.
→ The base level is now installed.
(Fig. B8.02)

Components

- | | |
|-----------|----------------------------|
| 10 | Base Spindle UJB |
| 23 | Easy Base Standard EVS 124 |
| 94 | Horizontal Ledger UH-2 300 |
| 98 | Horizontal Ledger UH-2 67 |

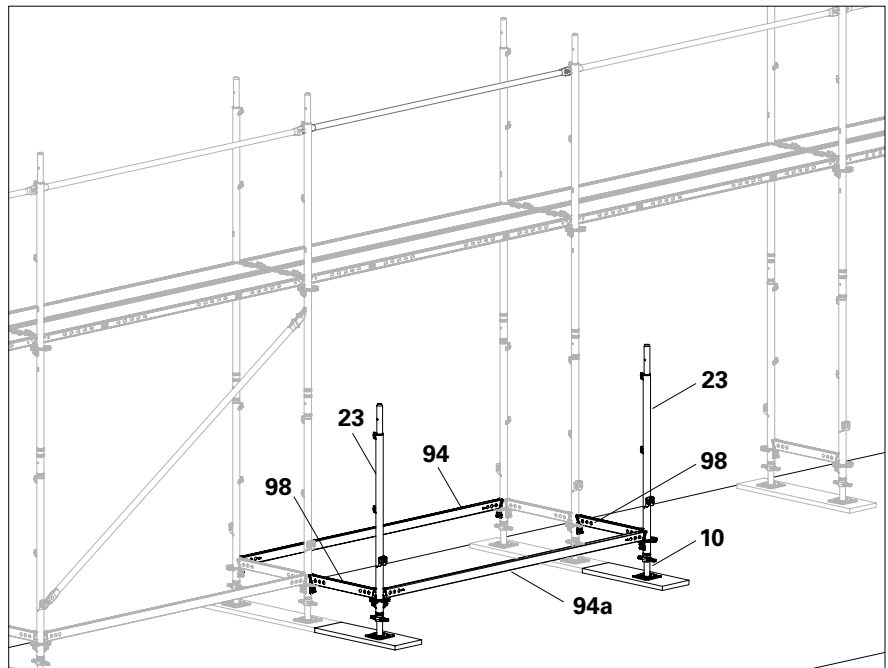

Fig. B8.02

Assembly of the first staircase

1. Pre-assemble End Guardrails EPF (54) on an Easy Standard EVM (22).
 2. Fit Easy Standard EVM (22) with pre-mounted end guardrail (54) onto Easy Base Standard EVS (23).
 3. Fit Horizontal Ledger UH-2 67 (98) between Easy Standard (22) and base scaffold as an upper stair support. Secure the wedges.
 4. Fit the second Easy Standard (22a) onto the base standard.
- (Fig. B8.03)

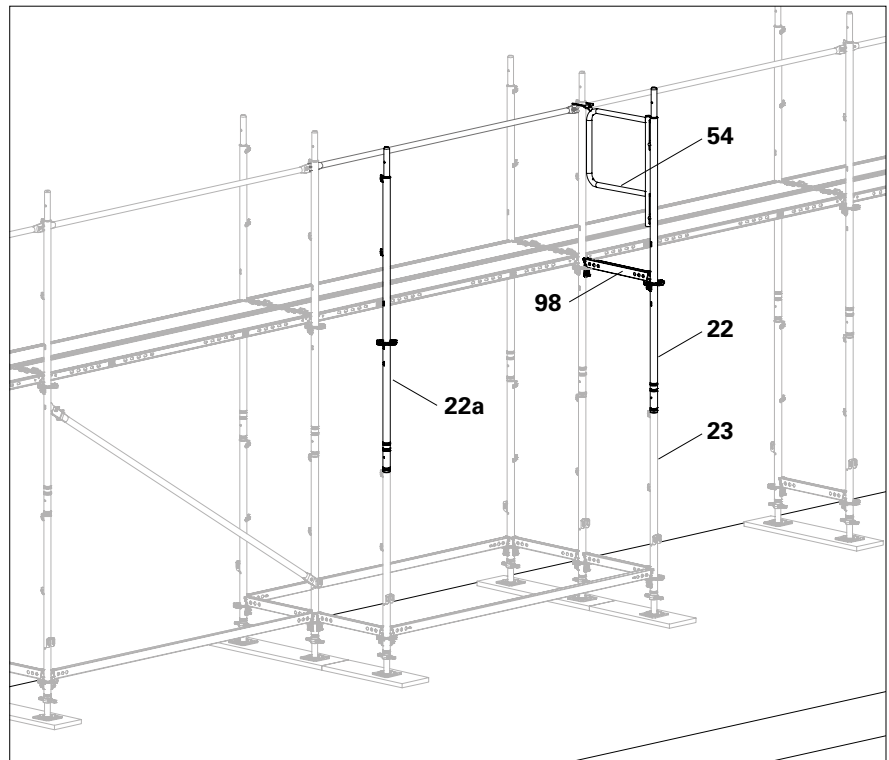

Fig. B8.03

5. Fit two Stair Guardrails EAG (77) between the Easy standard (22) and base standard (23a). See Section "Stair Guardrails EAG" on page 23.
 6. At the step at the bottom, connect both Stair Guardrails EAG (77) with Locking Pin EAG (79). To do so, insert the locking pin through the holes of the guardrail posts.
 7. Attach Stair Tower UAS/EAS (76) firstly to the top Horizontal Ledger UH-2 67 and then to the bottom one.
- (Fig. B8.04)

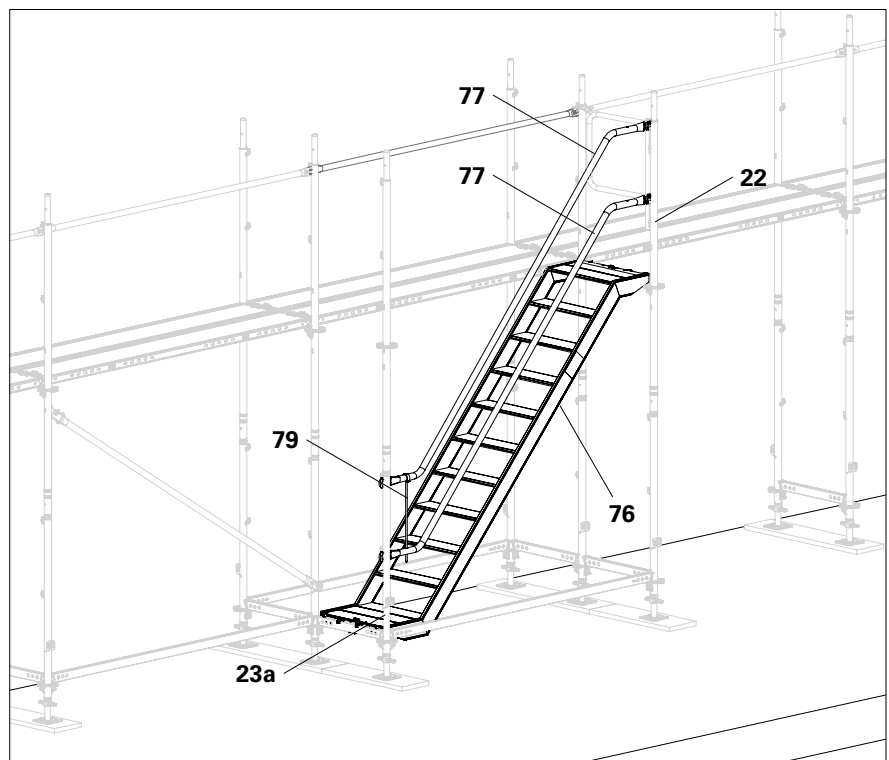

Fig. B8.04

Components

22	Easy Standard EVM 200
23	Easy Base Standard EVS 124
54	End Guardrail EPF 67
76	Stair Tower UAS/EAS
77	Stair Guardrail EAG
79	Locking Pin EAG
98	Horizontal Ledger UH-2 67



Have both lift locks (**76.1**) of the staircase dropped beneath the crossbar? If not, lift the staircase slightly and let it drop into position or operate the lift lock manually. (Fig. B8.04a)

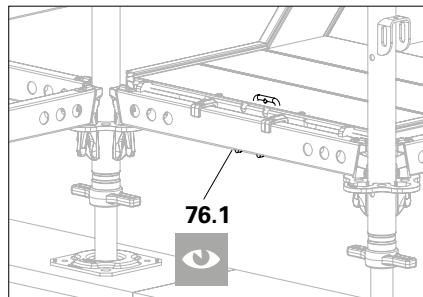

Fig. B8.04a



Optional:

- A Stair Guardrail UAG can also be mounted on the inside of the staircase.
- Fit a Toe Board UPY 67 or Toe Board UPF 67 at the front sides of the staircase.

8. Brace both outer legs using a face brace (**20**) and horizontal ledger (**94+98**).
 9. At the step at the top, connect both Stair Guardrails EAG (**77**) with Locking Pin EAG (**79**).
- The first staircase is now installed. (Fig. B8.05)



- The guardrail post (**51**) of the basic scaffold remains in place until the next stair level is installed.
- To access the upper scaffold level, detach the guardrail post (**51**) on the side of the stair exit, enter the scaffold level and then reattach it straight away.

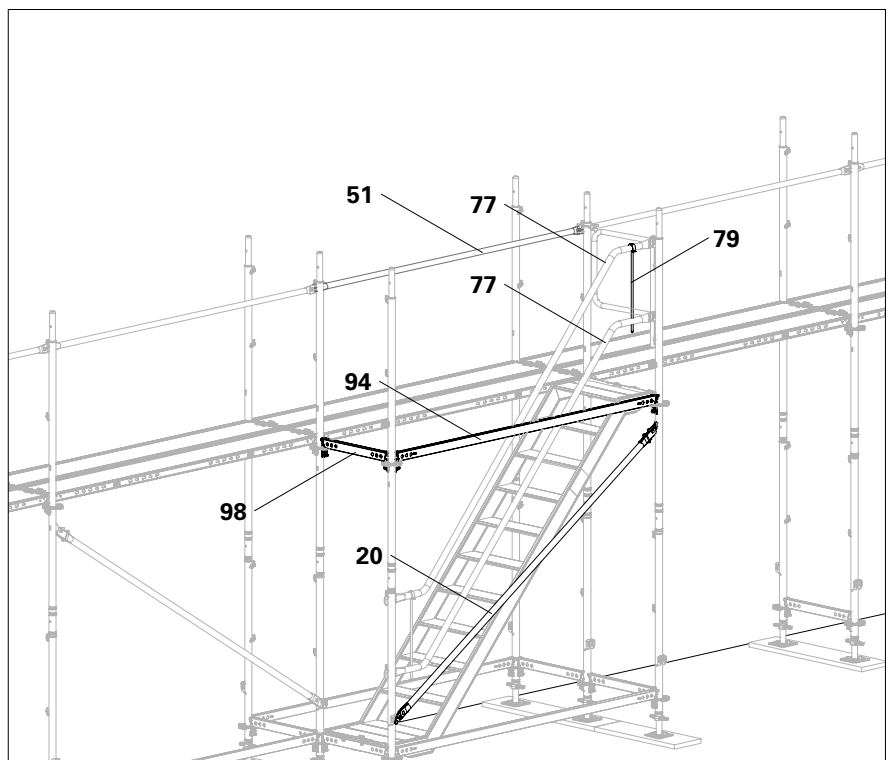

Fig. B8.05

Assembly of additional staircases

1. Fit two Easy standards (**22**) to the basic scaffold and connect them to the horizontal ledger (**98**).
 2. As described for the base level, fit the Easy Standard EVM (**22a**) with pre-mounted end guardrail (**54**) and Horizontal Ledger UH-2 67 (**98a**).
 3. Install Stair Tower UAS/EAS (**76**) from the staircase below.
- (Fig. B8.06)

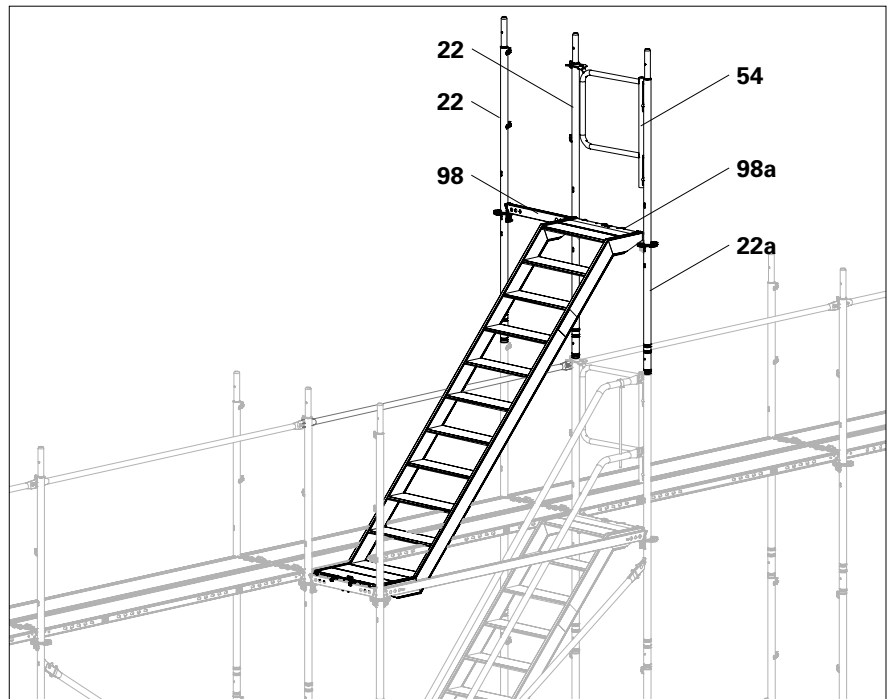

Fig. B8.06

- From the basic scaffold:
4. Fit two Stair Guardrails EAG (**77**) and connect them on the entrance side with a locking pin (**79**).
 5. Fit the End Guardrail EPF (**54**).
 6. Fit Stair Guardrail UAH-2 (**78**) onto the internal side of the staircase.
 7. Remove guardrail (**51**) from the basic scaffold.
- (Fig. B8.07)

Components

22	Easy Standard EVM 200
51	Guardrail Post EPG
54	End Guardrail EPF
76	Stair Tower UAS/EAS
77	Stair Guardrail EAG
78	Stair Guardrail UAH-2
79	Locking Pin EAG
98	Horizontal Ledger UH-2 67

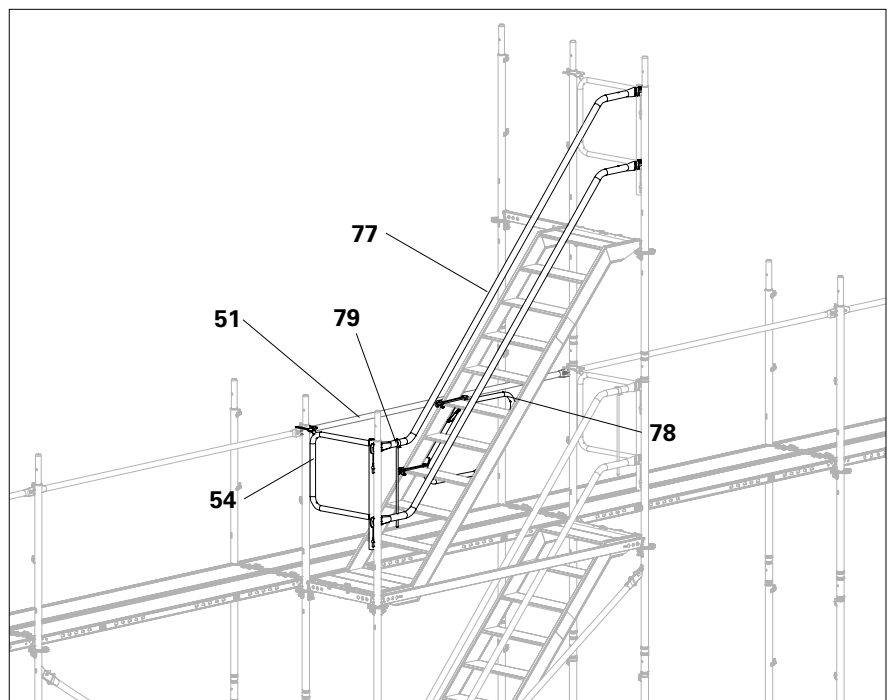

Fig. B8.07



The Stair Guardrail UAH cannot be mounted on the Flex Stair UAS-2 or Easy Stair EAS.

Installing an additional scaffold level

1. Complete the lateral protection on the existing scaffold level.
 2. Assemble the next scaffold level.
 3. Connect the Stair Guardrail EAG (77) at the top with a locking pin (79).
- The scaffold level and staircase are now installed.

(Fig. 8.08)

Install additional scaffold levels and staircases in the same way.

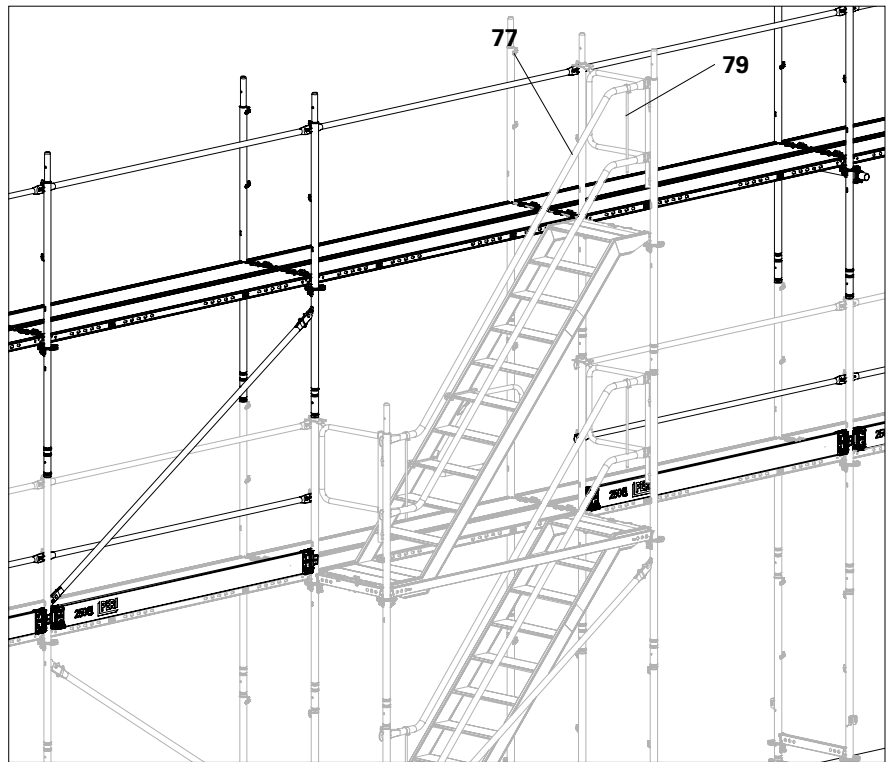

Fig. B8.08

Bracing

Brace the scaffold staircase at every level with a horizontal ledger (**94**) and face brace (**20**).

Anchoring

Anchor the scaffold staircase in accordance with the tie pattern, see Section "E3 Tie pattern" on page 166. Anchor the two frame columns of the external scaffold access:

- Anchor Wall Tie UWT (**46**) with one Wall Tie Coupler EWC (**45**) or standard coupler to both Easy Standards (**22**) of the basic scaffold, as well as the Easy Standard of the staircase (**22a**).

(Fig. B8.09)

Components

- 20** Face Brace EBF
- 22** Easy Standard EVM 200
- 45** Wall Tie Coupler EWC
- 46** Wall Tie UWT
- 59** Guardrail Holder EPW
- 83** Standard UVR 200
- 94** Horizontal Ledger UH-2 300
- 98** Horizontal Ledger UH-2 67

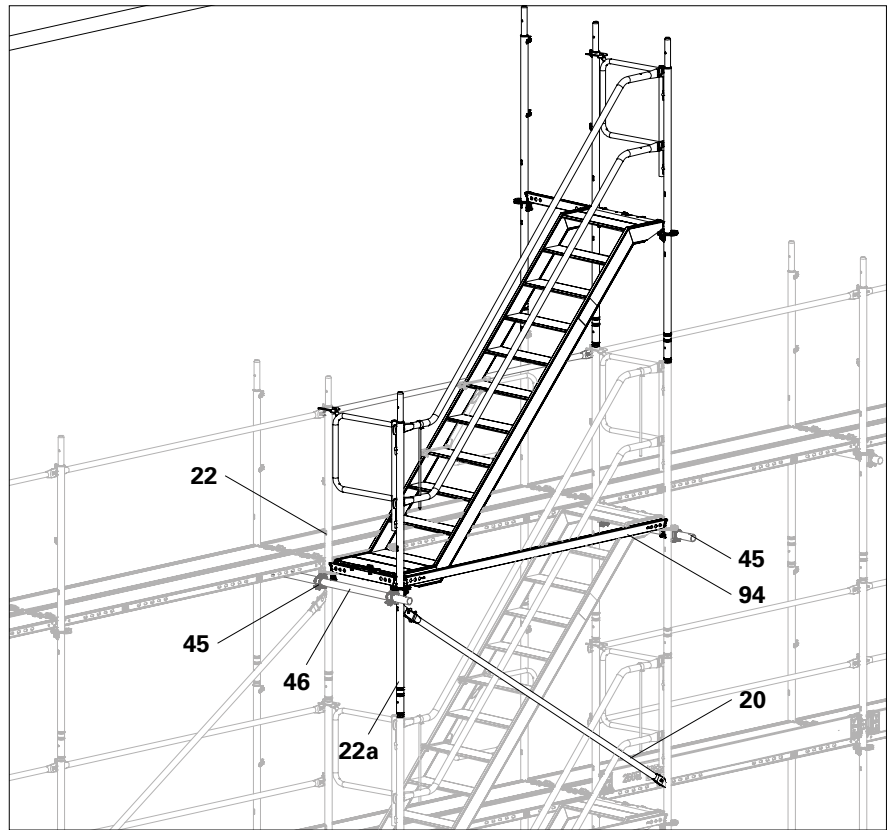

Fig. B8.09

Top staircase

Always anchor and brace the uppermost staircase.

Fit a Standard UVR 200 (**83**) with pre-mounted Guardrail Holder EPW (**59**) onto the basic scaffold as an outer leg in place of the Easy standard.

Assemble the uppermost staircase in the same way as an additional staircase, and in addition:

1. Fit an Easy Standard EVM (**22**) and connect it to the basic scaffold with a Horizontal Ledger UH-2 (**98**).

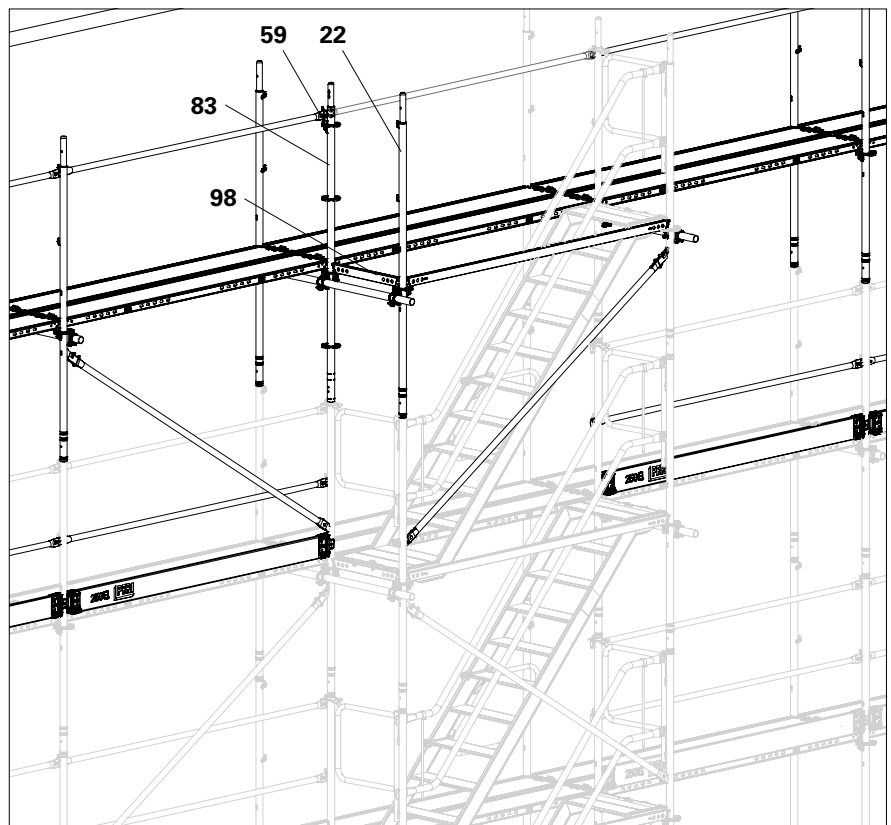

Fig. B8.10

Guardrails

1. Prior to installing the deck on the top level of the basic scaffold, fit a Horizontal Ledger UH-2 (**94**) onto the outer side.
 2. Attach the UH Spigot-2 (**93**) to the horizontal ledger so that the wedge can be secured from the outside. (Fig. B8.11a)
 3. Fit a Standard UVR 100 (**85**) onto UH Spigot-2.
 4. Fit Horizontal Ledger UH-2 (**95**) between Standards UVR (**83 + 85**).
 5. Align UH Spigot-2 (**93**) and secure the wedge. (Fig. B8.11 + B8.11a)
 6. Complete the lateral protection in the basic scaffold: Fit horizontal ledgers (**95a**) as intermediate guardrails as well as Toe Boards UPY (**57**).
 7. For the adjacent scaffold bay, fit a Guardrail Holder EPW (**59**) and a Guardrail Post EPG (**51**) as an intermediate guardrail.
- The top staircase is now installed. (Fig. B8.12)

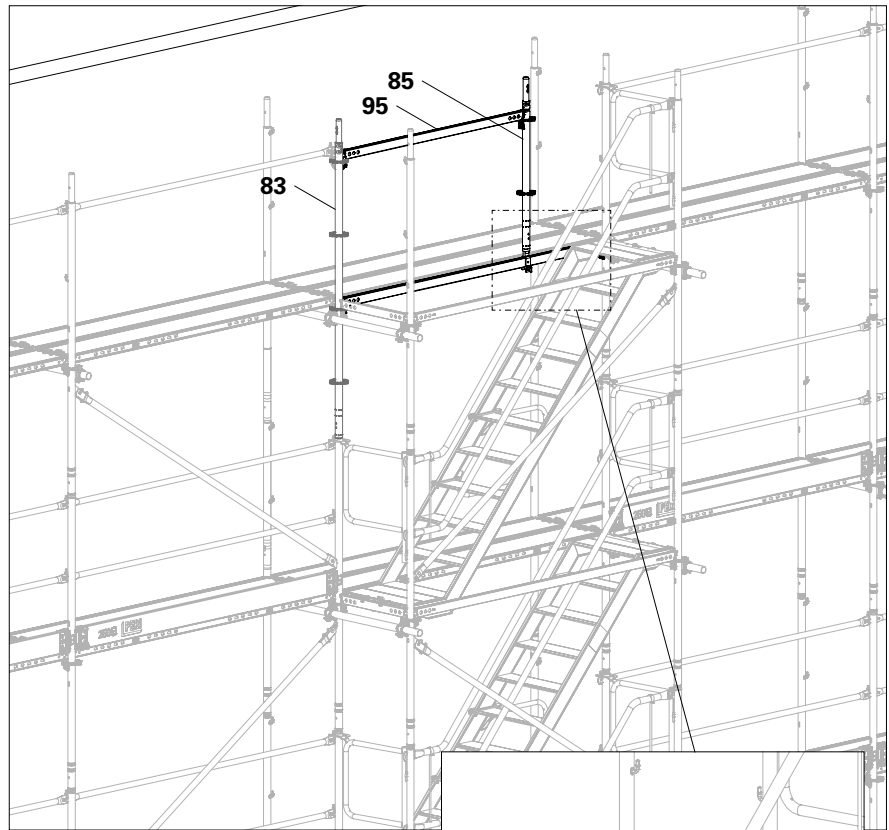

Fig. B8.11

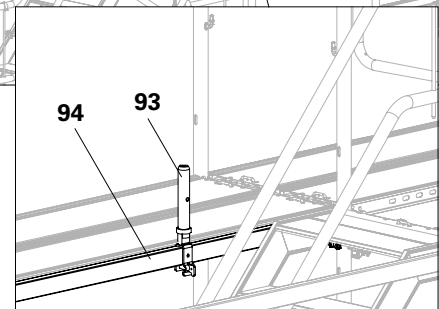

Fig. B8.11a

Components

- 22** Easy Standard EVM 200
- 50** Guardrail Post EVP
- 51** Guardrail Post EPG
- 56** Toe Board UPF
- 59** Guardrail Holder EPW
- 83** Standard UVR 200
- 85** Standard UVR 100
- 93** UH Spigot-2
- 94** Horizontal Ledger UH-2 250
- 95** Horizontal Ledger UH-2 175

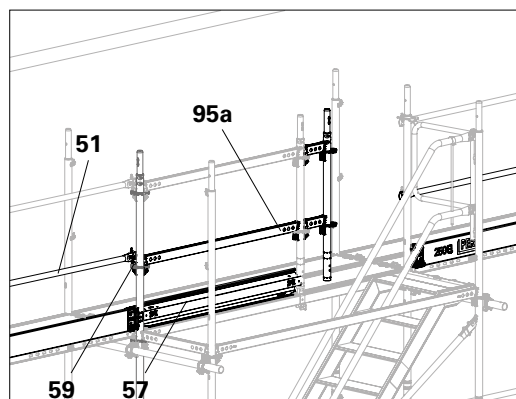

Fig. B8.12

Internal access with access deck

For bay lengths of 2.50 m and 3.00 m, install the Access Decks EAW-L, EAW-2-L, EAC-L or EAA-L (40) (with attached access ladder) in the basic scaffold. For 2.00 m bay lengths, install the Entry Platform EAW 200, EAW-2 200, EAC 200 or EAA 200 and Ladder UAF.



- For system width 100, a front-mounted stair tower must be fitted.
- Internal access using access decks is possible up to Load Class 3 (LC3).
- When not in use, the access hatches must remain closed!



Warning

Open access hatches pose a risk of falling.

- ⇒ Arrange the access openings alternately!



Caution!

Body parts can become trapped by self-closing access hatches.

- ⇒ The self-closing hatch should be firmly held during use!
- ⇒ Take into consideration any other persons waiting to use the hatch!

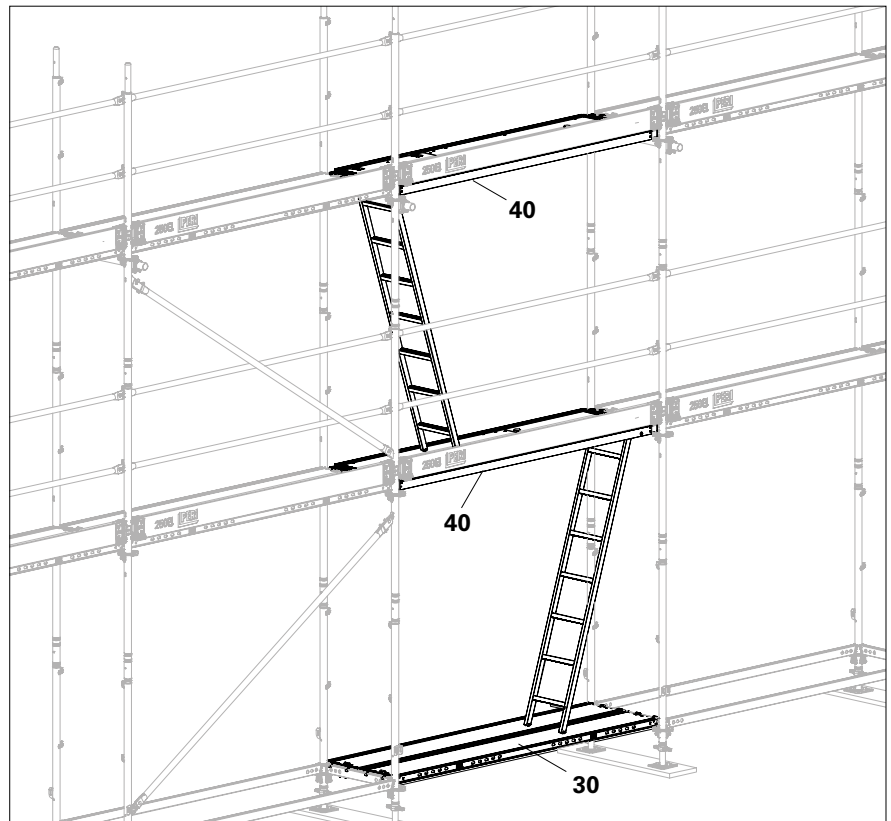

Fig. B8.11

Assembly

1. Fit Decks (30) onto the bottom level as a basis for the first ladder.
 2. In the following scaffold levels in this bay, install an access deck (40) instead of the deck.
- Access deck is installed.
(Fig. B8.12)



For deck variants, see Section "A4 System components: Deck" on page 34.

Components

-
- | | |
|-----------|-------------------|
| 30 | Steel Deck EDS |
| 40 | Access Deck EAW-L |
-

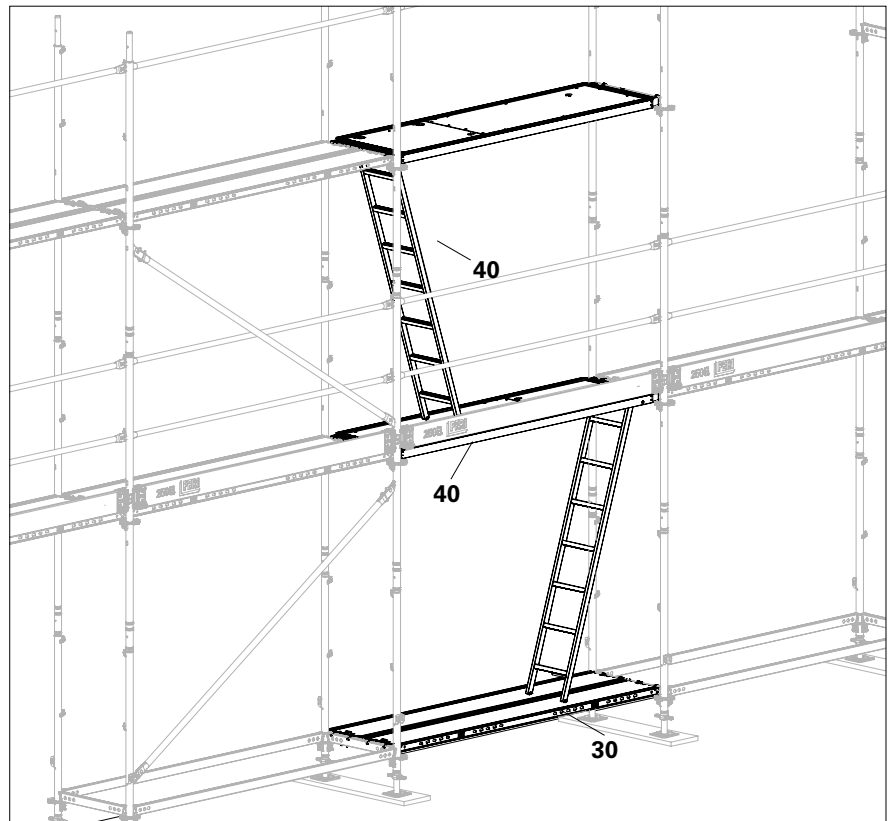

Fig. B8.12

General



- Comply with the prescribed assembly sequences!
- During modification work, the scaffold must be cordoned off to prevent any access!
- Anchor the scaffold section in the area of the opening on the left and right as an independent scaffold section at right angles and parallel to the facade.

Installing and removing scaffold bays

The integrated lift lock allows individual decks to be removed and refitted. This means that:

- individual bays can be opened or
- gaps that were necessary during erection can be closed later.

Opening the scaffold bay

From the scaffold bay to be dismantled:

1. Fit a Guardrail Coupling EPR (**58**) onto both Easy standards on the left and right of the planned opening. Fit the guardrail hooks facing outwards, at the same height as the guardrail hooks on the inside.
2. Attach temporary Guardrail Post EPG outside on the Guardrail Couplers EPR.
3. An End Guardrail EPF (**54**) must be installed on the side where the fitting order of the guardrail posts needs to be changed.

(Fig. B9.01)

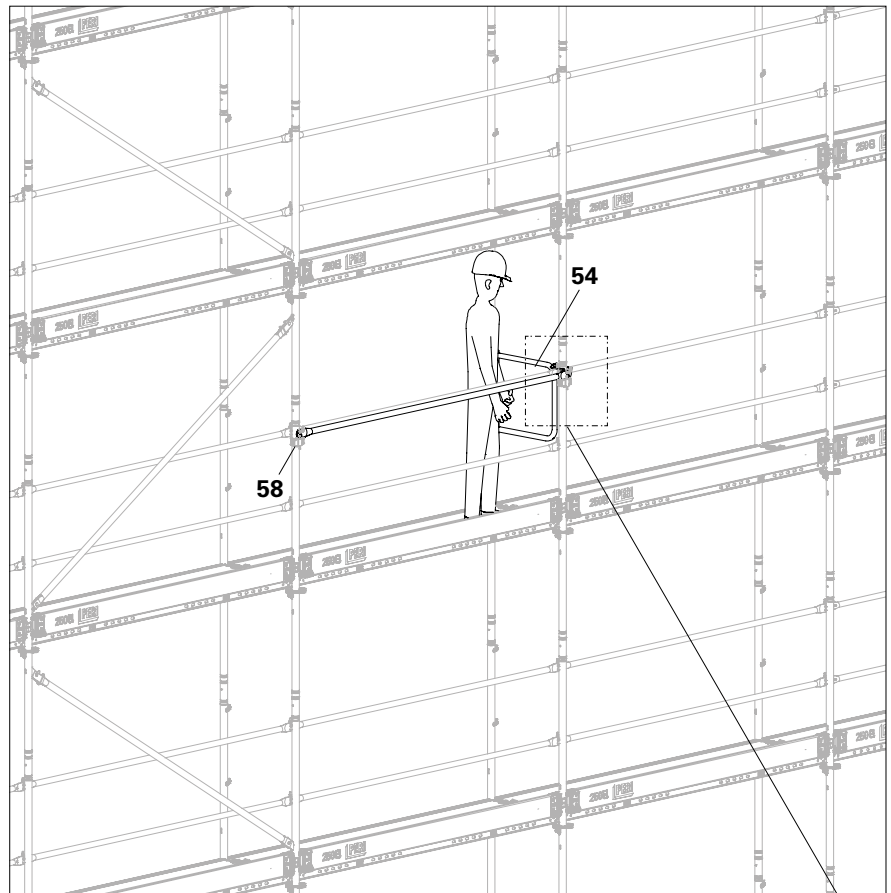
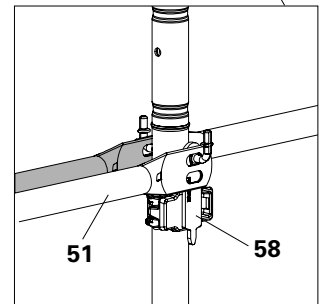

Fig. B9.01



4. Change the fitting order of the guardrails (51a, 51b) so that the guardrail post (**51a**) to be dismantled is hanging freely. (Fig. B9.01a)
5. Dismantle the temporary guardrail post (**51**) and guardrail couplings again.
6. Proceed in the same way with the intermediate guardrail.



- The side on which the guardrail posts have to be re-positioned depends on the assembly direction. The other guardrail side remains unchanged. (Fig. B9.01b)
- To remove/rehang, grasp the guardrail post in the middle, pull it towards you and turn it up as far as the horizontal of the connection piece. If necessary, turn it back slightly and then up again.



Leave guardrail couplings fitted if scaffold bay is to be closed again.

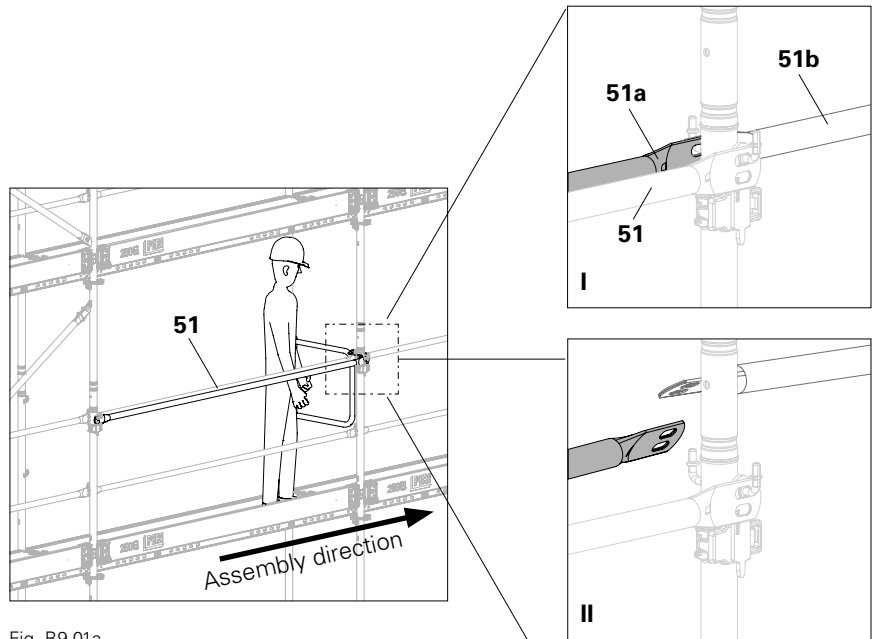

Fig. B9.01a

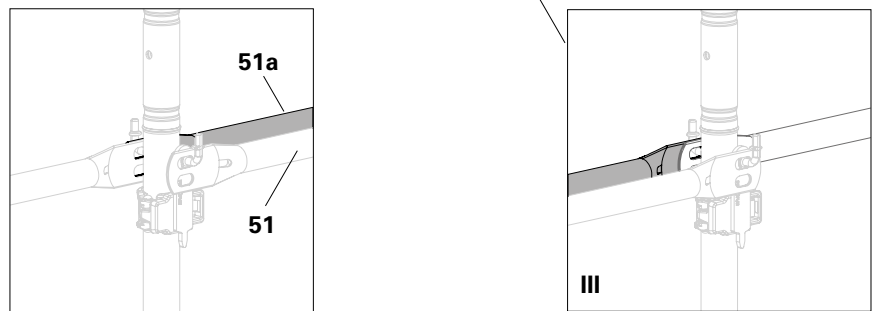

Fig. B9.01b

- From the adjacent scaffold bay:
7. Block off the scaffold bay with a second end guardrail (**54**).
 8. From a safe position, disconnect Guardrail Post EPG (**51a**) and the intermediate guardrail from the guardrail hooks and remove the toe board. (Fig. B9.01c)

Components

- | | |
|-----------|------------------------|
| 51 | Guardrail Post EPG |
| 54 | End Guardrail EPF 67 |
| 58 | Guardrail Coupling EPR |

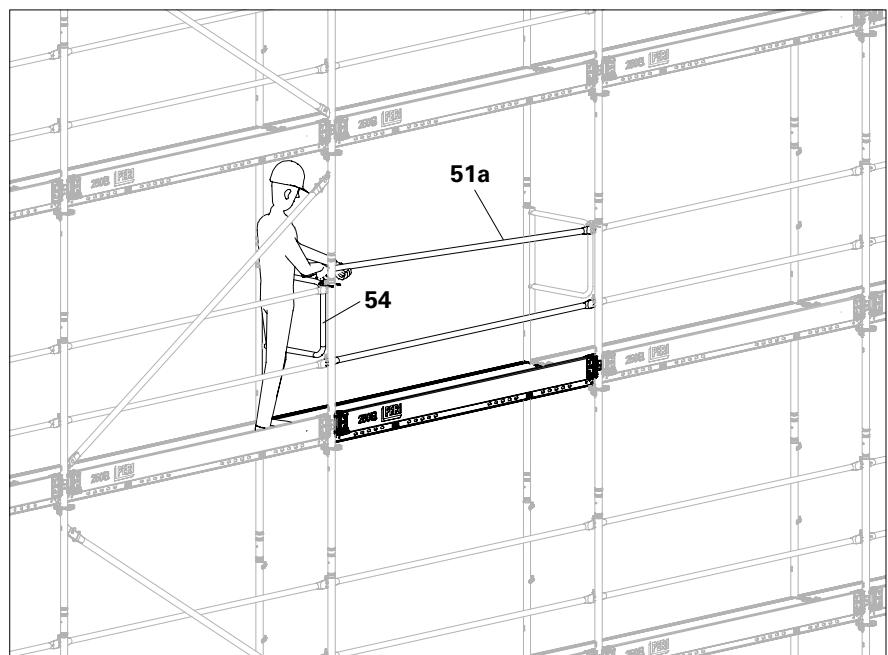

Fig. B9.01c

From the level immediately below:

9. Remove the decks.
 10. Install Toe Boards UPF (**56**).
- The scaffold bay is now dismantled.
(Fig. B9.01d)

Provide suitable access to cut scaffold level.

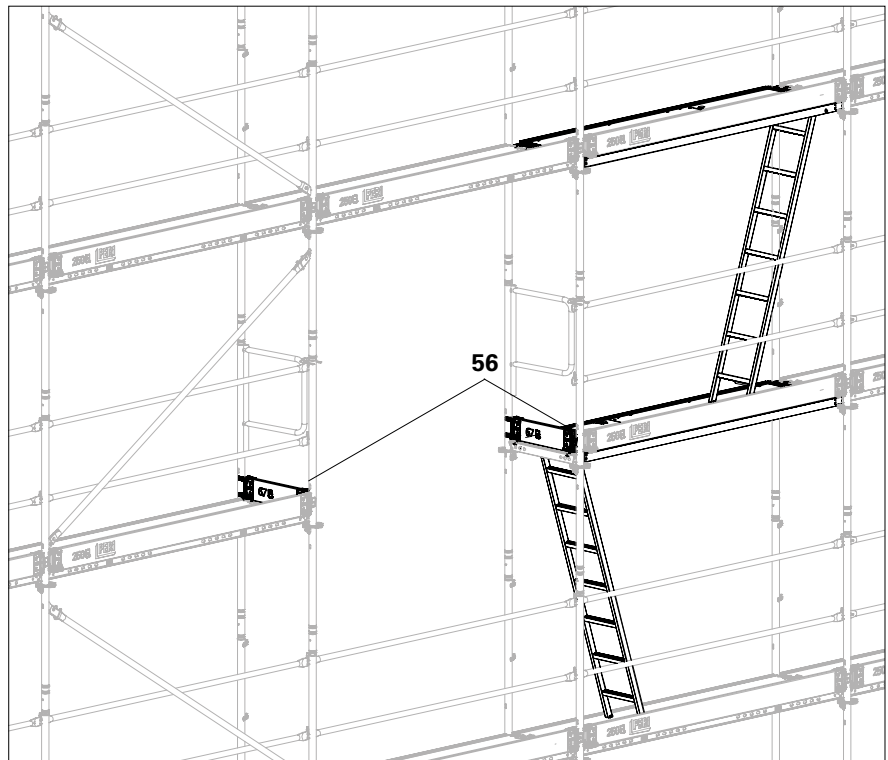

Fig. B9.01d

Closing the scaffold bay

From the level immediately below:

1. Remove the Toe Boards UPF.
2. Install the decks (**30**).

Components

-
- | | |
|-----------|------------------------|
| 30 | Steel Deck EDS |
| 51 | Guardrail Post EPG |
| 52 | End Guardrail EPF |
| 56 | Toe Board UPF |
| 58 | Guardrail Coupling EPR |
-

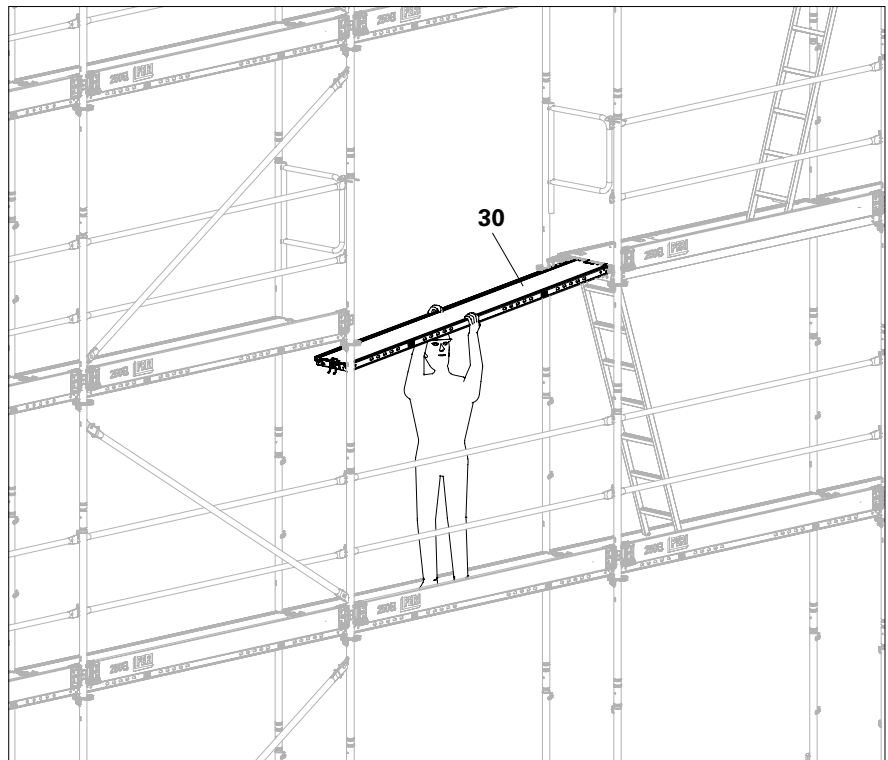

Fig. B9.02

- From the adjacent scaffold bay:
 3. Attach the Guardrail EPG and intermediate guardrail post to the guardrail hooks and fit the toe board.
 4. Remove the first End Guardrail EPF (52). (Fig. B9.02a)
- From the scaffold bay to be closed:
 5. Fit a Guardrail Coupling EPR (58) onto both Easy standards on the left and right of the opening. Fit the guardrail hooks onto the outside, at the same height as the guardrail hooks on the inside (Fig. B9.02c).
 6. Attach a temporary additional Guardrail Post EPG (51) to the outside of the Guardrail Couplings EPR.
 7. Make suitable amendments to the fitting order of the guardrail posts. (Fig. B9.02b)

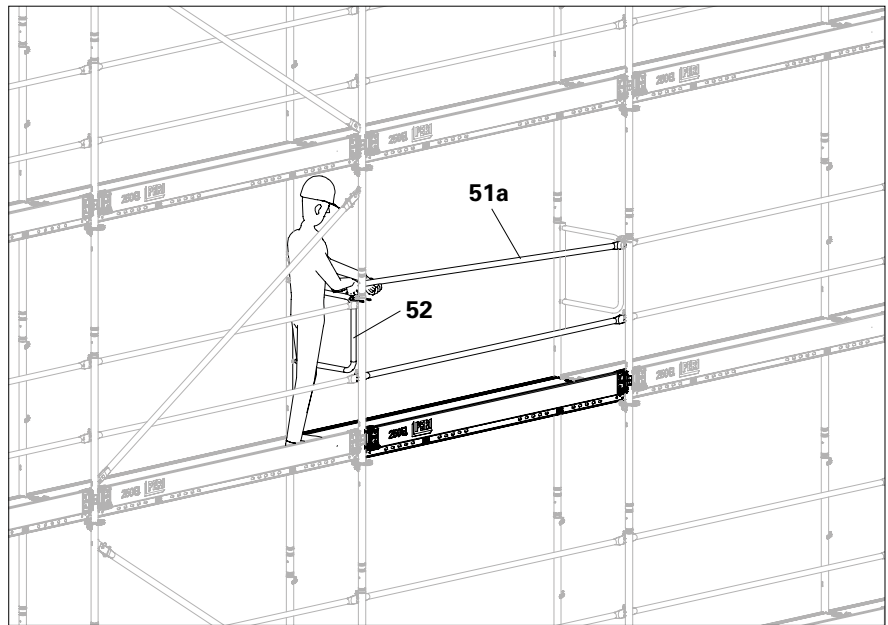

Fig. B9.02a



- To remove/rehang, grasp the guardrail post in the middle, pull it towards you and turn it up as far as the horizontal of the connection piece. If necessary, turn it back slightly and then up again.
 - Install the guardrail post in the same direction as was used for the scaffold assembly, namely in a "fish scale arrangement". Otherwise it cannot be removed correctly during dismantling operations.
8. Remove the temporary guardrail post (51) and guardrail couplings (58).
 9. Proceed in the same way with the intermediate guardrail.
 10. Remove the second end guardrail (52a).
- The scaffold bay is now closed.

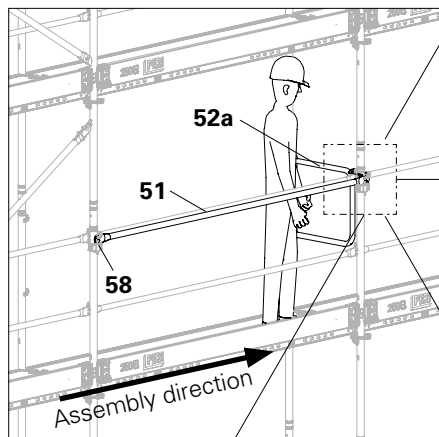

Fig. B9.02b

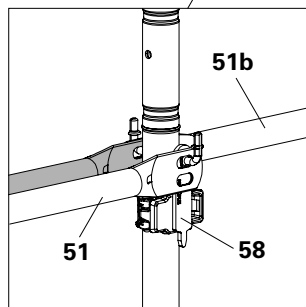
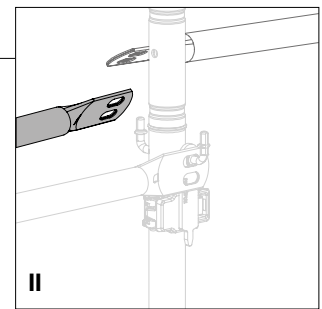
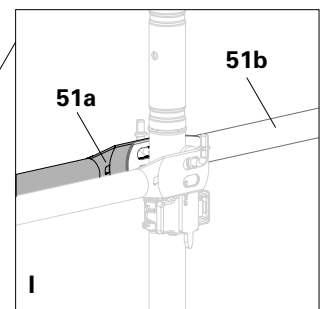

Fig. B9.02c



Closing scaffold areas

Any building around an obstruction (e.g. with a console bracket scaffold for formwork materials) that is necessary due to the construction process can be subsequently closed using PERI UP Easy.

(Fig. B9.03)

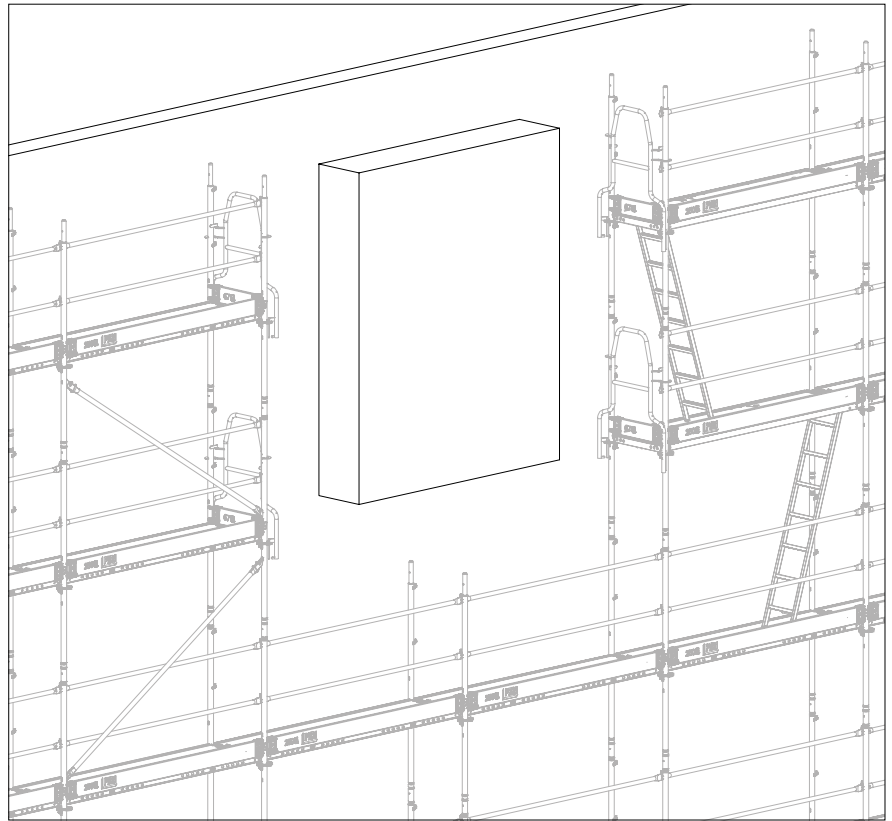

Fig. B9.03

Assembly

1. Install 2x Easy Standards EVM (22) and Horizontal Ledger UH-2 67 (98) with Guardrail Post EPG (51) from the level below.
 2. Install the decks (30).
- (Fig. B9.04)

Components

22	Easy Standard EVM 200
30	Steel Deck EDS
51	Guardrail Post EPG
52	Advance End Guardrail UPA 67
56	Toe Board UPF
98	Horizontal Ledger UH-2 67

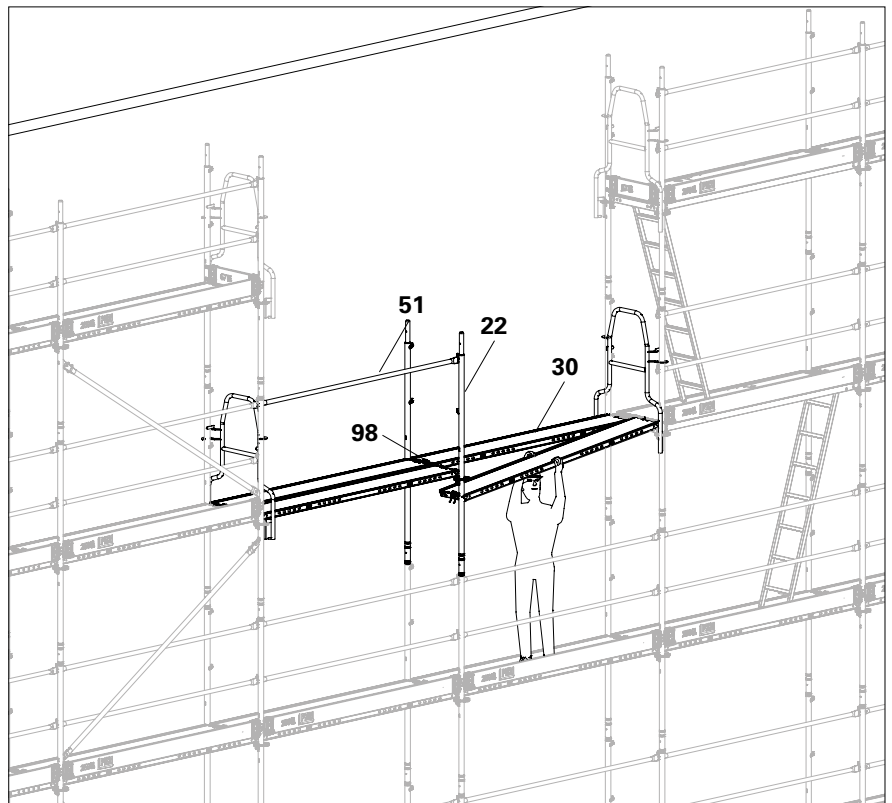

Fig. B9.04

3. From a safe position, install the second Guardrail Post EPG (**51**).
 4. Remove End Guardrails in Advance UPA (**52**).
- (Fig. B9.05)



Install the guardrail post in the same direction as was used for the scaffold assembly, namely in a "fish scale arrangement". Otherwise it cannot be removed correctly during dismantling operations, see Section "Installing and removing scaffold bays" on page 92 ff.

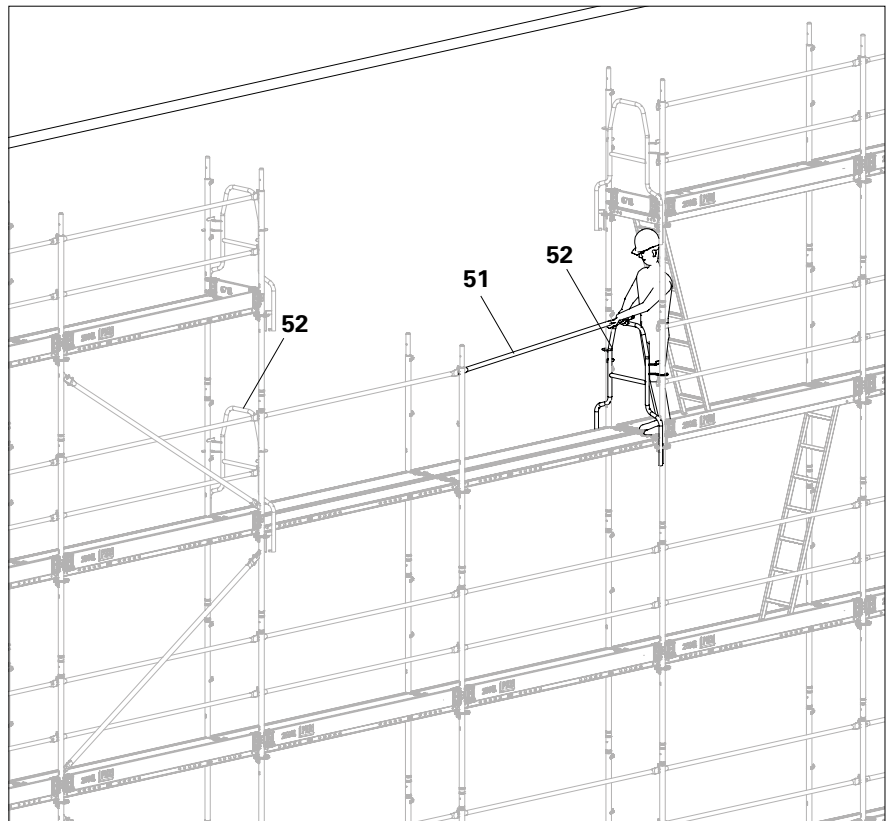

Fig. B9.05

5. Complete the lateral protection with intermediate guardrails (**51a**) and Toe Boards UPF (**56**), see Section "B4 Other levels" on page 64.
 6. Repeat work steps 1 – 5 until all levels are closed.
- The scaffold area is closed.
(Fig. B9.06)

Components

- | | |
|-----------|------------------------------|
| 51 | Guardrail Post EPG |
| 52 | Advance End Guardrail UPA 67 |
| 56 | Toe Board UPF |

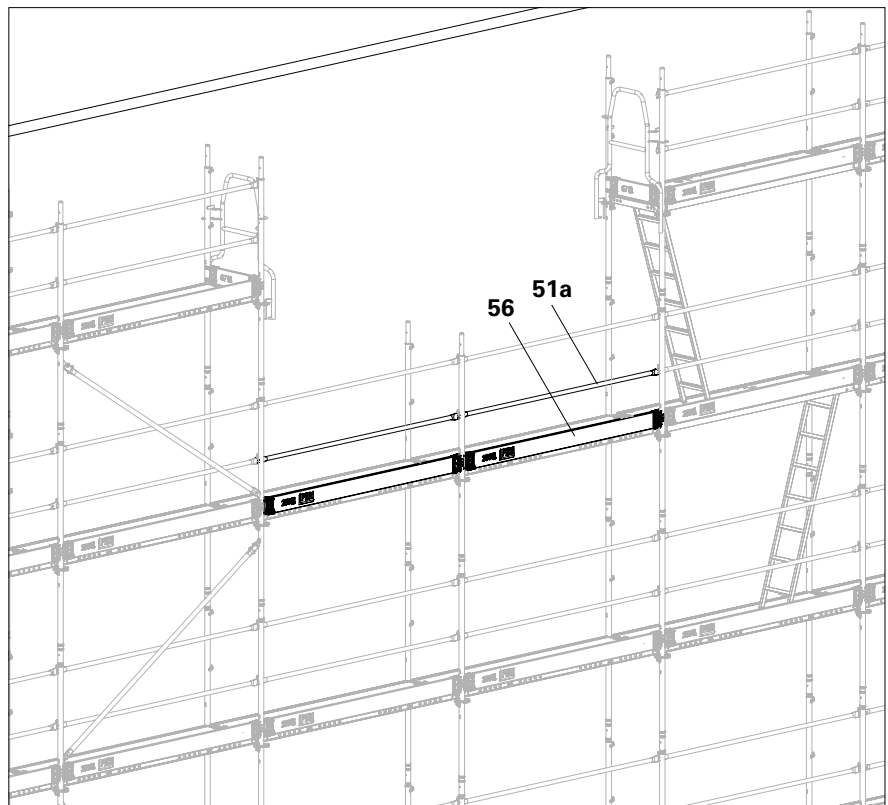

Fig. B9.06

Nets/tarpaulin



Note

Stability compromised!

⇒ When cladding with nets or tarpaulin, pay particular attention to the increased number of ties.

The number of ties is largely determined by the wind permeability of the netting and ratio of openings on the facade, see Section Tie pattern.



Likewise, the front side of the facade scaffold must be closed up to the wall.

Cladding with nets

The standard configurations shown in the "Tie pattern" sections were determined with coefficients for the netting of $cf \perp \leq 0.6$ and $cf \parallel \leq 0.2$.

The nets are to be fastened to the scaffold standards according to the manufacturer's instructions. (Fig. B10.01 + B10.02)

Cladding with tarpaulins

The tarpaulins are to be fastened to the scaffold standards according to the manufacturer's instructions (not shown).

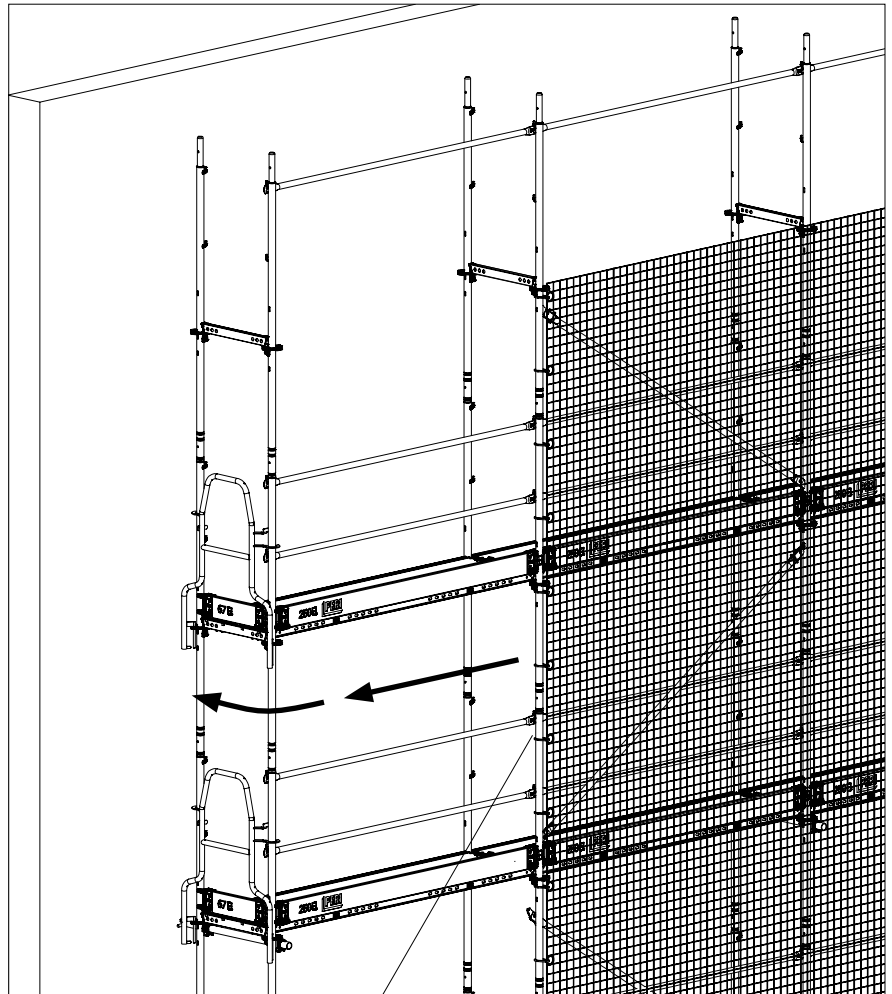

Fig. B10.01

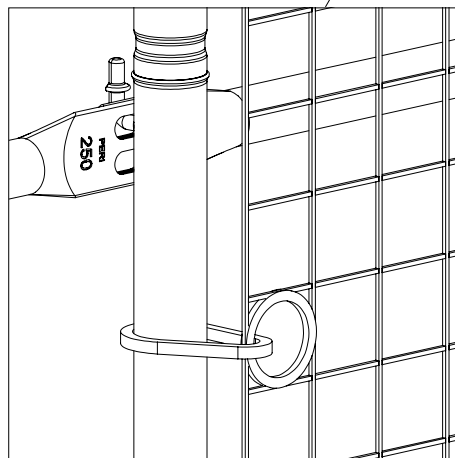

Fig. B10.02

Compatible in 3 dimensions

PERI UP Easy frame variant and PERI UP Flex

Due to coordinated system and component dimensions, the PERI UP Easy facade scaffold can be combined with the PERI UP Flex as a standard or frame variant.

Thus, for example, an Easy Frame EVF can be replaced by a Standard UVR-2 50, UVR-2 200 and a Horizontal Ledger UH-2.

The integrated protection against lifting facilitates a smooth transition from the modular to the frame variants without additional parts. This means that any combination is possible, both in the vertical and horizontal directions.

If areas of a PERI UP Easy scaffold are erected using PERI UP Flex scaffolding components, then the following applies for assembly, modification and dismantling operations:

- Instructions for Assembly and Use for PERI UP Flex for these areas,
- the Instructions for Assembly and Use provided here for the areas of the PERI UP Easy scaffolding.

Fit the Horizontal Ledger UH-2 67 as support for the decks.



Possible applications in conjunction with Standards UVR-2:

- Height compensation.
- Building around obstacles, e.g. bay windows.
- Attaching console brackets in 50-cm height increments.
- Attaching material platforms.
- Compatibility with PERI UP Flex staircases.

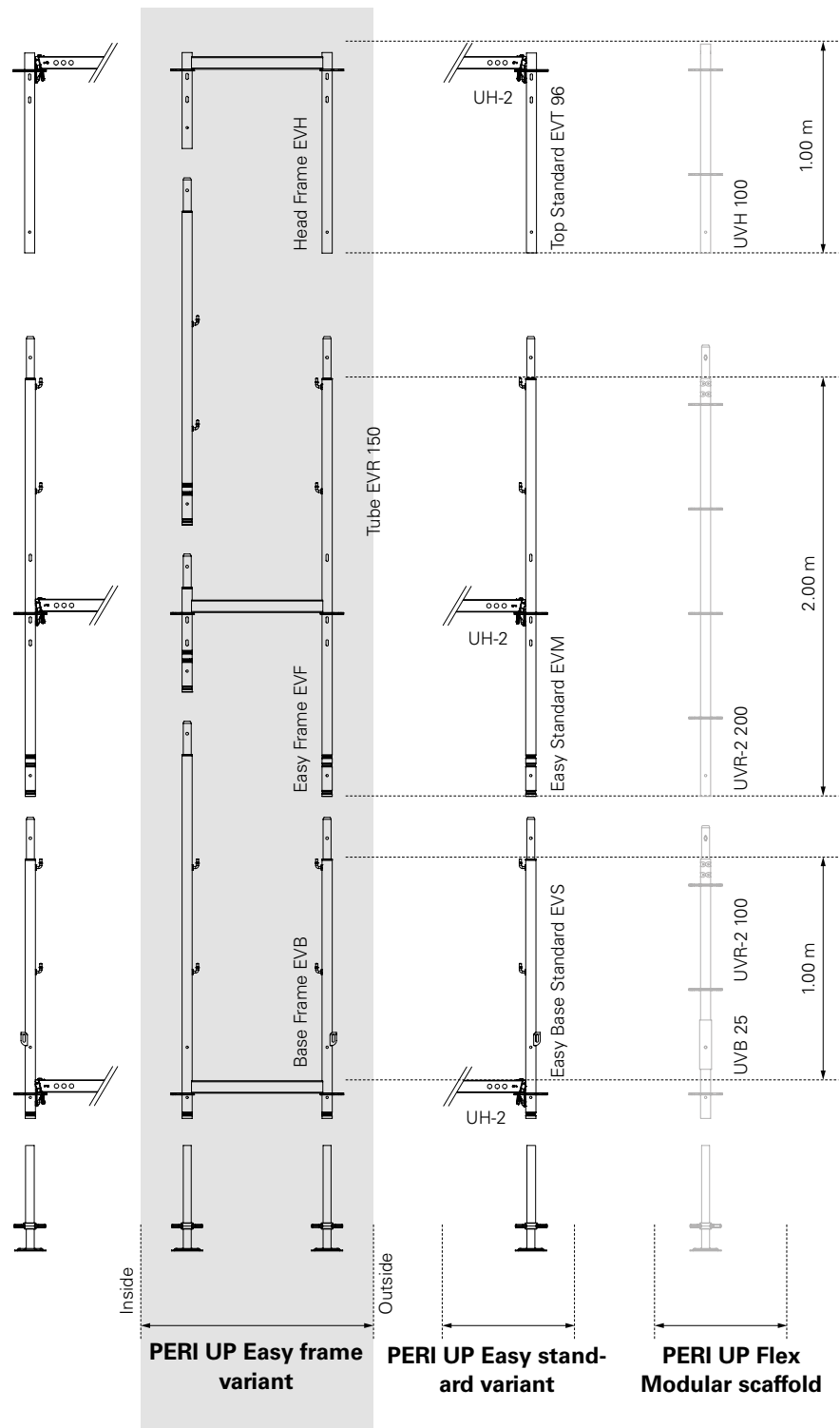

Fig. C1.01

Side-by-side combination

The PERI UP Flex modular scaffolding is connected to the PERI UP Easy facade scaffold using Steel Decks EDS (30) or Combi Decks EDW and Guardrail Posts EPG (51).

The Flex area is erected as stand-alone scaffold according to the Instructions for Assembly and Use for PERI UP Flex. (Fig. C1.02)

Assembly

1. Insert Guardrail Holder EPW (59) into the rosettes of the Standards UVR-2 (82). Guardrail hooks must point inwards towards the deck. Secure the wedges.
2. Attach Guardrail Posts EPG and intermediate guardrails to the guardrail hooks.
3. Fit the steel decks onto the Horizontal Ledgers UH-2 67.
4. Fit Toe Board UPF. (Fig. C1.02 + C1.03)

Components

- | | |
|-----------|----------------------|
| 30 | Steel Deck EDS |
| 51 | Guardrail Post EPG |
| 59 | Guardrail Holder EPW |
| 82 | Standard UVR-2 |

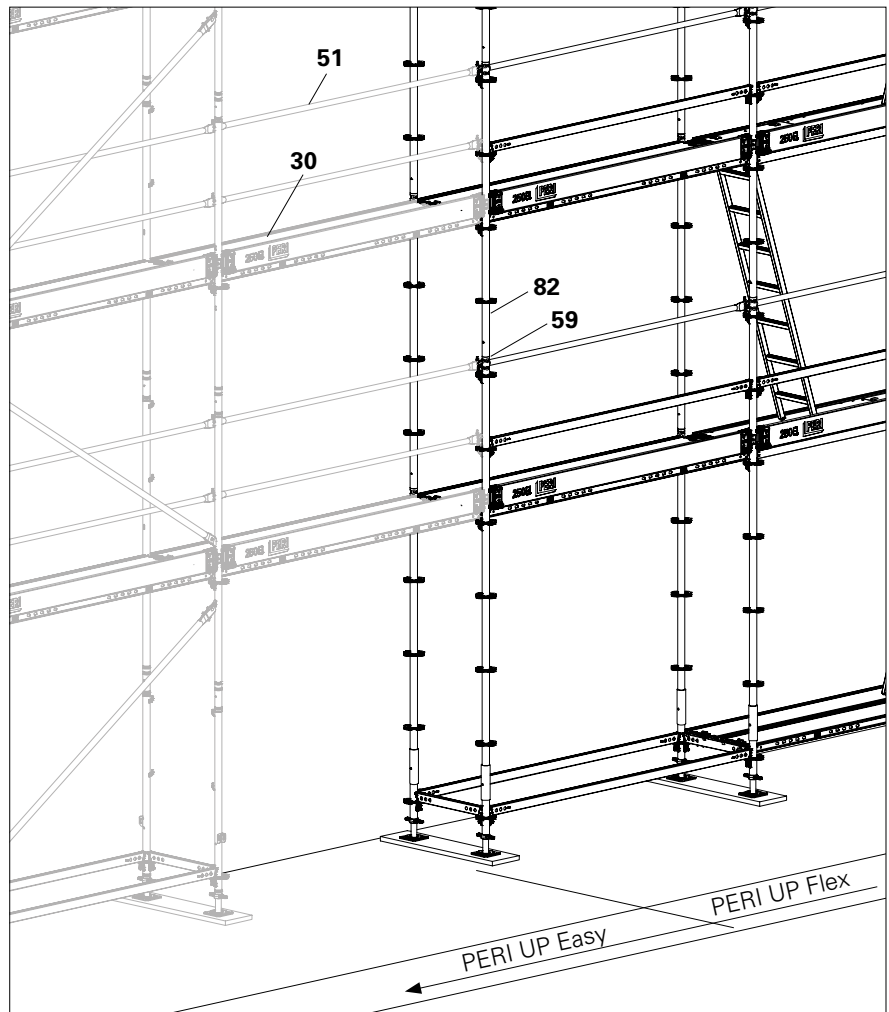

Fig. C1.02

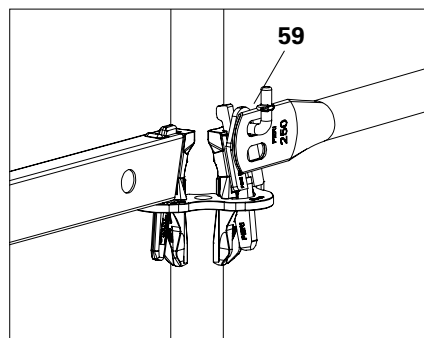

Fig. C1.03

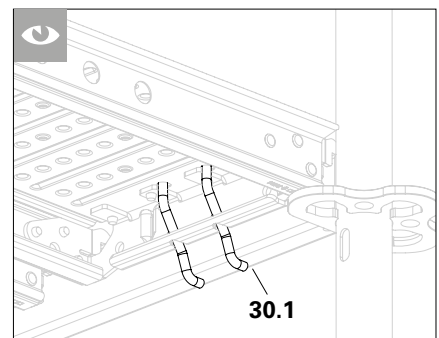

Fig. C1.04

Have both lift locks (30.1) dropped beneath the crossbars and horizontal ledgers? (Fig. C1.04)

If not, lift the deck slightly and let it drop into position or operate the lift lock manually.

One above the other combination



A system change can take place at any height.

PERI UP Flex on PERI UP Easy

1. Fit Standards UVR-2 200 (**83**) onto the inner and outer sides of the Easy Standards EVM (**22**).
2. Fit one Node Brace UBK (**89**) at the transition to the PERI UP Flex. Fit one side (**89.1**) into the rosette of the Easy Standard (**22**) beneath the last deck level of the Easy scaffold (Fig. C1.05b). Fit the other side (**89.2**) into the rosette of the Standard UVR-2 200 (**83**) beneath the first deck level of the Flex scaffolding. (Fig. C1.05a)
3. Continue erecting according to the Instructions for Assembly and Use for PERI UP Flex.
4. Create lateral protection for the PERI UP Flex consisting of Guardrail Post EPG (**51**) and Horizontal Ledger UH-2 (**94**).
5. Fit Toe Boards UPF. (Fig. C1.05)

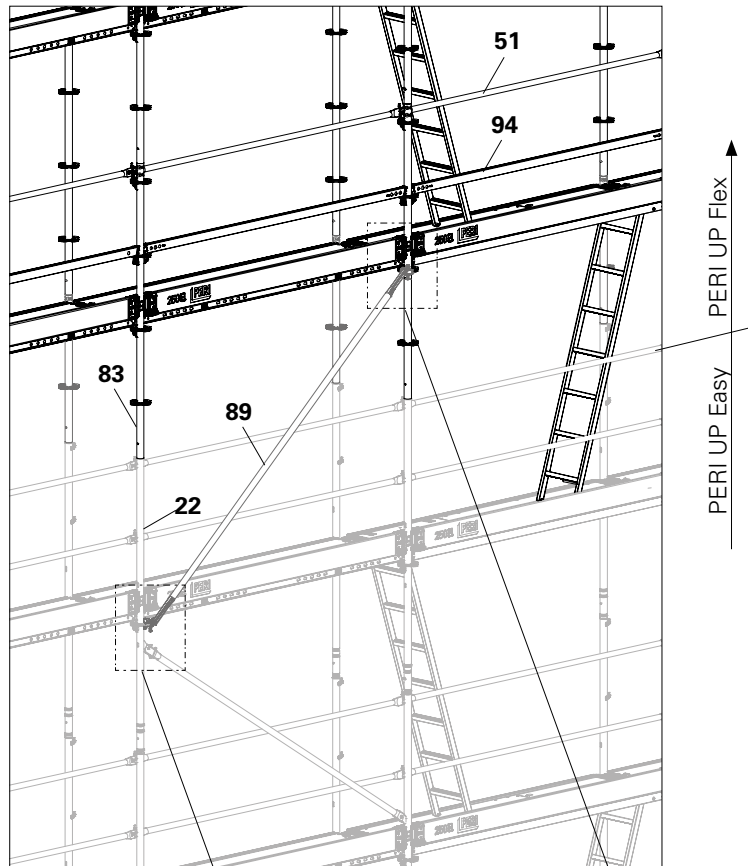

Fig. C1.05

Components

22	Easy Standard EVM 200
51	Guardrail Post EPG
59	Guardrail Holder EPW
83	Standard UVR-2 200
89	Node Brace UBK
94	Horizontal Ledger UH-2



The guardrail can also be mounted in advance using Standards UVR-2 and Guardrail Holders EPW.

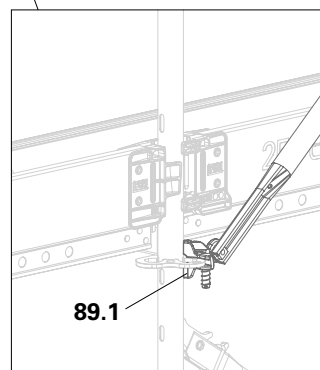

Fig. C1.05b

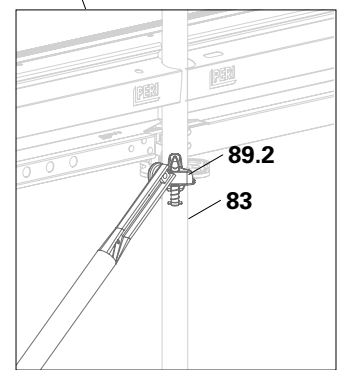

Fig. C1.05a

PERI UP Easy on PERI UP Flex

1. End the flex scaffold at the inner and outer legs 1 m above deck level at the transition to the Easy scaffold.
2. Install Horizontal Ledgers UH-2 (94) or Guardrail Holders EPW (59) and Guardrail Post EPG (51) as guardrail posts.
3. Fit Easy Standards EVM 200 (22) with Guardrail Post in Advance EPG (51) onto the Standards UVR-2 (83).
4. Continue erecting according to the Instructions for Assembly and Use for PERI UP Easy.

(Fig. C1.06)

■ In bays with Face Braces EBF

1. Form the outer leg of the Flex scaffold at the transition to the Easy scaffold from two Standards UVR-2 100 (85). The pin hole of the standards is used for fitting the Brace Adapter EBA (24).
2. Fit the Brace Adapter EBA (24). Insert the twist protection into the hole of the Standards UVR.
3. Fit Face Brace EBF (20).

(Fig. C1.06a – C1.06c)

Alternatively:

Fit a Node Brace UBK, see previous page.

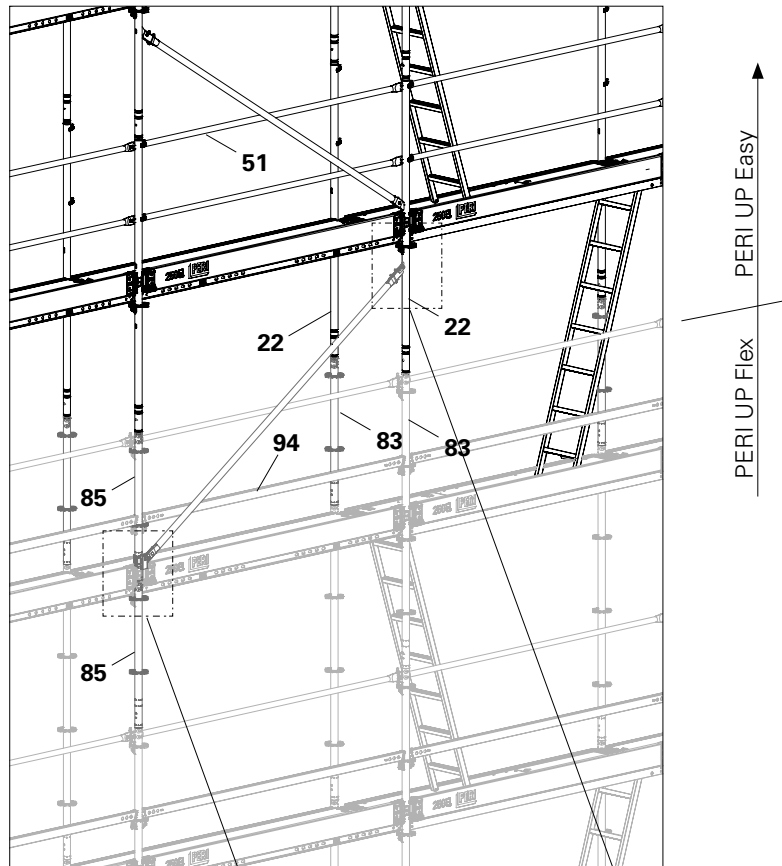

Fig. C1.06

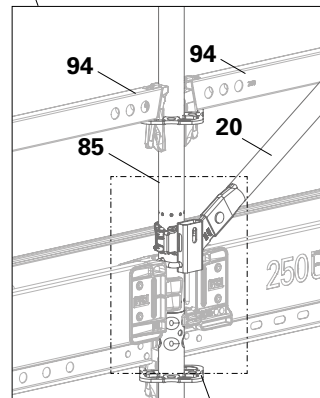

Fig. C1.06a

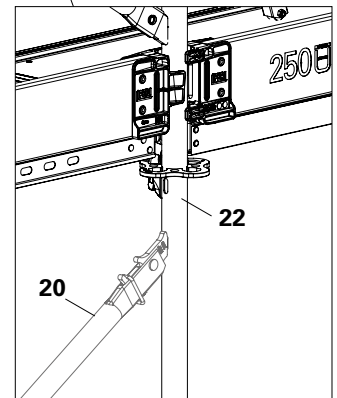

Fig. C1.06b

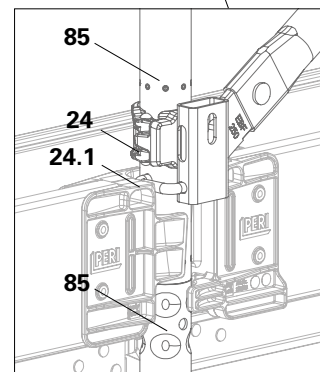

Fig. C1.06c

General



- For the permissible Load Classes, see Section "A6 System components: Console brackets" on page 40.
- Additional anchoring is required to mount the console brackets, see the Section Tie pattern.

Internal console brackets

The following supports can be installed simultaneously on all scaffold levels as internal console brackets. Steel Decks EDS (30) are installed as decks.

The following supports are used:

- Support UC 25,
- Support UC 33 (61),
- Support UCS 33 (60).

Furthermore, the following may be used on all scaffold levels:

- Console Brackets ECM 33 (62),
- Console Brackets UCB 25 (with Decks UDG)

All supports and console brackets are attached to rosettes of the Easy Standards EVM (22) or to the Top Standards EVT (17) on the top scaffold level.

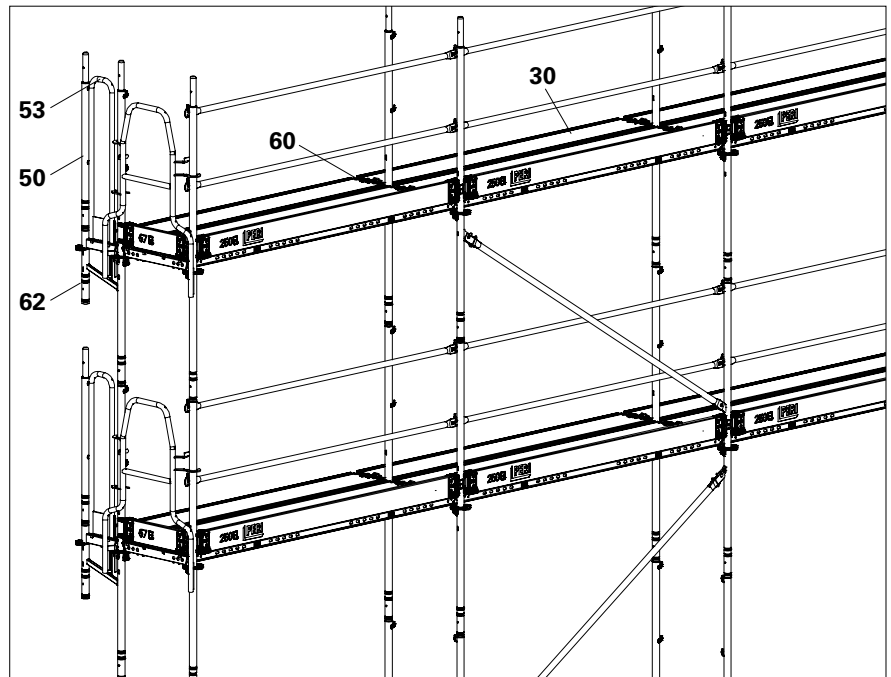

Fig. D1.01

Assembly

1. Fit Console Bracket ECM 33 (**62**) onto the edge frame column with pre-assembled Guardrail Post EVP (**50**). (Fig. D1.02 + D1.02a)
 2. Fit Support UC 25, UC 33, or UCS 33 (**60**) onto the middle frame. (Fig. D1.03)
 3. Insert Steel Decks EDS (**30**).
 4. Fit the End Guardrail EPF (**53**). (Fig. D1.02)
- The console brackets are now installed.

Edge frame column with Console Bracket ECM 33

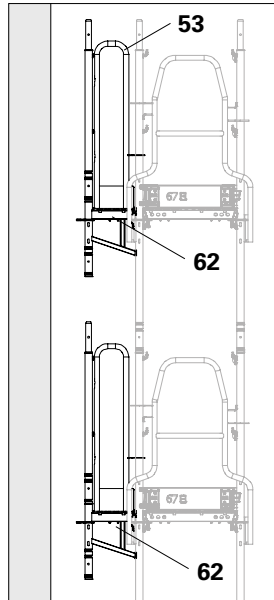

Fig. D1.02

Middle frame column with Support UCS 33

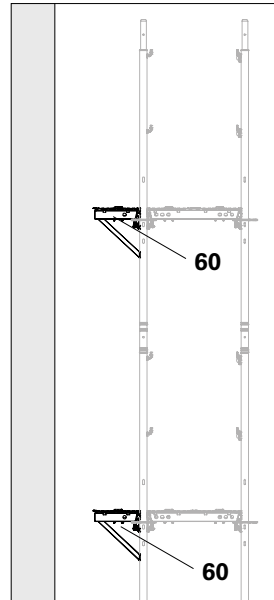

Fig. D1.03

Middle frame column with Console Bracket ECM 33 and guardrail post

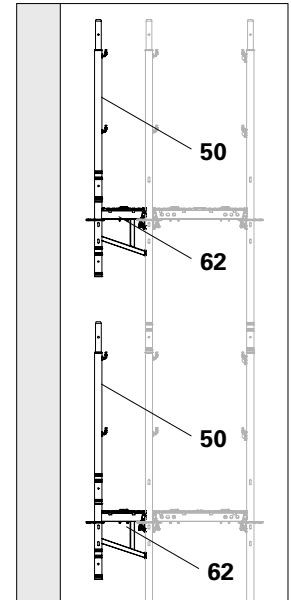

Fig. D1.03a



To assemble an inner guardrail (**51a**), fit Console Brackets ECM (**62**) with guardrail posts instead of Supports UCS 33 (**60**). (Fig. D1.03a + D1.03b)

Components

- 30** Steel Deck EDS
- 50** Guardrail Post EVP
- 51** Guardrail Post EPG
- 53** End Guardrail EPF 33
- 60** Support UCS 33
- 61** Support UC 33
- 62** Console Bracket ECM 33

Edge frame column Middle frame column Alternatively: with inner guardrail (**51a**).

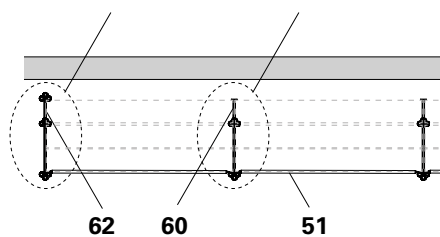

Fig. D1.02a

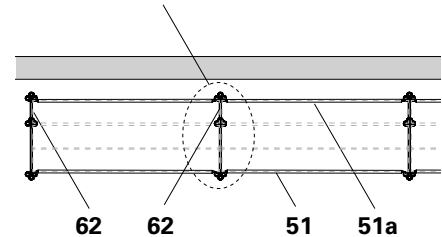

Fig. D1.03b

Fitting internal console brackets onto the PERI UP Easy 100 (standard variant)

Only Console Brackets ECM 33 (**62**) are permitted for use as internal console brackets in scaffold levels 1 to 6. Bay length max. 2.50 m. See Section "Basic variant 2a/LC4" on page 234.

The internal console brackets must be supported in pairs by the tube EVR 150 (**18**):

- Level 6 on level 5,
- Level 4 on level 3,
- Level 2 on level 1.

Supports UC 25, UC 33 or UCS 33 can also be installed in the scaffold levels situated above.

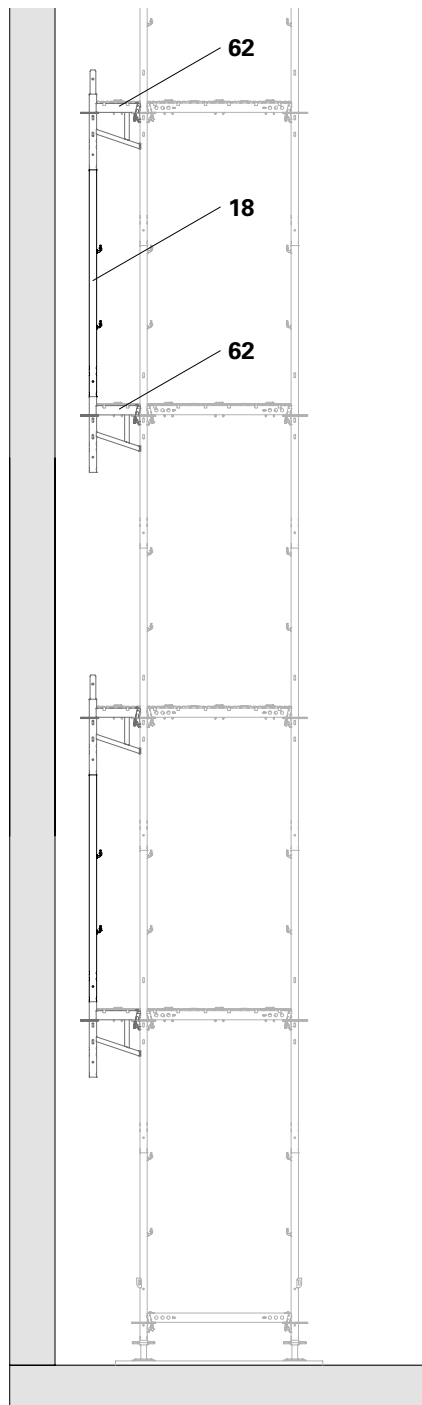

Fig. D1.04

Internal console brackets with additional support

Two console brackets connected one behind the other can be installed simultaneously on the inner side of the scaffolding at all scaffold levels.

A minimum scaffold width of 0.9 m and additional, removable internal console brackets are recommended for ETICS assembly. Local laws and regulations must be observed.



Console brackets connected one behind the other are not covered by the standard configuration. Separate static proof for the stability is required here.

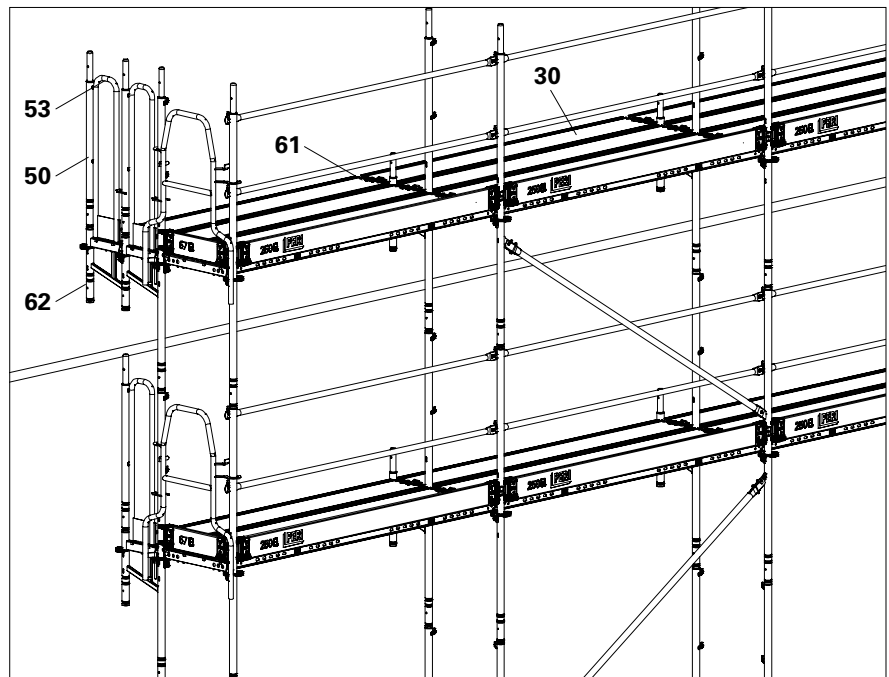

Fig. D1.05

Assembly

1. Fit the first row of Console Brackets ECM 33 (**62**), see internal console brackets.
As a result, the scaffold width is 1.0 m.
2. Fit two rows of Console Brackets ECM 33 or Supports UC 33 into the $\frac{3}{4}$ rosette of the Console Bracket ECM as removable internal console brackets.
 - Fit Console Bracket ECM 33 (**62**) onto the edge frame columns with pre-assembled Guardrail Post EVP (**50**) and End Guardrail EPF (**53**). (Fig. D1.06 + D1.06a)
 - Fit Support UC 33 (**61**) onto the middle bays. (Fig. D1.06a + D1.07)
3. Install decks.
→ The console brackets are now installed.

Alternatively:

Fit Supports UC 25 and Console Brackets UCB 25 with Decks UDG in 25 cm widths.

Edge frame column with additional Console Bracket ECM 33/UCB 25.

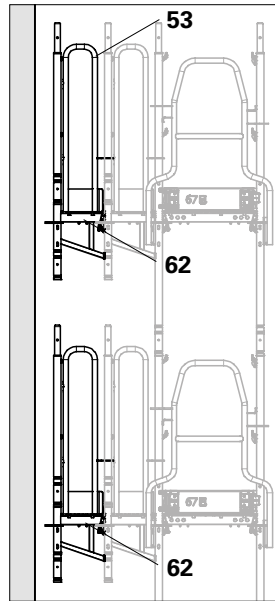

Fig. D1.06

Middle frame column with additional Support UC 33/25.

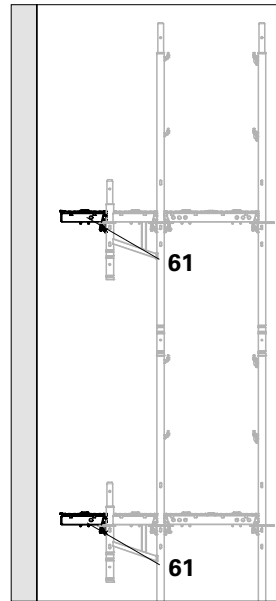

Fig. D1.07

Middle frame column with additional Console Bracket ECM 33/UCB 25 and guardrail post.

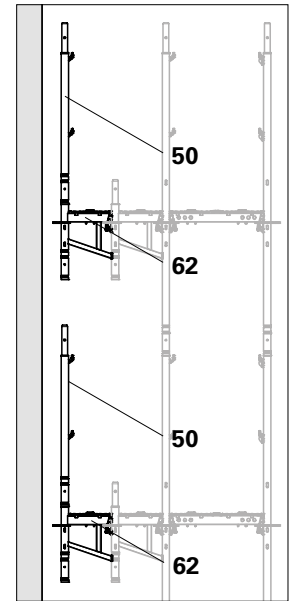

Fig. D1.07a



To assemble an inner guardrail (**51a**), fit Console Brackets ECM (**62**) with guardrail posts instead of Supports UC 33 (**61**). (Fig. D1.07a + D1.07b)

Edge frame column Middle frame column Alternatively: with inner guardrail (**51a**).

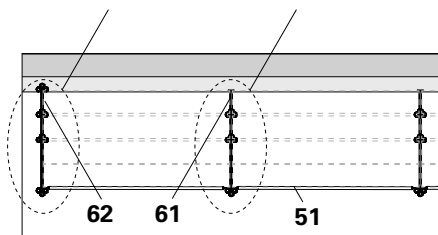

Fig. D1.06a

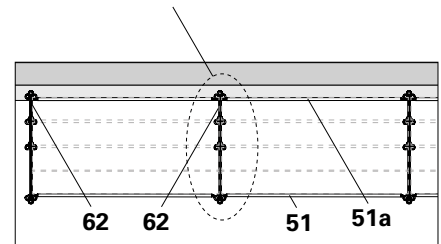

Fig. D1.07b

Components

- | | |
|-----------|------------------------|
| 30 | Steel Deck EDS |
| 50 | Guardrail Post EVP |
| 51 | Guardrail Post EPG |
| 53 | End Guardrail EPF 33 |
| 61 | Support UC 33 |
| 62 | Console Bracket ECM 33 |

Dismantling of internal console brackets

To install thermal insulation from below, the internal console bracket must be dismantled gradually.



Warning

Dismantling the internal console brackets may result in an impermissible large distance to the building. A resulting fall can cause serious injury.
 ⇒ Install inner guardrails in advance.

Dismantling

1. Fit the inner guardrails, see Section "Advanced guardrail" on page 25.
2. Dismantle End Guardrails EPF (53) and Guardrail Posts EVP (50) at the edge bays.
3. Remove the decks.
4. Dismantle Supports UC 33 (61) or Console Brackets ECM 33.

(Fig. D1.08 + D1.09)

Components

-
- | | |
|-----------|------------------------|
| 50 | Guardrail Post EVP |
| 53 | End Guardrail EPF 33 |
| 61 | Support UC 33 |
| 62 | Console Bracket ECM 33 |
-

Middle frame column

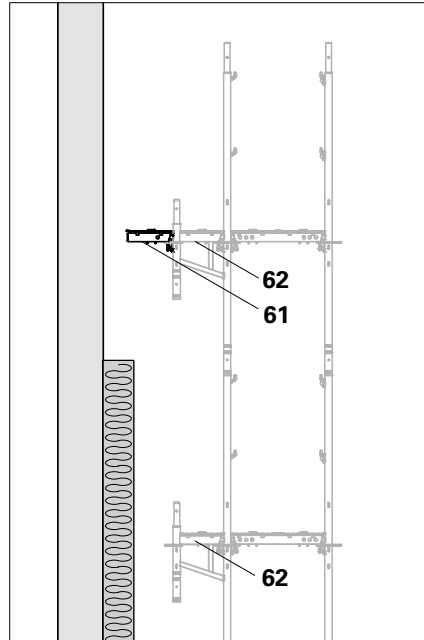

Fig. D1.08

Edge frame column

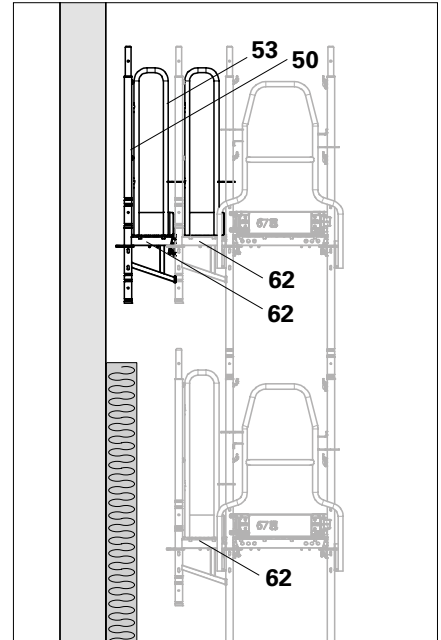

Fig. D1.09

Anchoring with ETICS

In accordance with standards DIN EN 12811-1 and DIN EN 12810-1, scaffolds must be designed to accommodate forces parallel to the facade as well.

The load-bearing capacity of eyebolts for forces parallel to the facade approaches zero as the shaft length increases.

The following measures are suitable for accommodating these forces:

- permanent anchoring
- ETICS special scaffold tie

With PERI UP Easy, additional measures are possible:

- structural scaffold bracing
- free-standing scaffold

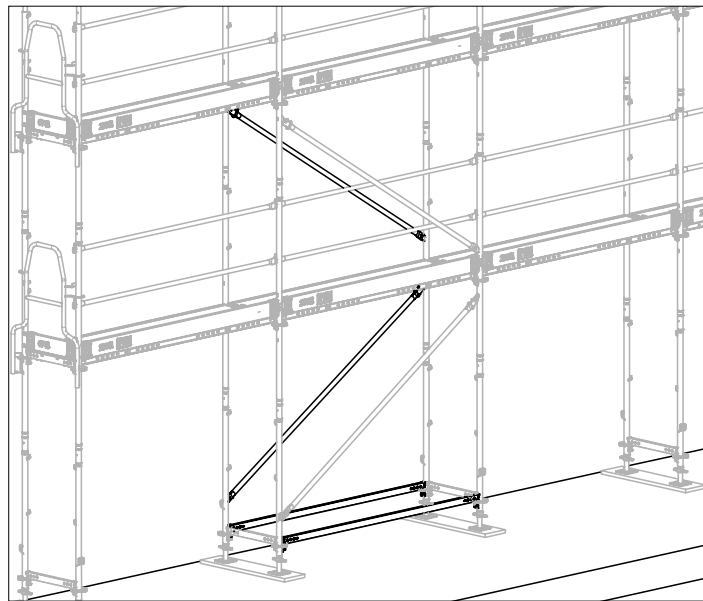

Fig. D1.10

Structural scaffold bracing

This can be effected, for example, by installing additional diagonals on the inside of the scaffolding. See Section "Internal braces" on page 39.

(Fig. D1.10)

Free-standing scaffold

Scaffolds that cannot be anchored require a larger erection surface and, if necessary, additional ballasting. See Section "Scaffolding support" on page 239. (Fig. D1.11)



For a structurally braced or free-standing scaffold, separate static proof of stability is required.

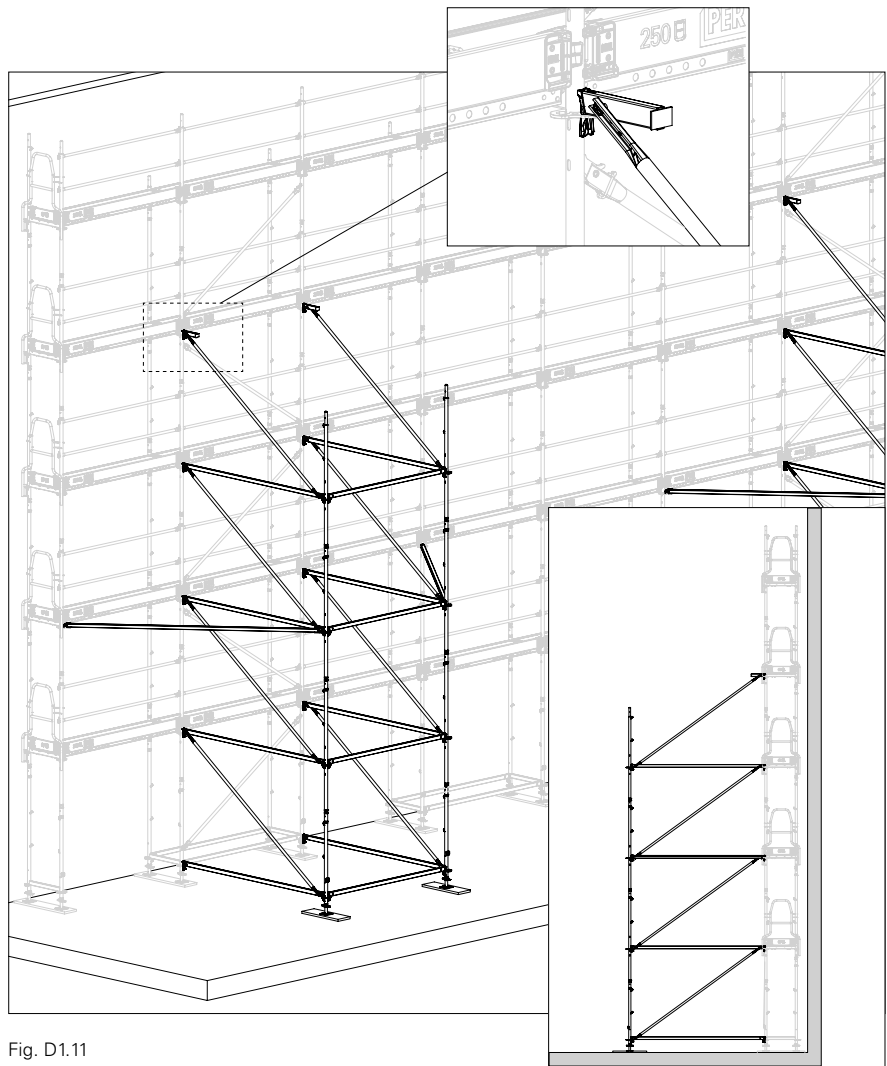

Fig. D1.11

External console brackets

Console brackets can be mounted as external console brackets on just one scaffold level of choice. Steel Decks EDS (30) are installed as decks.



Note additional anchoring, see Section Tie pattern.

The following console brackets are used:

- Console Bracket ECM 33 (62)
- Console Bracket ECM 67 (63)

For the permissible Load Classes, see Section "A6 System components: Console brackets" on page 40.

All console brackets are attached to rosettes of the Easy Standard (22) or to the Top Standard EVT 96 (17) on the top scaffold level.

Preparation

Assemble the top level of the basic scaffold with the advanced guardrail.

1. Assemble edge frame with Easy Standard 200 (22) and End Guardrail in Advance UPA 67 (52).
2. Outer leg of the middle frames with Top Standard EVT 96 (17), Spigot with Spacer Tube URE (68), Guardrail Post EVP (50) and Guardrail Post EPG (51).
3. Insert Steel Decks EDS (30) into the basic scaffold.

(Fig. D1.12)



For frame columns with diagonal ends above: insert the short spigot of the spacer tube (68) into the top standard. (Fig. D1.12a)

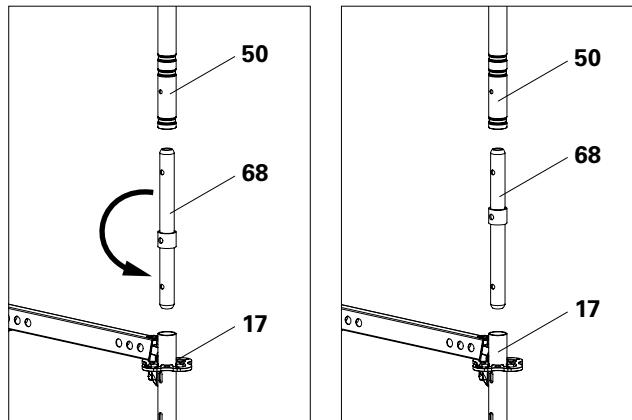

Fig. D1.12a

Fig. D1.12b

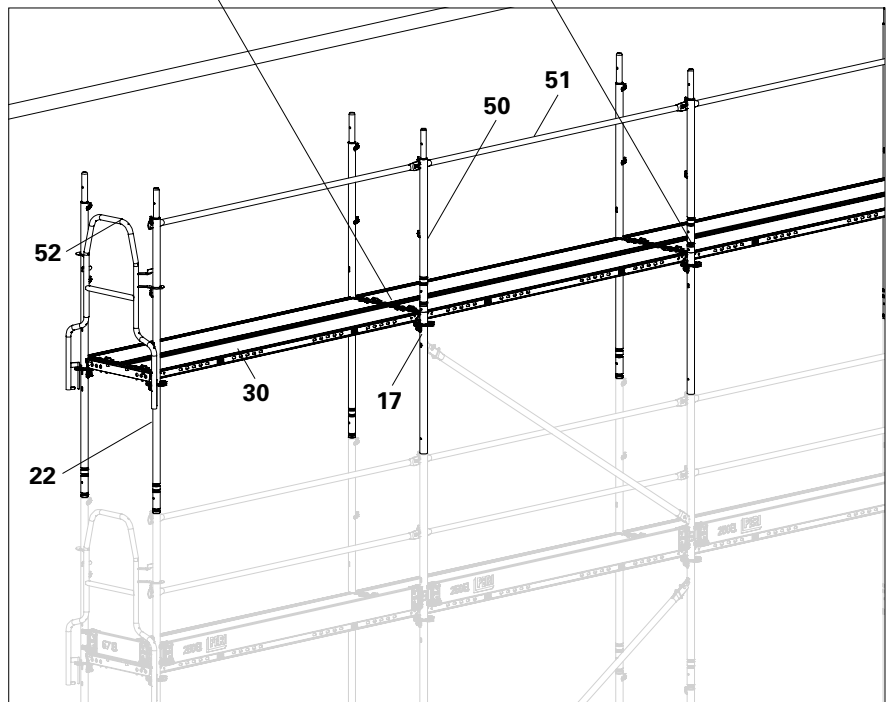

Fig. D1.12

Components

- | | |
|-----------|-------------------------------|
| 17 | Top Standard EVT 96 |
| 22 | Easy Standard EVM 200 |
| 30 | Steel Deck EDS |
| 50 | Guardrail Post EVP |
| 51 | Guardrail Post EPG |
| 52 | Advance End Guardrail UPA 67 |
| 68 | Pin with Spacer Tube URE 4/42 |

Assembly on the top level or on an intermediate scaffold level

- Assembly takes place from the level immediately below:
 1. Fit Console Bracket ECM (63) with Guardrail Post EVP (50). Secure the wedges. See "A6 System components: Console brackets" on page 40 ff.
 2. Fit the Outer Steel Decks EDS (30) and push outwards.
 3. Fit the Inner Steel Decks into the console bracket. (Fig. D1.13)
 4. Anchoring:
 - Anchor each frame column in the console bracket position:
 - Anchor each frame column to the inner and outer legs of the vertical frames with a Wall Tie UWT (46). (Fig. D1.13a + D1.13b)
 - Alternatively, with triangulated ties, anchor every second frame column to the inner standard. Anchor remaining frame columns with single-standard wall ties.
 - Depending on the equipment variation, additional anchoring may be required in the levels underneath.
 - See Section Tie pattern.



The 50 cm standards of the console brackets do not need to be anchored. The anchoring of the inner and outer legs is sufficient. (Fig. D1.13a + D1.13b)

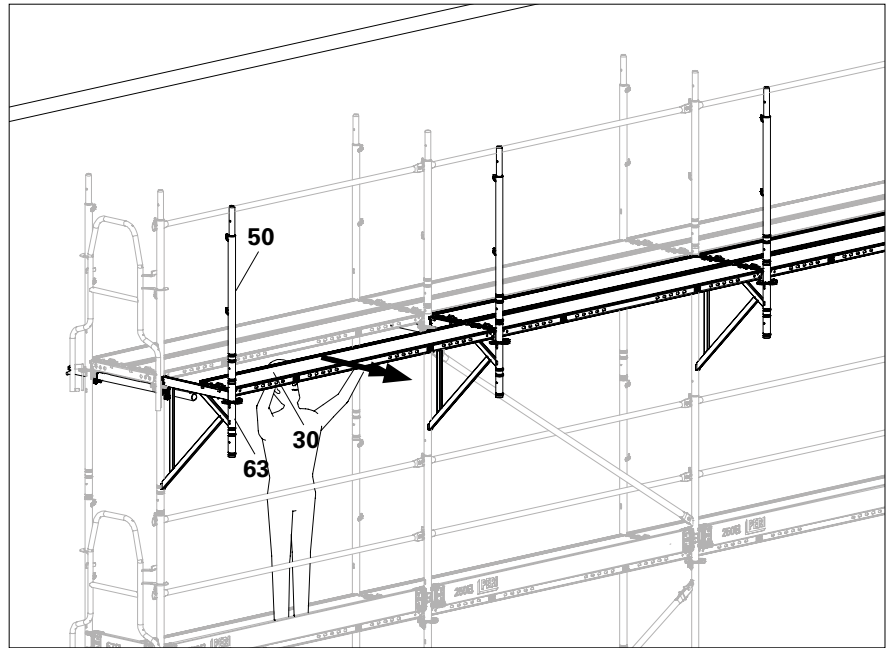

Fig. D1.13

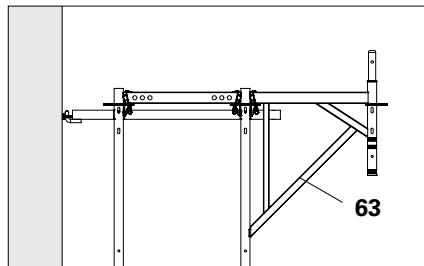

Fig. D1.13a

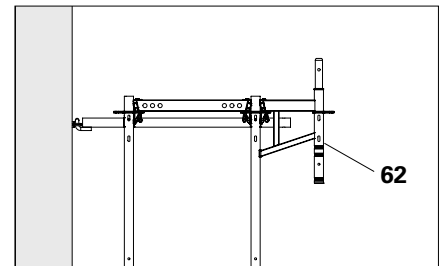

Fig. D1.13b

Components

- 30** Steel Deck EDS
- 50** Guardrail Post EVP
- 62** Console Bracket ECM 33
- 63** Console Bracket ECM 67

- Assembly from a safe position behind the guardrail post of the basic scaffold:
 - 5. Fit a guardrail post (**51**) and an intermediate guardrail (**51a**) in the edge bays, then fit End Guardrail EPF 67 (**54**).
 - 6. In the standard bays, attach Guardrails EPG (**51b**) to the Guardrail Post EVP (**50**) mounted on the Console Brackets ECM.
 - 7. Dismantle the guardrails (**51c**) on the basic scaffold and attach them as intermediate guardrails to the Guardrail Post EVP (**50**) of the console brackets.
- (Fig. D1.14)

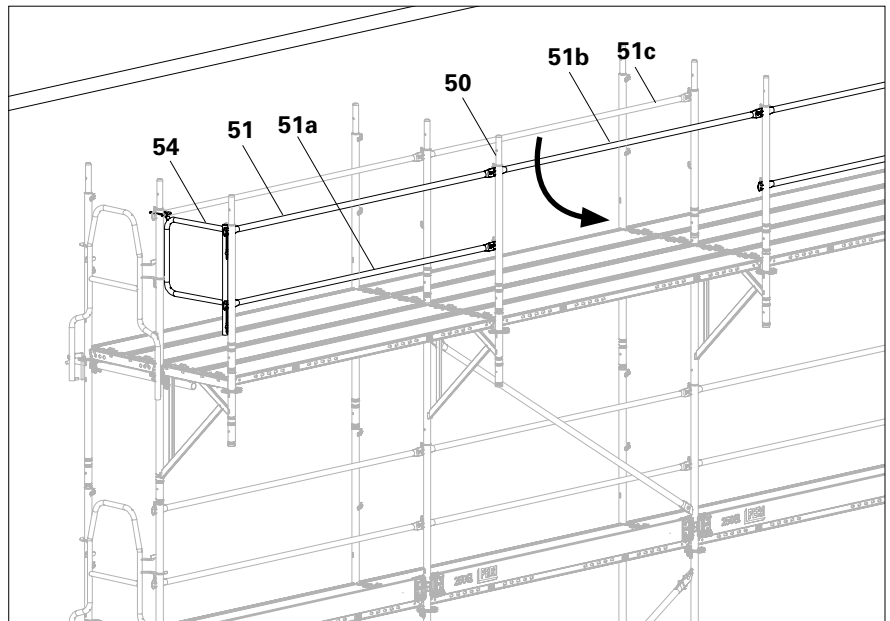

Fig. D1.14

- 8. Fit Toe Boards UPF (**56**).
 - In the top position only:
 - 9. Dismantle Guardrail Post EVP (**50a**) and spigot with Spacer Tube URE (**68**) from the outer Standard EVM.
 - The external console brackets are now installed.
- (Fig. D1.15)

Components

50	Guardrail Post EVP
51	Guardrail Post EPG
54	End Guardrail EPF 67
56	Toe Board UPF
68	Pin with Spacer Tube URE 4/42

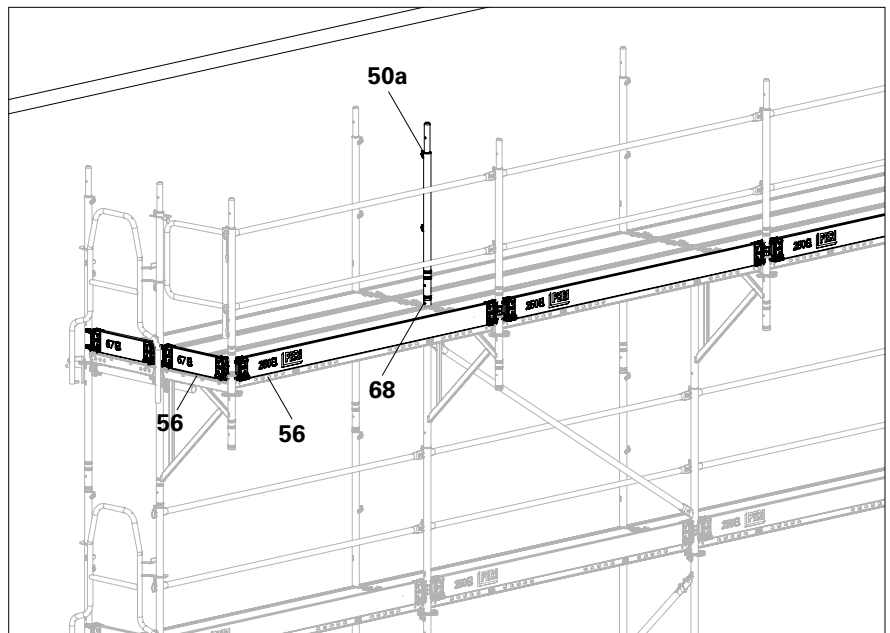

Fig. D1.15

External corner with internal console brackets

The internal console brackets can be installed at the same time on all scaffold levels.

Assemble the basic scaffold in the manner detailed in Section "Outside corner" on page 68. Take into consideration additional space requirements for supports or console brackets on both scaffold bays.



Take additional anchoring for internal console brackets into account, see Section Tie pattern.

Assembly

1. Attach Supports UCS 33 (**60**) and Console Bracket ECM 33 (**62**) from the lower scaffold level to the rosette. Secure the wedges! Arrangement in accordance with Fig. D1.16.
2. Attach Ledger-to-Ledger Coupler UHA-2 (**90**) to the Horizontal Ledger UH-2 (**94a**).
3. Fit Horizontal Ledger UH-2 (**94**) onto the Ledger-to-Ledger Coupler UHA-2 (**90**) and Console Bracket ECM 33 (**62**) in the adjacent scaffold bay. Secure the wedges. (Fig. D1.16)
4. Insert Steel Decks EDS 33 (**30**).
→ The external corner with internal console brackets is now installed. (Fig. D1.17)

Components

30	Steel Deck EDS
60	Support UCS 33
62	Console Bracket ECM 33
90	Ledger-to-Ledger Coupler UHA-2
94	Horizontal Ledger UH-2

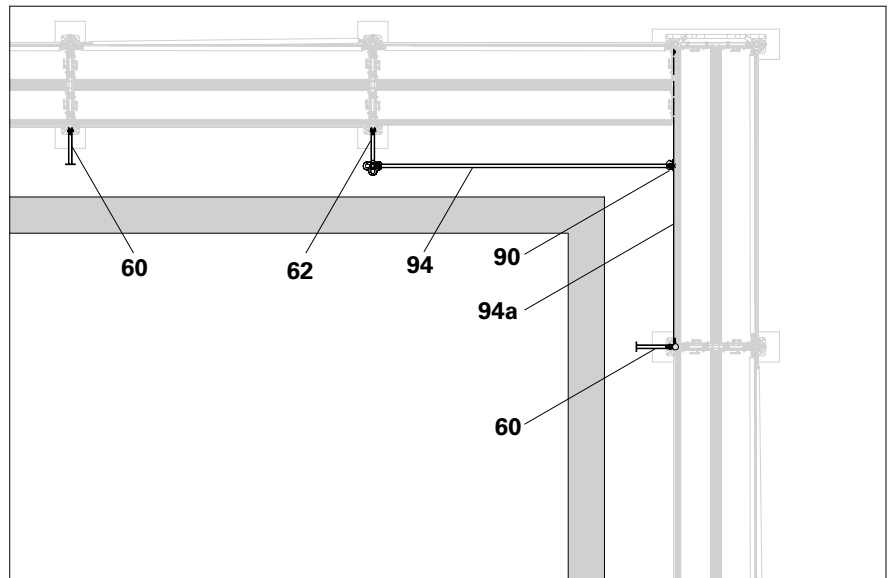

Fig. D1.16

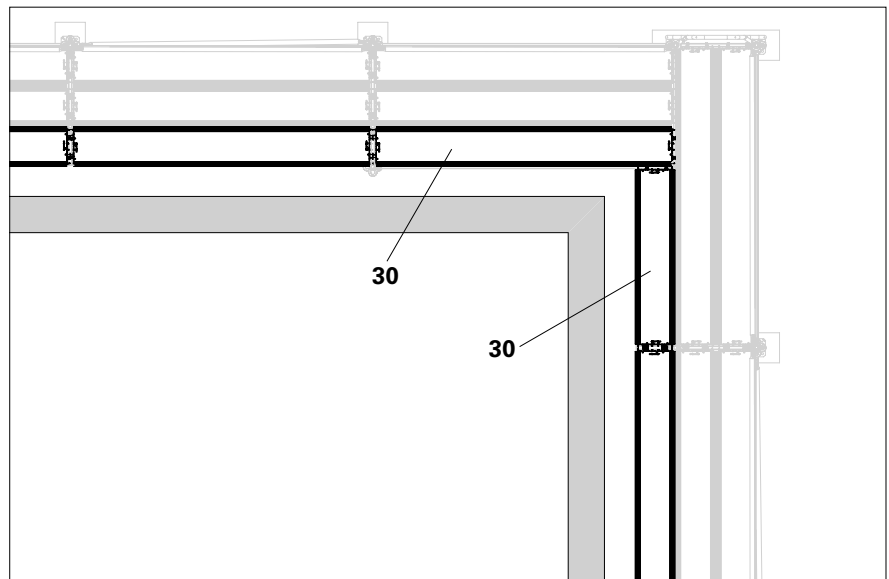

Fig. D1.17

Console brackets at inside corners



Internal scaffolding corners must be realised ensuring that no openings are created.

Fit an Inside Corner Plate EDP (**34**) for the remaining internal corner (Fig. D1.18 – D1.20)

- The Inside Corner Plates EDP can be used for internal console bracket widths of 25 and 33 cm
- max. load class 4 according to EN 12811
($p = 3.0 \text{ kN/m}^2$)

Assembly

- From a safe position on the scaffold level immediately below:
 1. Fit console brackets or supports on the inner side of the scaffolding.
 2. Place the Inside Corner Plate EDB (**34**) next to the adjacent console bracket decks.
 3. Push the bolts of the Inside Corner Plate EDP (**34.1**) up.
 4. Push the inside corner plate towards the standard and slide the standard mounting cone over the rosette.
 5. Push the bolt into the hole of the rosette until it fully engages.
 - The deck is now fixed in position
 - The inside corner with internal console brackets is now installed.
- (Fig. D1.18 + D1.18a)



Is the bolt securely engaged in the rosette?

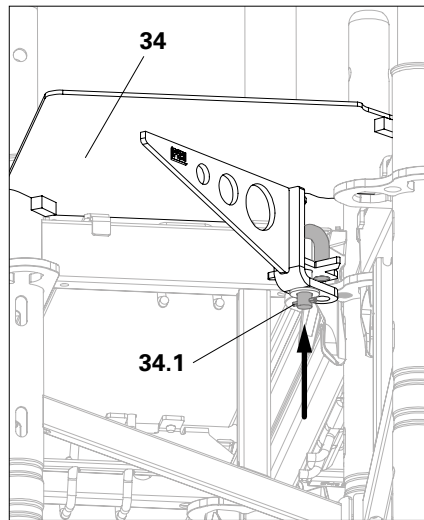

Fig. D1.18

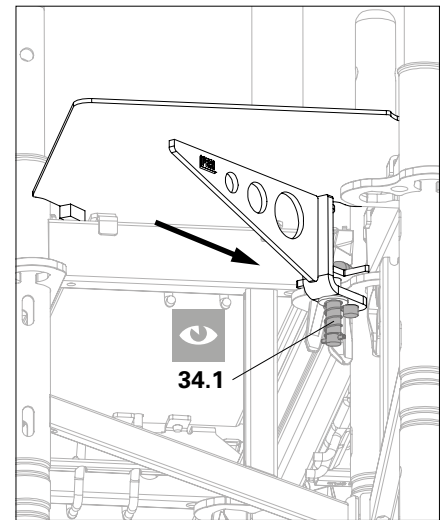

Fig. D1.18a

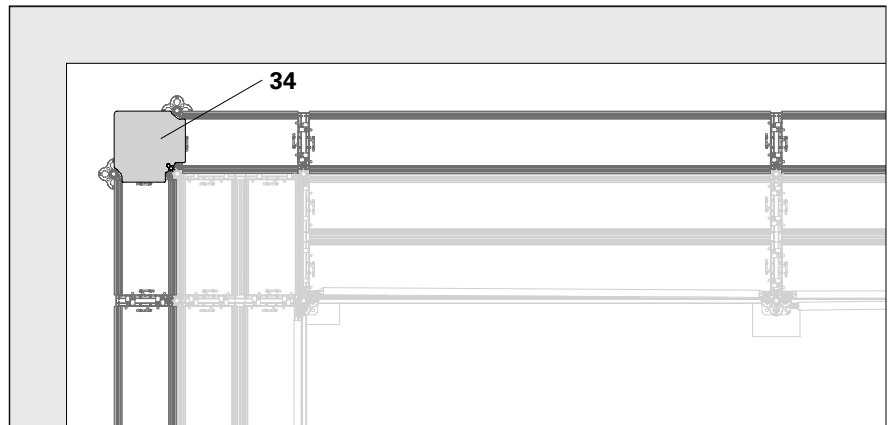

Fig. D1.19

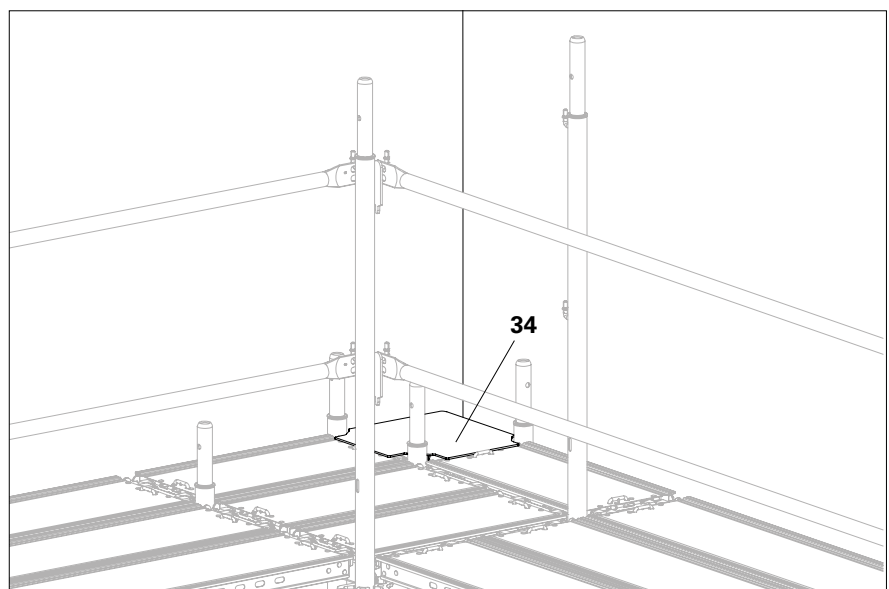

Fig. D1.20

General

Protection panels with safety nets (in Europe, e.g. according to DIN EN 1263) are installed on Guardrail Posts EPG in the top scaffold level.



- Note additional anchoring, see Section Tie pattern.
- For the permissible Load Classes, see Section "A6 System components: Console brackets" on page 40.
- Securely connect all frame columns in the top three levels to the outer and inner legs using locking pins (19).

Protection panel on the base scaffold

Assembly

1. Assemble top scaffold level with Easy Standards (22) and Guardrail Post in Advance EPG (51). Insert Steel Decks EDS (30).
2. Attach Guardrail Post EVP (50) to outer Easy Standard (22).
3. Connect the guardrail post (50) and the outer tube with a locking pin (19) so that they are tension-proof. (Fig. D2.01)
4. Anchoring:
 - Anchor every frame column in the protection panel position.
 - Anchor every second frame column with Wall Ties UWT (46) to the inner and outer legs; alternatively, anchor with triangulated ties to the inner standard.
 - Anchor remaining frame columns with single-standard wall ties.
 - Depending on the equipment variation selected, further anchoring may be required.
 - See Section Tie pattern.

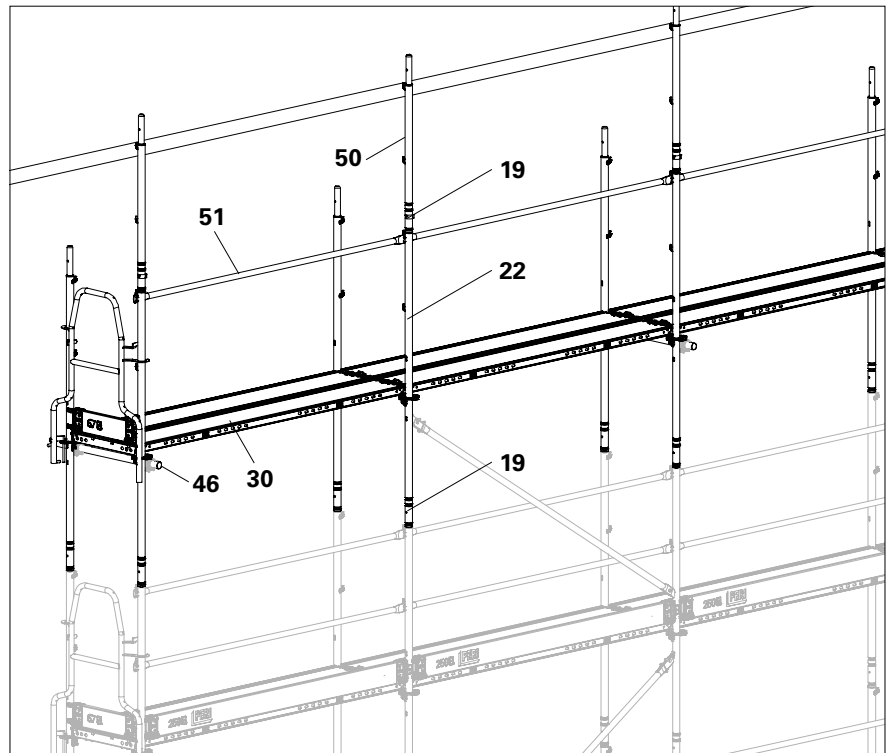

Fig. D2.01

Components

22	Easy Standard EVM 200
30	Steel Deck EDS
46	Wall Tie UWT
50	Guardrail Post EVP
51	Guardrail Post EPG
56	Toe Board UPF
59	Guardrail Holder EPW

D2 Protection panel

Installing the safety net

1. Thread Guardrail Post EPG (**51a**) through the mesh at the top edge of the safety net.
2. Attach Guardrail Post (**51a**) to the top guardrail hooks, 2 m above the deck level.
3. Install the intermediate guardrail (**51b**). As seen from the scaffold, the net must hang in front of the guardrail post (**51**) and behind the intermediate guardrail (**51b**). (Fig. D2.02 + D2.02a)

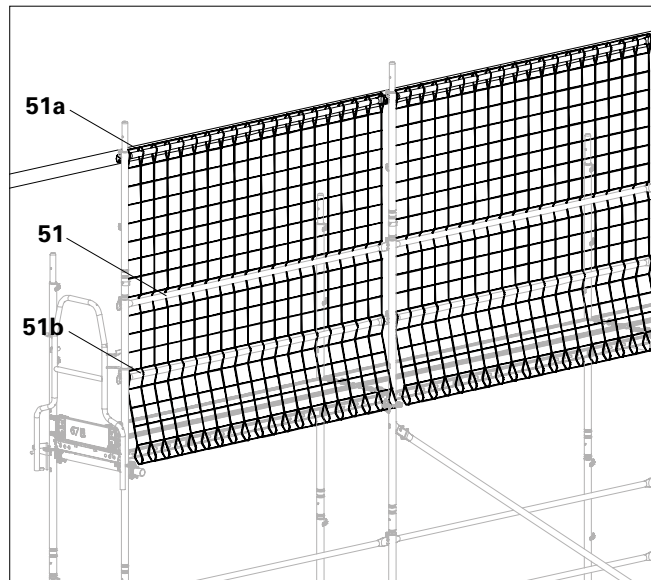

Fig. D2.02

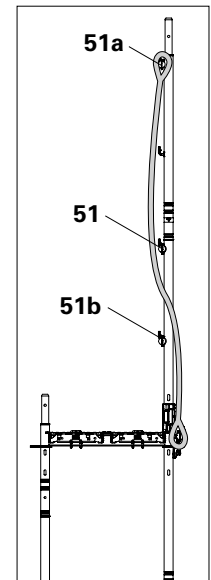

Fig. D2.02a

4. Fit Guardrail Holder EPW (**59**) into the rosette of the Easy Standard.
 5. Thread Guardrail Post EPG (**51**) through the mesh at the bottom edge of the safety net and attach it to the guardrail hooks (**59.1**) of the Guardrail Holder EPW.
 6. Secure the guardrail posts on the Guardrail Holder EPW at the beginning and end of the protection panel with suitable means. (Fig. D2.03a)
 7. Fit Toe Boards UPF (**56**) onto the protection panel.
- The protection panel is now installed. (Fig. D2.03)



Safety nets with sewn-on loops or clips are to be installed according to the specifications of the net manufacturer.

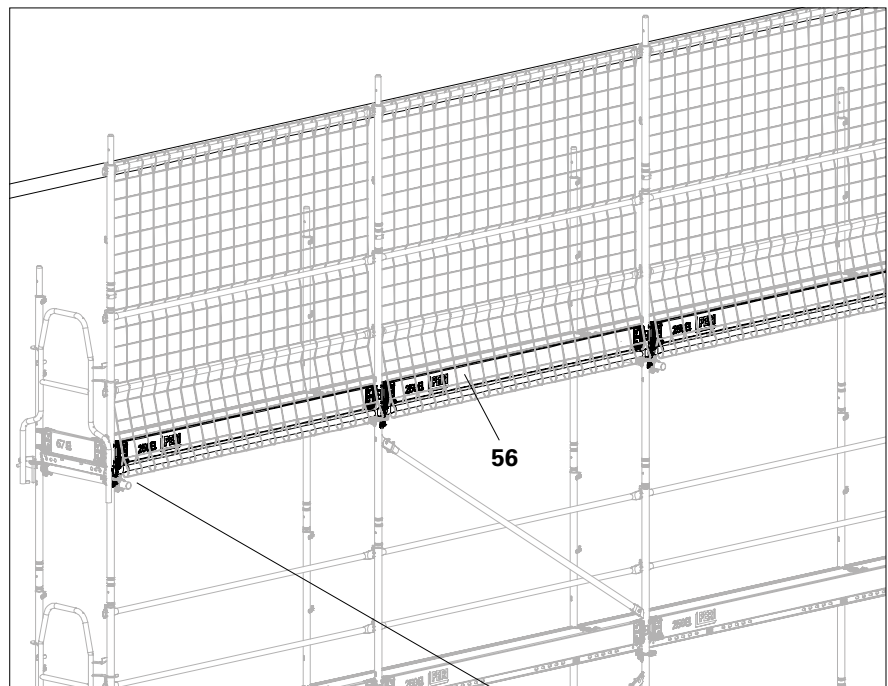

Fig. D2.03

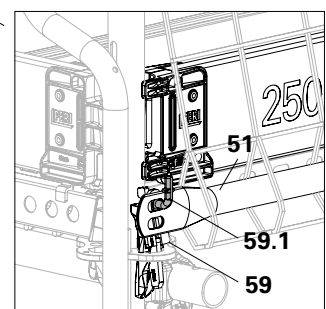

Fig. D2.03a

Protection panel on external console brackets

Assembly

- From the level immediately below:
 1. Assemble the outer legs of the top level of the basic scaffold in the area of the roof overhang with Top Standard EVT 96 (17), spigot with Spacer Tube URE (68), Guardrail Post EVP 100 (50) and Guardrail in Advance EPG (51). Build up the edge frame with Easy Standard EVM (22).
 2. Install Steel Decks EDS (30) in the basic scaffold.
- (Fig. D2.04)



For frame columns with diagonal ends above: insert the short spigot of the spacer tube (68) into the top standard, see Section "External console brackets" on page 111

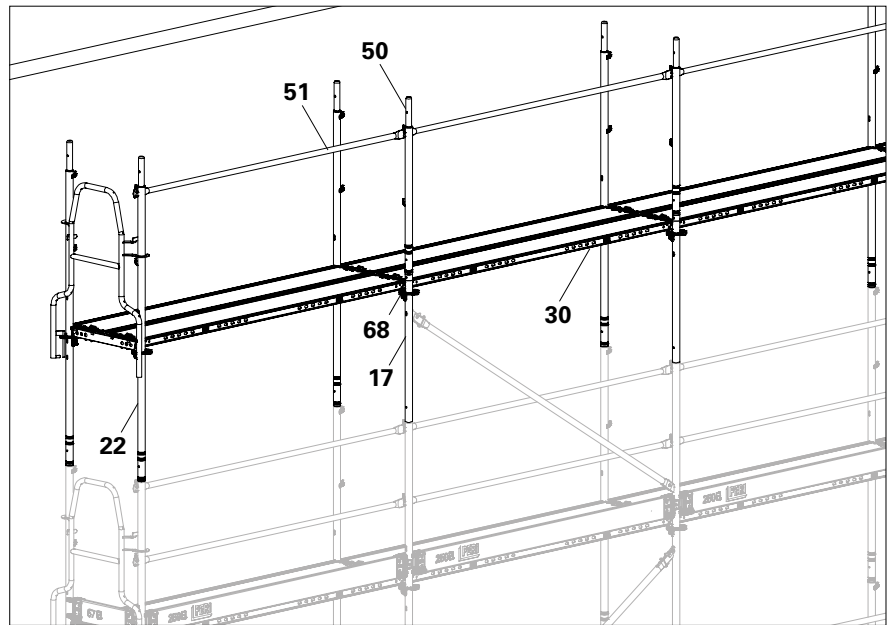

Fig. D2.04

Components

-
- 17 Top Standard EVT 96
 - 22 Easy Standard EVM 200
 - 30 Steel Deck EDS
 - 46 Wall Tie UWT
 - 50 Guardrail Post EVP
 - 51 Guardrail Post EPG
 - 62 Console Bracket ECM 33
 - 67 Protection Panel Post EPS
 - 68 Pin with Spacer Tube URE 4/42
-

Console Bracket ECM 33

1. Fit Console Bracket ECM 33 (62) together with the Protection Panel Post EPS (67), see Section "A6 System components: Console brackets" on page 40 ff.
2. Securely connect the protection panel post (67) and console bracket (62) using a locking pin (19).
3. Secure every console bracket against lifting using a Guardrail Coupling EPR (58). (Fig. D2.05a)
4. Attach Steel Decks EDS (30).
5. Anchoring:
 - Anchor every frame column in the protection panel position.
 - Anchor each frame column to the inner and outer leg of the vertical frames with a wall tie (46).
 - Alternatively: anchor frame columns to the inner standard of the vertical frames alternating between single-standard wall ties and triangulated ties. (not shown)
 - Depending on the equipment variation selected, further anchoring may be required.
 - See Section Tie pattern. (Fig. D2.05)

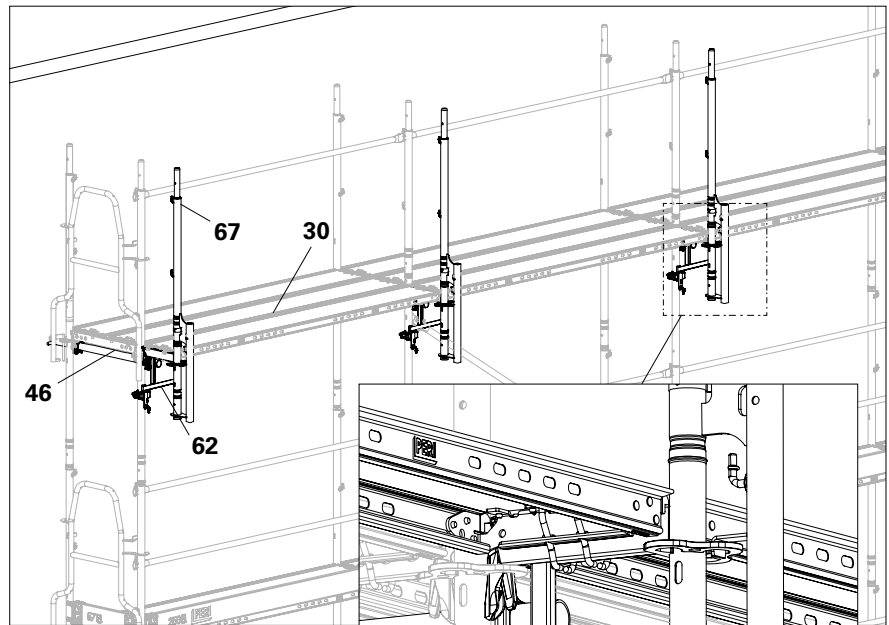

Fig. D2.05

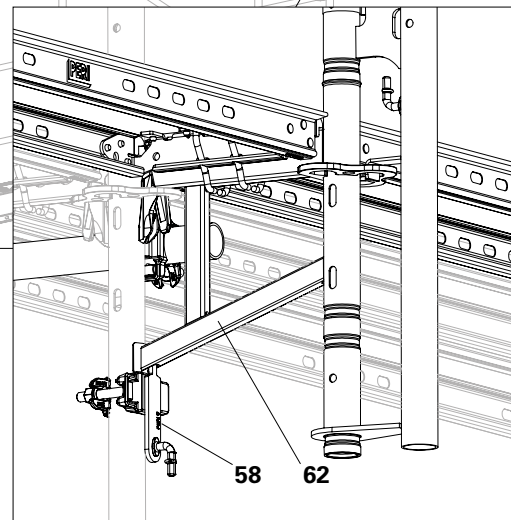

Fig. D2.05a

Console Bracket ECM 67

1. Fit Console Bracket ECM 67 (**63**) together with the Protection Panel Post EPS (**67**), see Section "A6 System components: Console brackets" on page 40 ff.
2. Securely connect the protection panel post (**67**) and console bracket (**63**) using a locking pin (**19**).
3. Insert Steel Decks EDS (**30**) into the console brackets, and push them outwards.
4. Anchoring:
 - Anchor every frame column in the protection panel position.
 - Anchor each frame column to the inner and outer leg of the vertical frames with a wall tie (**46**). (Fig. D2.06)
 - Alternatively: anchor frame columns to the inner standard of the vertical frames alternating between single-standard wall ties and triangulated ties. (not shown)
 - Anchor every frame column in the scaffold level directly below using a single-standard wall tie.
 - See Section Tie pattern. (Fig. D2.06)

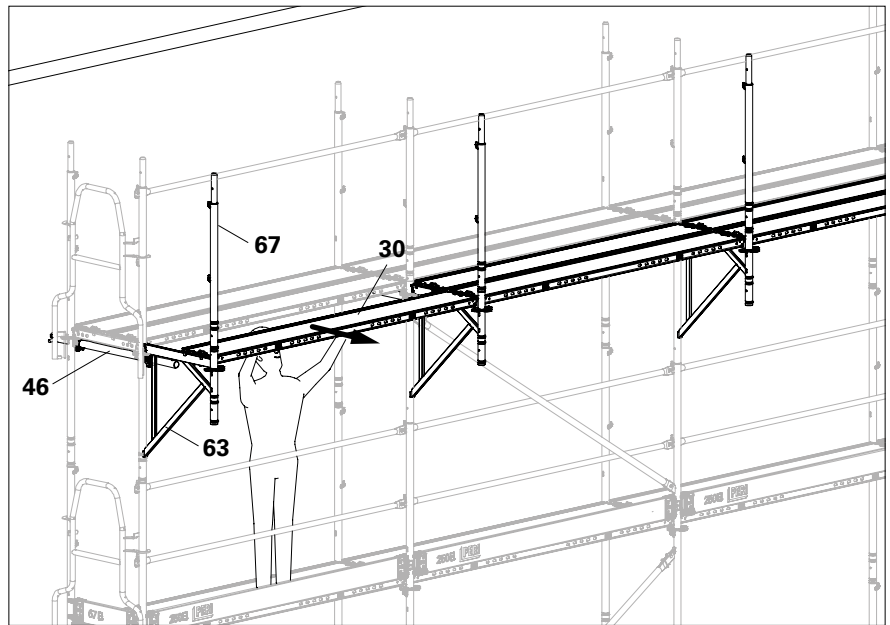

Fig. D2.06

Fitting the protection panel

In the case of Console Brackets ECM 33 and 67, assembly is carried out in the same way.

■ Carry out the assembly process from a safe position behind the guardrail in advance:

1. Fit a guardrail post (**51**) and an intermediate guardrail (**51a**) in the edge bays, then fit End Guardrail EPF (**54**).
2. In the intermediate bays, attach Guardrail Posts EPG (**51b**) to the Protection Panel Posts EPS (**67**).
3. Dismantle guardrail posts (**51c**) on the basic scaffold and attach them as intermediate guardrails on the Protection Panel Posts EPS (**67**).
4. Install Toe Board UPF (**56**) in the edge bays.
5. Remove Guardrail Post EVP (**50**) from the head frame and position on the protection panel posts. Guardrail pins must be pointing towards the middle of the scaffolding.
6. Securely connect the guardrail post (**50**) and protection panel post (**67**) using a locking pin (**19**).
7. Remove the spigot with Spacer Tube URE (**68**).

(Fig. D2.07)

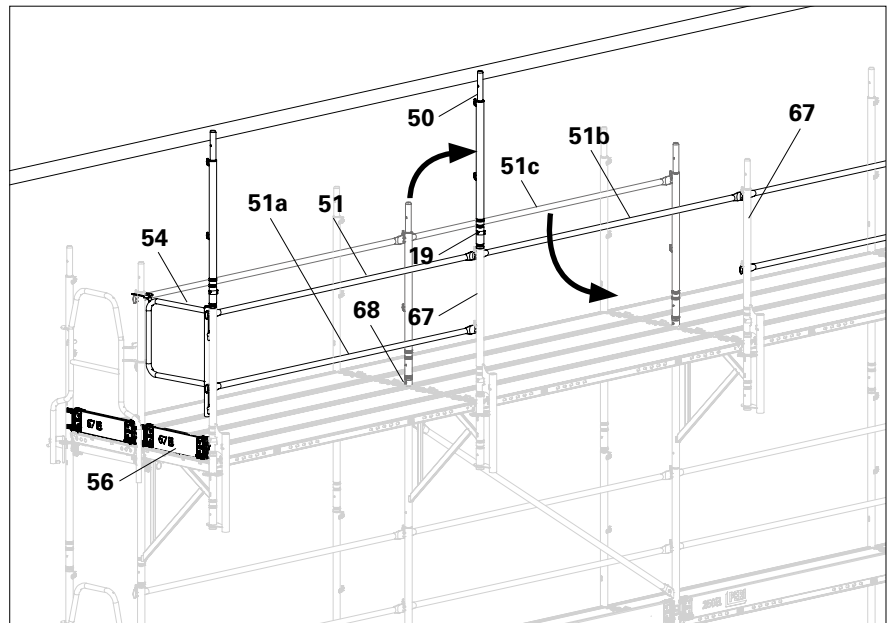

Fig. D2.07



Depending on the roof overhang, it may be necessary to use PPE for assembly operations.

Components

- | | |
|-----------|-------------------------------|
| 30 | Steel Deck EDS |
| 46 | Wall Tie UWT |
| 50 | Guardrail Post EVP |
| 51 | Guardrail Post EPG |
| 54 | End Guardrail EPF |
| 56 | Toe Board UPF |
| 67 | Protection Panel Post EPS |
| 68 | Pin with Spacer Tube URE 4/42 |

Installing the safety net

1. Thread Guardrail Post EPG (**51a**) through the mesh at the top edge of the safety net.
2. Attach Guardrail Post (**51a**) to the top guardrail hooks, 2 m above the deck level.
3. As seen from the scaffold, the safety net hangs in front of the guardrail post (**51**) and behind the intermediate guardrail (**51b**). (Fig. D2.08 + D2.08a)

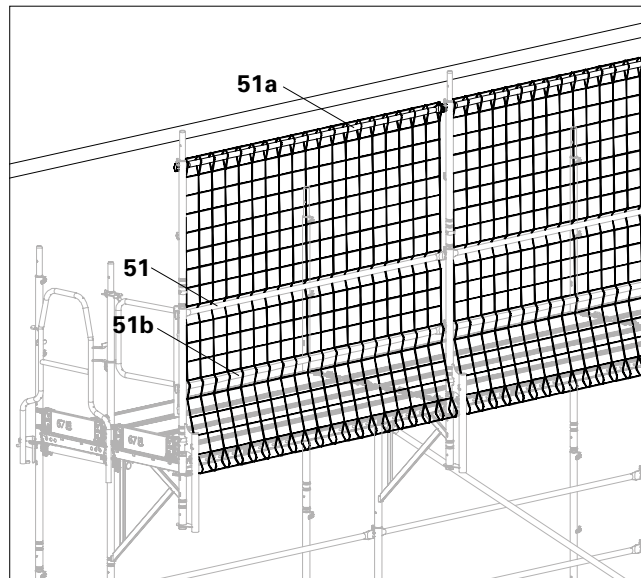

Fig. D2.08

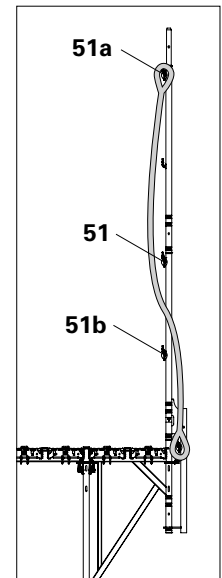

Fig. D2.08a

4. Thread Guardrail Post EPG (**51**) through the mesh at the bottom edge of the safety net and attach it to the guardrail hooks (**67.1**) of the Protection Panel Post EPS.
5. Secure the guardrail posts on the protection panel post at the beginning and end of the protection panel with suitable means.
6. Install Toe Boards UPF (**56**).
→ The protection panel is now installed. (Fig. D2.09)



Safety nets with sewn-on loops or clips are to be installed according to the specifications of the net manufacturer.

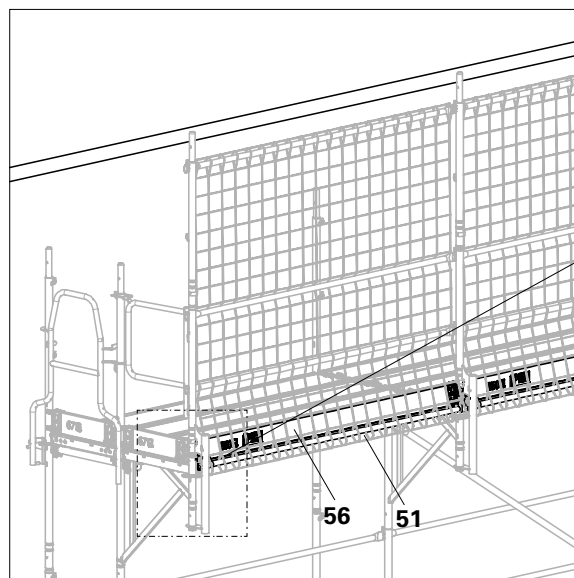
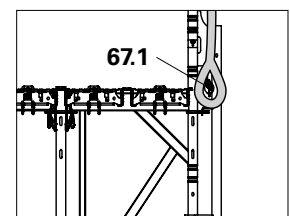
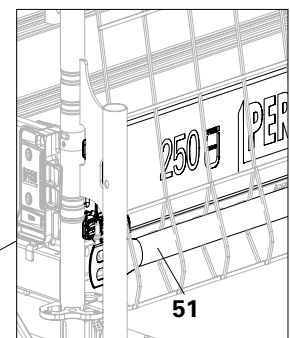

Fig. D2.09



General

The weather protection must be closed on all sides. No more than 10 % of the facade should be open.

Pull tarpaulins all the way around the front sides.

Fit the tarpaulins in accordance with the manufacturer's information.

(Fig. D3.01)

Not approved for assembly on console brackets.

Technical data

- No snow load, but 0.10 kN/m², minimum load similar to DIN EN 16508.
- Wind load q max. with 0.20 kN/m². If greater wind loads are to be expected, suitable securing measures, e.g. removing tarpaulins, must be taken in good time.
- System width 67 cm with EVW 130:
 - up to scaffold bay length ≤ 250 cm without support.
 - up to scaffold bay length 300 cm with support.
- System width 100 cm with EVW 180:
 - all scaffold bay lengths with support.

Anchoring



- Take additional anchoring (46) into account, see Section "Tie pattern" on page 128.
- From the uppermost anchored level to the next anchored level, securely connect all frame columns to the outer and inner standards using locking pins.
- Depending on the tarpaulin quality and tension, it may be necessary to implement additional measures to prevent water sacks from forming on the tarpaulin. For example, fitting Horizontal Ledgers UH-2 onto all rosette nodes on the roof standard.

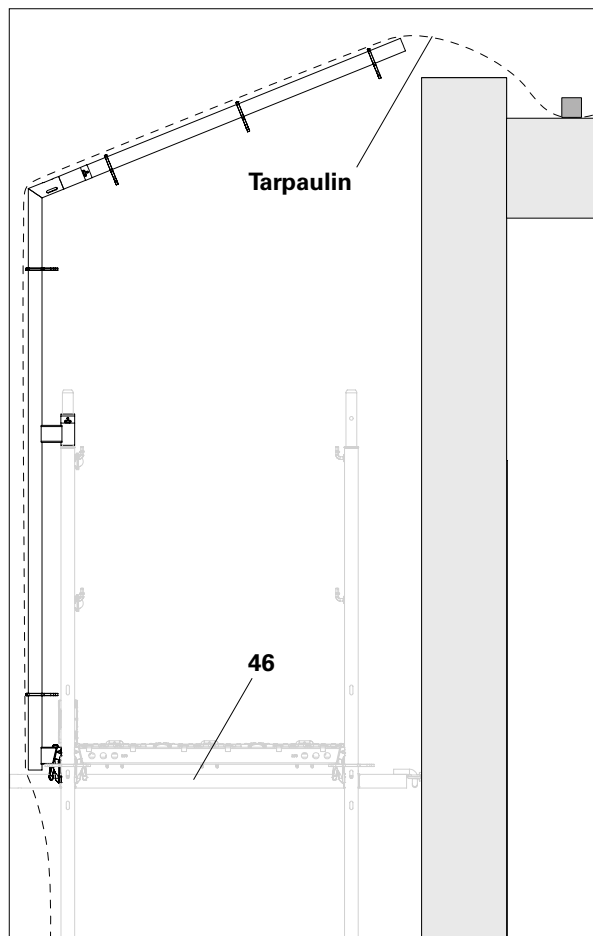

Fig. D3.01

Components

-
- 22** Easy Standard EVM 200
 - 19** Locking Pin Ø 48/57
 - 46** Wall Tie UWT
 - 104** Weather Protection EVW 200-V
 - 105** Weather Protection EVW 130
 - 107** Spindle Head SRU
 - 108** Coupling EVW
 - 109** Top Standard UVH 100
-

Assembly

Fitting the outer leg and roof standard

1. Fit Weather Protection EVW 200-V (104) onto the spigot of the erected scaffold using the top connection while simultaneously inserting it into the rosette below.
 2. Secure the wedge.
 3. Secure Weather Protection EVW 200-V on the outer Easy Standard EVM (22) with a locking pin (19)
 3. Fit Weather Protection EVW 130 (105) or EVW 180 onto the spigot of EVW 200 and secure it with a locking pin (19a).
 - Three-quarters of the rosette must be pointing downwards.
 - The outer leg and roof standard are now installed.
- (Fig. D3.02)

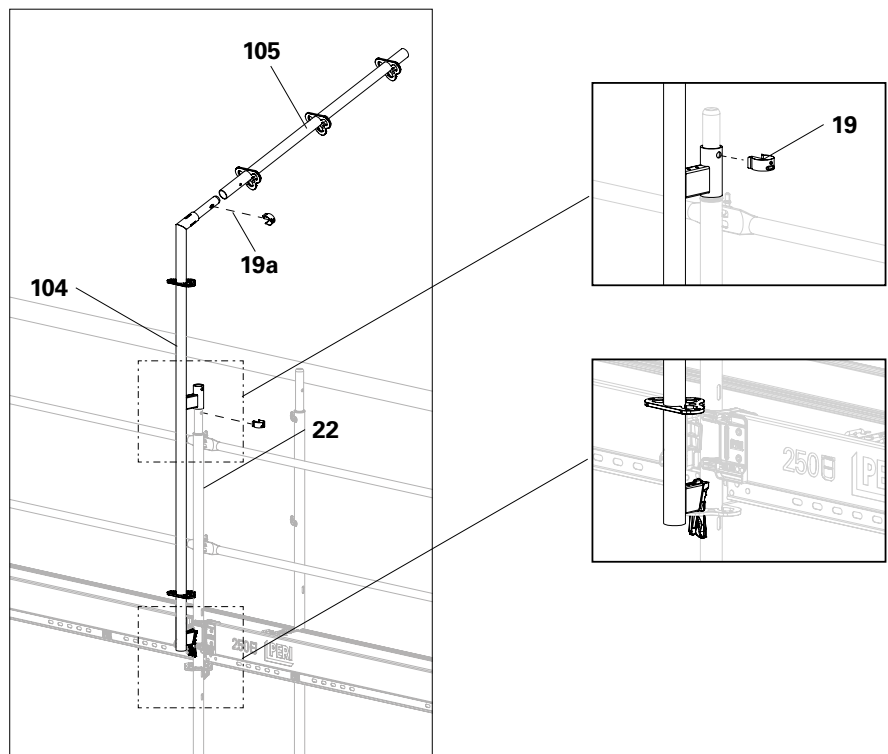

Fig. D3.02

Fitting the inner leg



The inner leg is always required for internal support when the bay is 3 m long or if Weather Protection EVW 180 is used. In other cases, the inner leg is not strictly necessary, but can be used in the event of enhanced requirements.

1. Pin the Spindle Head SRU (107) and Coupling EVW (108) with a fitting pin (107.2) and secure them with a cotter pin (107.3).
 2. Screw the quick jack nut (107.1) all the way up.
 3. Insert the spindle head into Top Standard UVH (109).
- (Fig. D3.03)

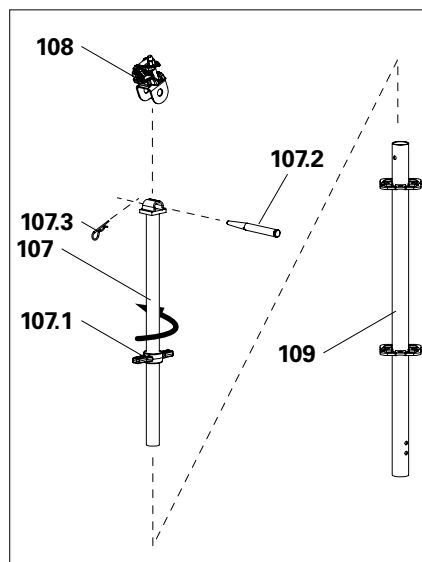

Fig. D3.03

4. Open Coupling EVW (**108**), fit the pre-assembled inner standard onto the roof rail from below and fit Top Standard UVH (**109**) onto the inner Easy standard (**22**).
5. Secure the top standard with a locking pin (**19**).
6. Screw the quick jack nut (**107.1**) down until the coupling is resting on the roof rail again.
7. Close the coupling around the roof rail and tighten the nut. Tightening torque 50 Nm.
→ The inner leg is now installed.
(Fig. D3.04)

Components

- 19** Locking Pin Ø 48/57
- 22** Easy Standard EVM 200
- 50** Guardrail Post EVP
- 106** Weather Protection EVW 180
- 107** Spindle Head SRU
- 108** Coupling EVW
- 109** Top Standard UVH 100
- 110** Head Spindle Lock UJH

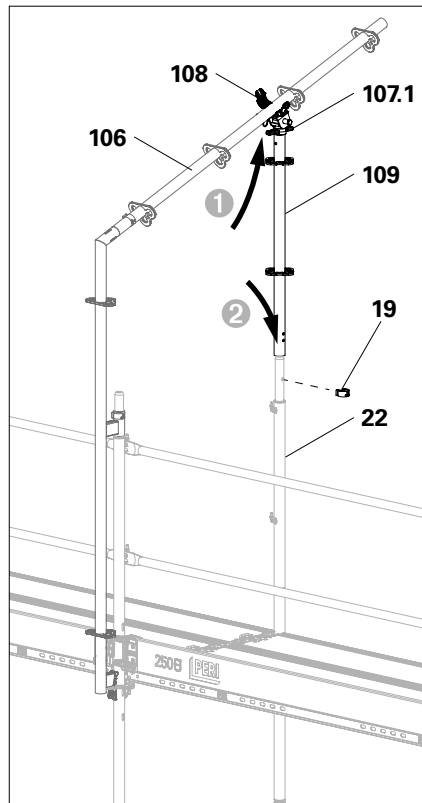

Fig. D3.04

Bracing system width 100 cm

1. In each bay, fit the horizontal ledgers (**94a**) onto the outer legs as shown in the figure.
 2. Fit the horizontal ledgers (**94b**) onto the roof standards and hammer it into place immediately so that it does not fall down.
 3. Brace the inner legs in pairs using horizontal ledgers (**94c**). If there is another free-standing inner leg, this should also be connected with a horizontal ledger.
 4. Continue the arrangement of all diagonals in the basic scaffold into the weather protection roof using Ledger Braces UBL (**99**).
- The bracing is now installed.
(Fig. D3.05)

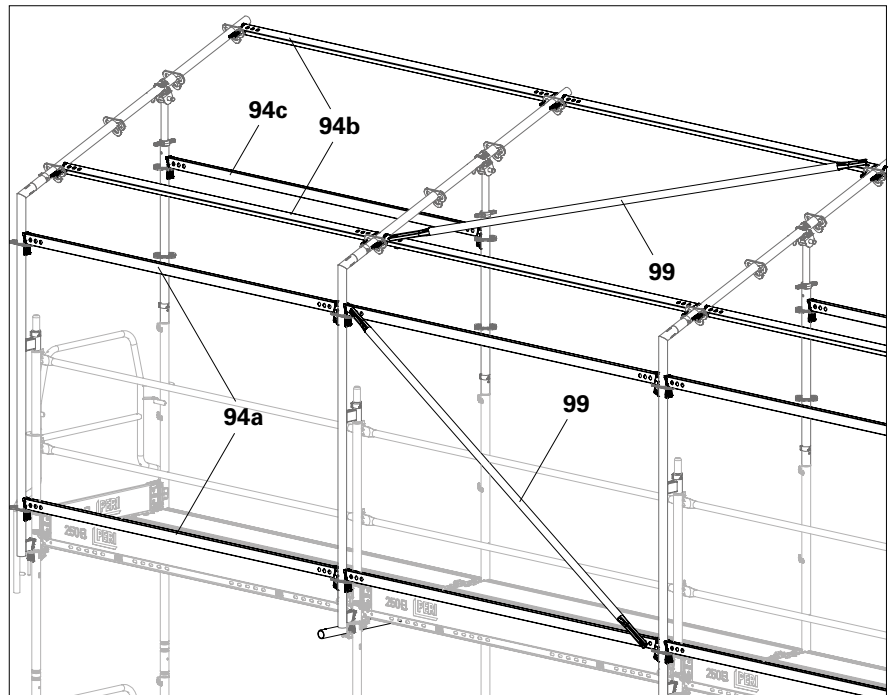

Fig. D3.05

Fitting spindle locking

1. Pull the cotter pin (**110.3**) and wedge (**110.2**) out of the spindle locking up to the stop.
 2. Place the head spindle locking (**110**) on the horizontal ledger at an angle and insert the hooks (**110.1**) into the rosette holes (**109.1**) from below.
 3. Swivel the head spindle locking upwards over the quick jack nut (**107.1**), hammer in the wedge (**110.2**) and secure with a cotter pin (**110.3**).
- Spindle locking is now installed.
(Fig. D3.06)

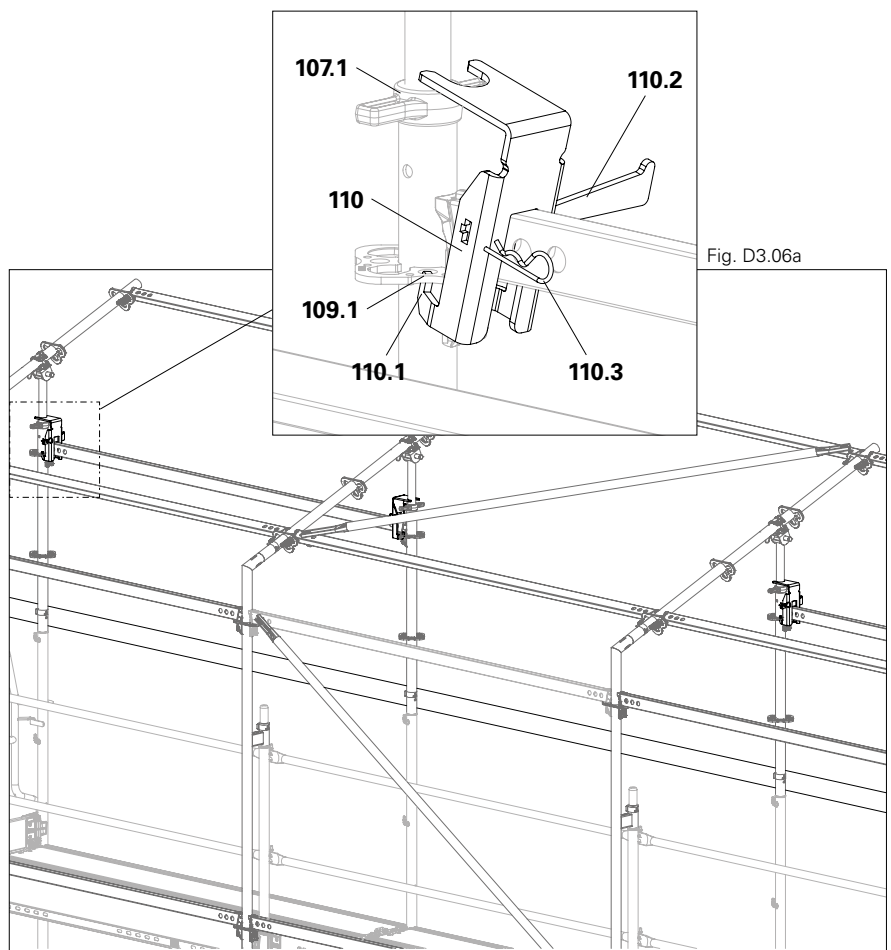

Fig. D3.06a

Fig. D3.06

Bracing system width 67 cm

1. In each bay, fit the horizontal ledgers (94a) onto the outer legs as shown in the figure.
 2. Fit the horizontal ledgers (94b) onto the roof standards and hammer it into place immediately so that it does not fall down.
 3. Continue the arrangement of all diagonals in the basic scaffold into the weather protection roof using Ledger Braces UBL (99).
- The bracing is now installed.
(Fig. D3.07)

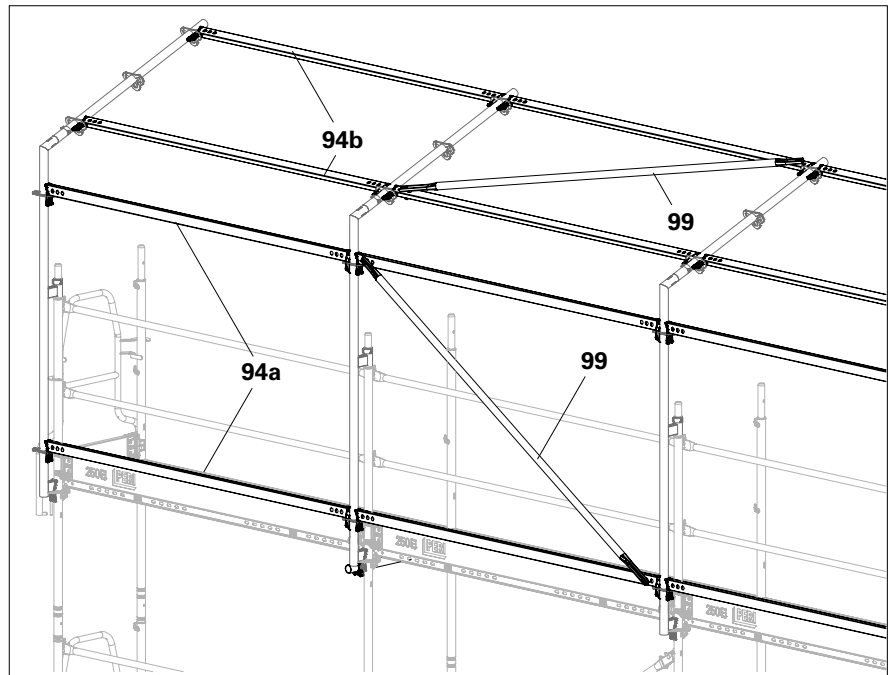

Fig. D3.07

Tie pattern

Minimum requirements for anchoring the top level:

- Anchor every second frame column to the inner and outer legs with Wall Ties UWT (46).
 - Anchor remaining frame columns with single-standard wall ties (46a).
- (Fig. D3.08)



Stronger ties or bracing that are suitable for the intended tie pattern must be used.
(Fig. D3.08a)

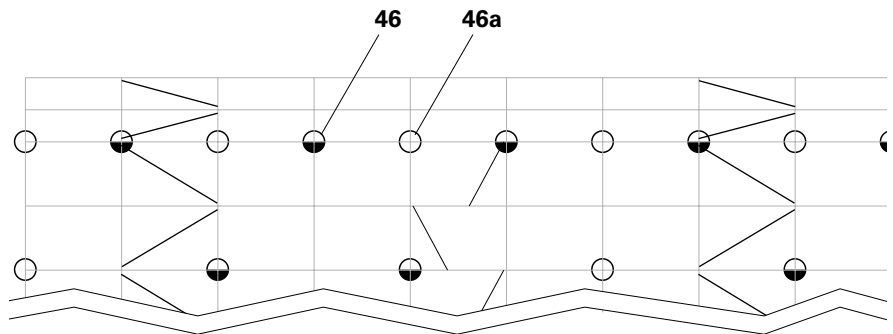

Fig. D3.08

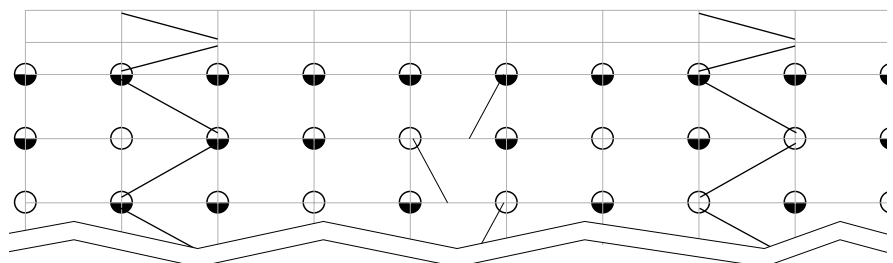

Fig. D3.08a

Keder tracks

The LGS Keder Track URK (**131**) is suitable for tarpaulins with 13 mm keder. LGS Keder Connector URV (**132**) is used for assembly on the scaffold.



- Fit the keder connections a maximum of 1.50 m apart.
- Fit at least 2 keder connections for each keder track.

Fit the keder track connection at the joint of the keder tracks in an overlapping manner.

Assembly

1. Cut the LGS Keder Track URK (**131**) to the required length and remove the burr.
 2. Slide the terminal strip (**132.1**) on the Keder Connector URV (**132**) into the T-groove (**131.1**) of the Keder Track URK and bolt it into place.
 3. Fit the coupling side (**132.2**) of the keder connection on the pre-assembled keder tracks onto Weather Protection EVW (**105 + 104**). Leave a little clearance at the joint between the vertical rail and roof rail to make it easier to thread in the tarpaulin.
- The keder track is now installed.
(Fig. D3.10)

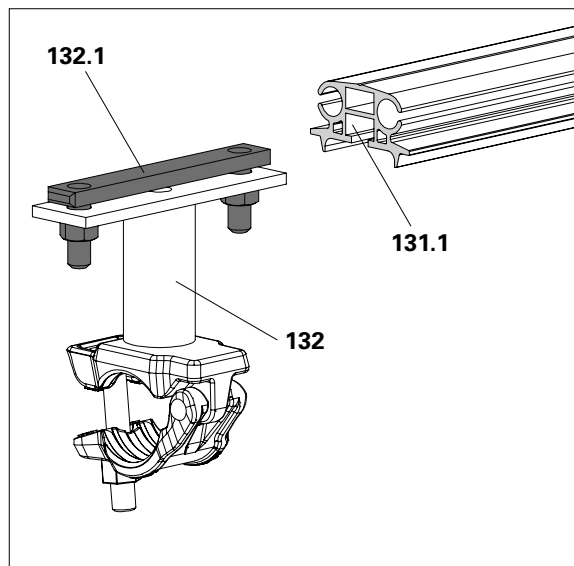

Fig. D3.09

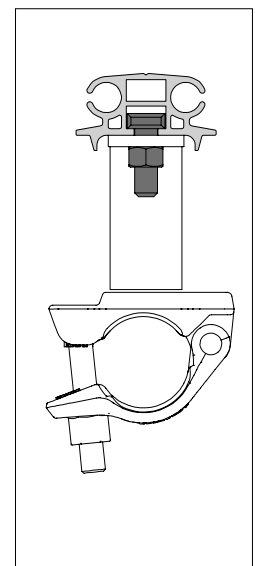

Fig. D3.09a

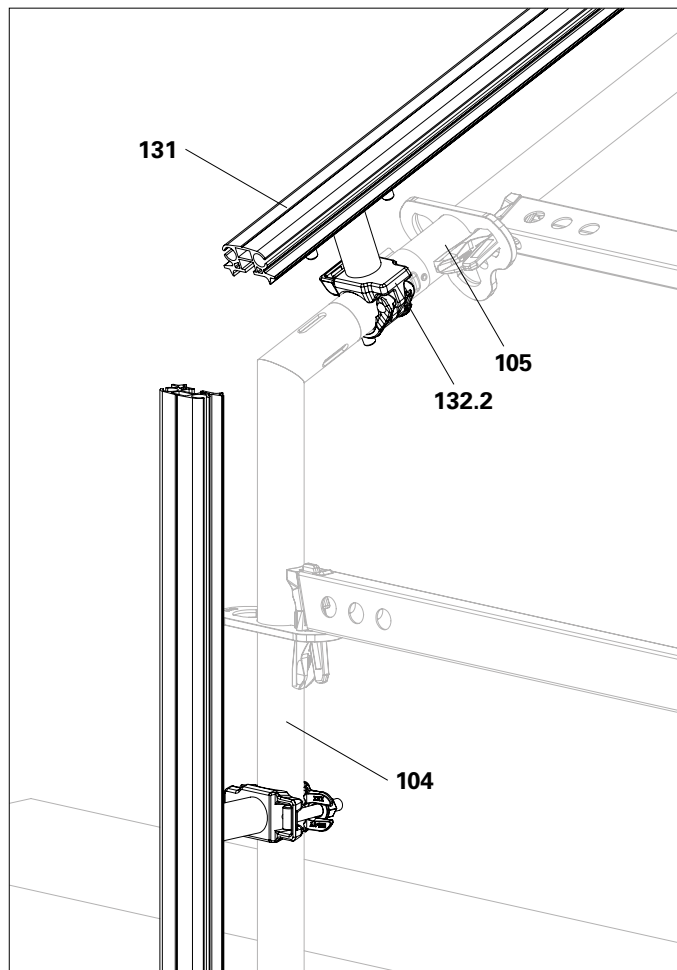

Fig. D3.10

General

The deck must be installed flush with the basic scaffold.

The following are used for assembling the protection roof:

- Console Bracket ECM 67 (**63**)
- Console Brackets ECM 100.



Placing materials on the protection roof is not permitted!

The effect of the protection roof can be impaired by materials being placed on it!

Protection roof on external console bracket

Assembly

Installation of the console brackets and decks is carried out from the lower scaffold level, in the protection of the lateral protection installed beforehand.

1. Fit Protection Roof Connector EPC (**66**) into Console Bracket ECM 67 (**63**) and secure with tube clip (**21**) or bolts M10 x 70 and nuts.
2. Fit Console Bracket ECM 67 with attached Protection Roof Connector EPC, see Section "A6 System components: Console brackets" on page 40 ff.

(Fig. D4.01)

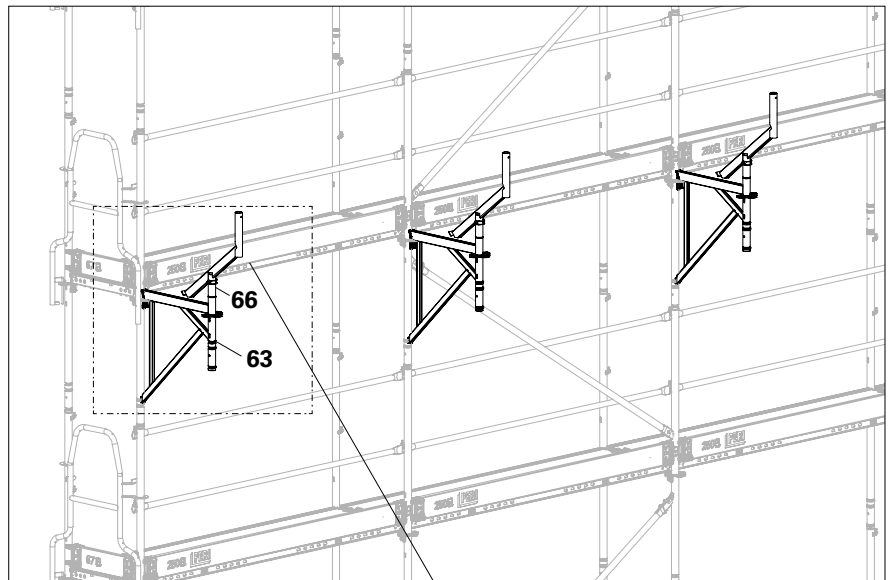
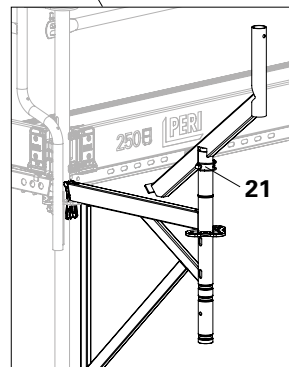

Fig. D4.01



3. Fit the first Steel Deck EDS (**30**) and push it outwards.
4. Fit a second steel deck.
Alternatively, fit steel decks from level above.

5. Anchoring:

- In the protection roof position, anchor each frame column to the inner and outer legs using a Wall Tie UWT (**46**).
- Alternatively, anchor them on the inner standard using triangulated ties.
- Depending on the structural arrangement selected, additional ties may be required in further scaffold levels, see Section Tie pattern.

(Fig. D4.02)

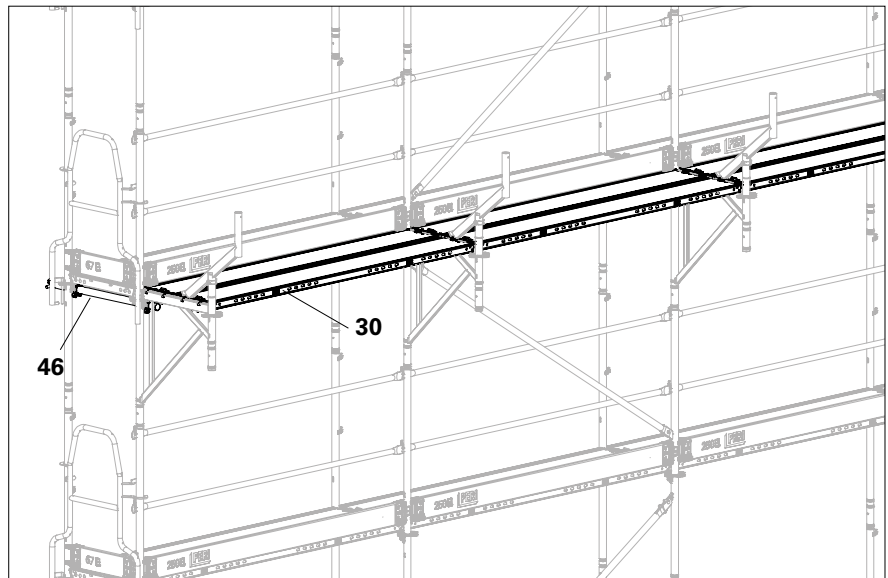

Fig. D4.02

6. Position Steel Decks EDS (**30**) on the Protection Roof Connector EPC.
 7. Insert Toe Board UPF (**56**) into Protection Roof Connector EPC and secure with suitable means. (Fig. D4.03a)
- The protection roof is now installed. (Fig. D4.03)

The Guardrail Posts EPG (**51**) installed in the basic scaffold separate the protection roof from the working area.



- Depending on the scaffold components or static configuration, install additional measures, e.g. anchoring, in the scaffold level positioned immediately below with single-standard wall ties, see Section Tie pattern.
- Width class B2 according to DIN EN 12811-4 is achieved when Console Brackets ECM 67 (**63**) are used.
- Width class B3 is achieved with Console Brackets ECM 100.



2 persons are required for installing the decks and toe boards.

Components

-
- | | |
|-----------|-------------------------------|
| 21 | Tube clip 10 x 60 |
| 30 | Steel Deck EDS |
| 46 | Wall Tie UWT |
| 51 | Guardrail Post EPG |
| 56 | Toe Board UPF |
| 63 | Console Bracket ECM 67 |
| 66 | Protection Roof Connector EPC |
-

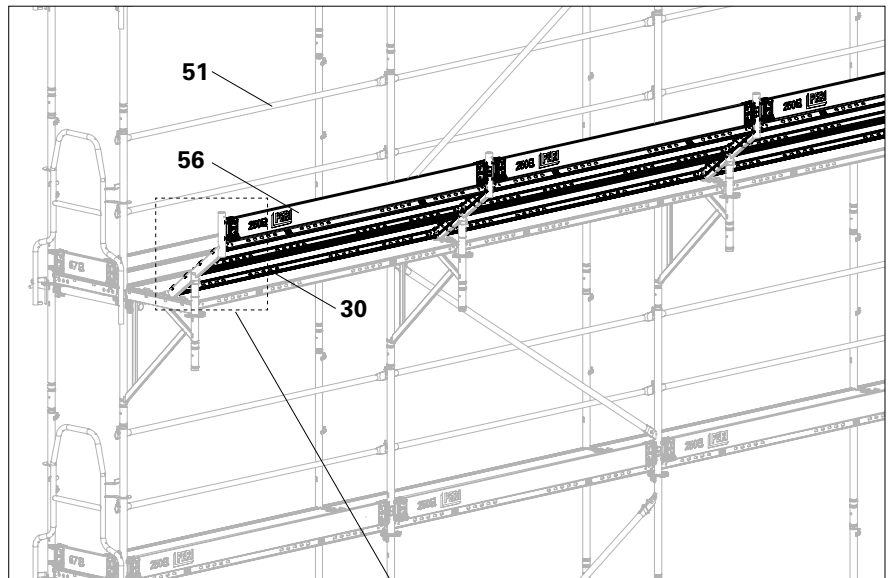

Fig. D4.03

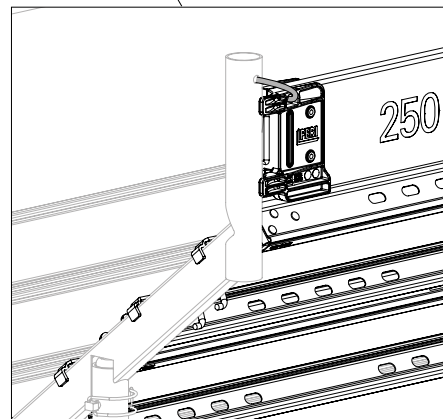

Fig. D4.03a

General

In order to bridge openings, scaffold bays are built over with formwork girders (70), either Steel ULS or Aluminium ULA. Depending on the load, formwork girders with a height of 50 cm or 70 cm can be used individually or in pairs, see Section "Load-bearing capacity of the formwork girders" on page 159 and Section "F3 Bridging" on page 172 or "G3 Formwork girders" on page 228.

Bridging with auxiliary scaffolding



The bridging opening in the scaffold above the erection area must have a clear width of at least 3.5 m and a clear height of 3.5 m.

Installing bridging

1. Install auxiliary scaffolding in order to assemble bridging. To facilitate the removal of the auxiliary scaffolding, set up the auxiliary scaffolding asymmetrically. This will mean that the frame column (A) will be free-standing at a later time. (Fig. D5.01 + D5.01a)

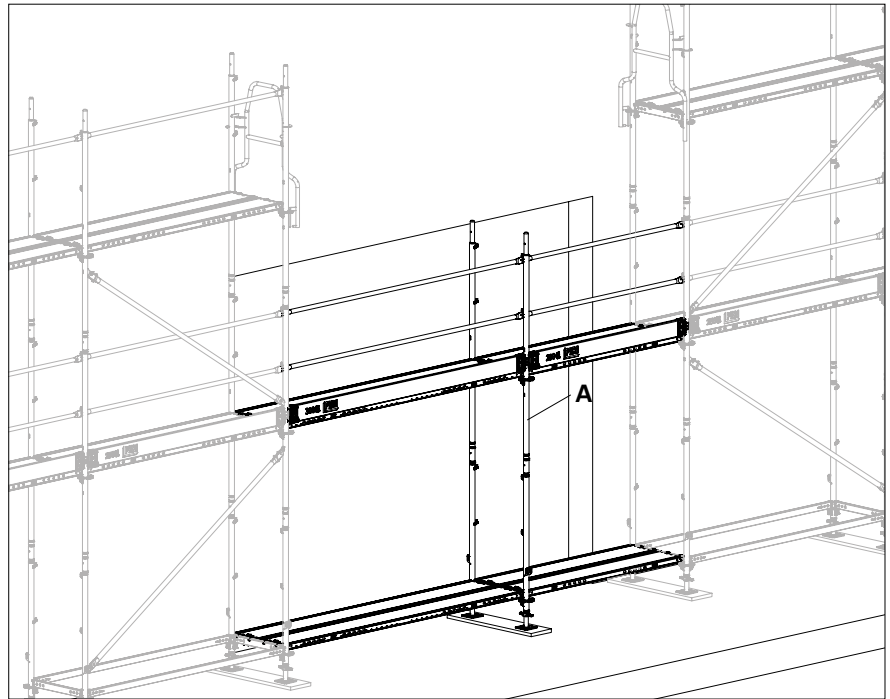

Fig. D5.01

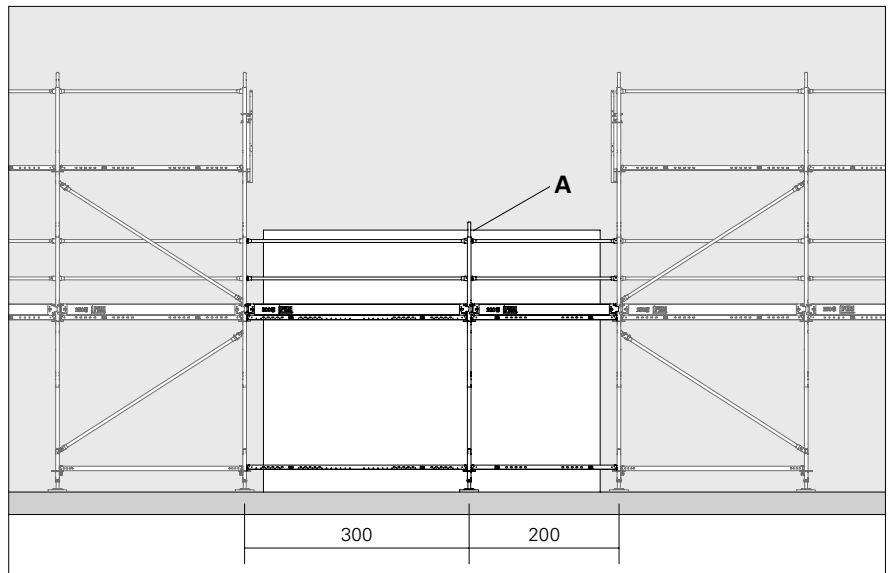

Fig. D5.01a

- From the auxiliary scaffolding:
 - 2. Fit four standard couplers (**48**) onto the inner standard (**22**) and outer leg (**22a**) to the right and left of the opening.
 - Installation height: upper edge of the standard coupler to the lower edge of the rosette of the Easy Standard: 11 cm. (Fig. D5.02a)
 - 3. Position the formwork girder at the installation height and screw the top chord (**70.1**) onto the pre-assembled couplings.
 - 4. Using four additional standard couplers, firmly screw the bottom chords of the formwork girders (**70.2**) in the same way.
- (Fig. D5.02)



Do not deviate from the installation height dimensions of the formwork girder! Inaccuracies lead to reduced load-bearing capacity, as well as wobbly or uneven decking.

Components

-
- 22** Easy Standard EVM 200
 - 48** Standard coupler
 - 70** Formwork Girder ULS/ULA
-

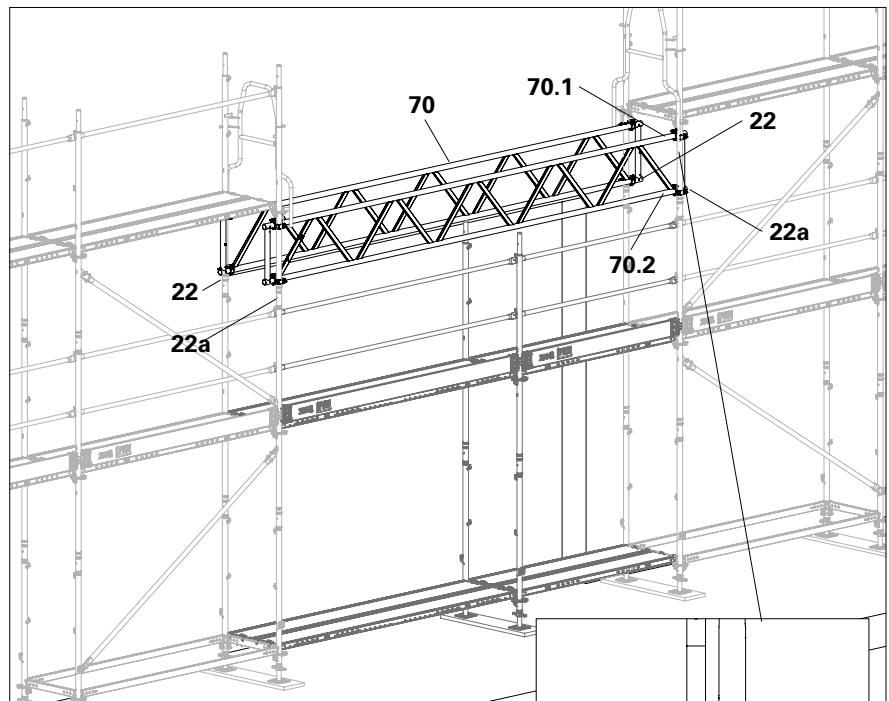

Fig. D5.02

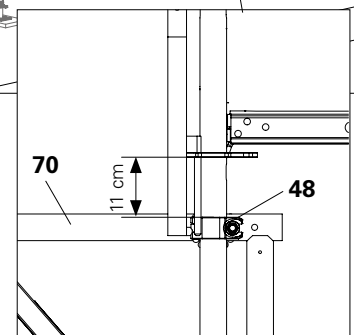

Fig. D5.02a

5. Position Starter Tube ULB (**71**) on the formwork girders (**70**).
6. Insert Easy Base Standards EVS (**23**) into starter tubes and connect them with horizontal ledgers (**98**). Secure the wedges.
7. Install the decks (**30**).
(Fig. D5.03)



Secure the base standards against toppling until all decks are installed.

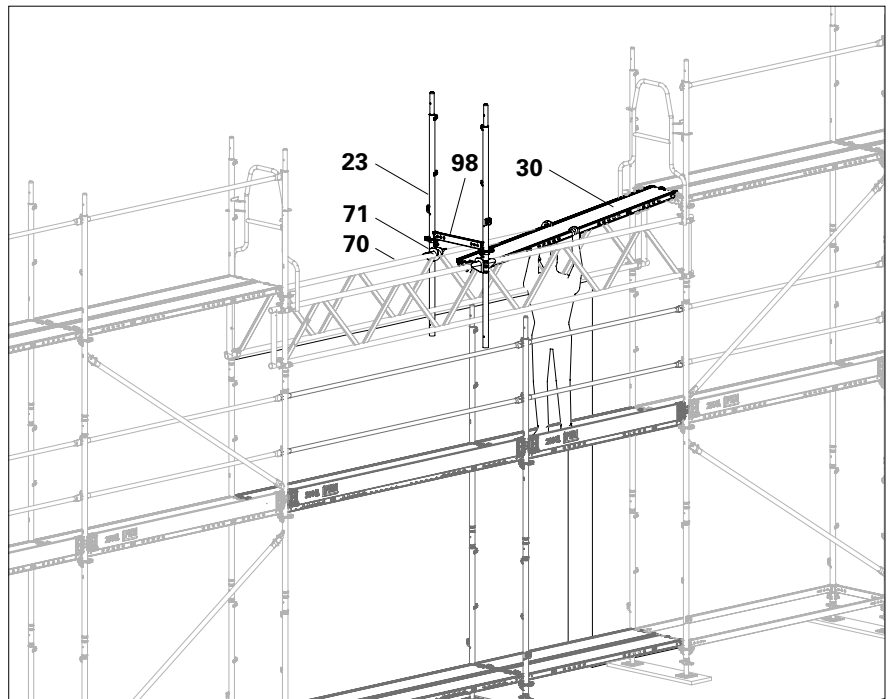

Fig. D5.03

8. Place Coupling Latch UHC 67 (**72**) on both bottom chords (**70.2**) of the formwork girders with the lugs (**72.1**) downwards. Place couplings around the starter tube (**71**), close and tighten.
(Fig. D5.04 + D5.04a)

Components

- | | |
|-----------|----------------------------|
| 23 | Easy Base Standard EVS 124 |
| 30 | Steel Deck EDS |
| 70 | Formwork Girder ULS/ULA |
| 71 | Starter Tube ULB |
| 72 | Coupling Latch UHC |
| 98 | Horizontal Ledger UH-2 67 |



Due to lifting wind forces, mount the Coupling Latch UHC from below.

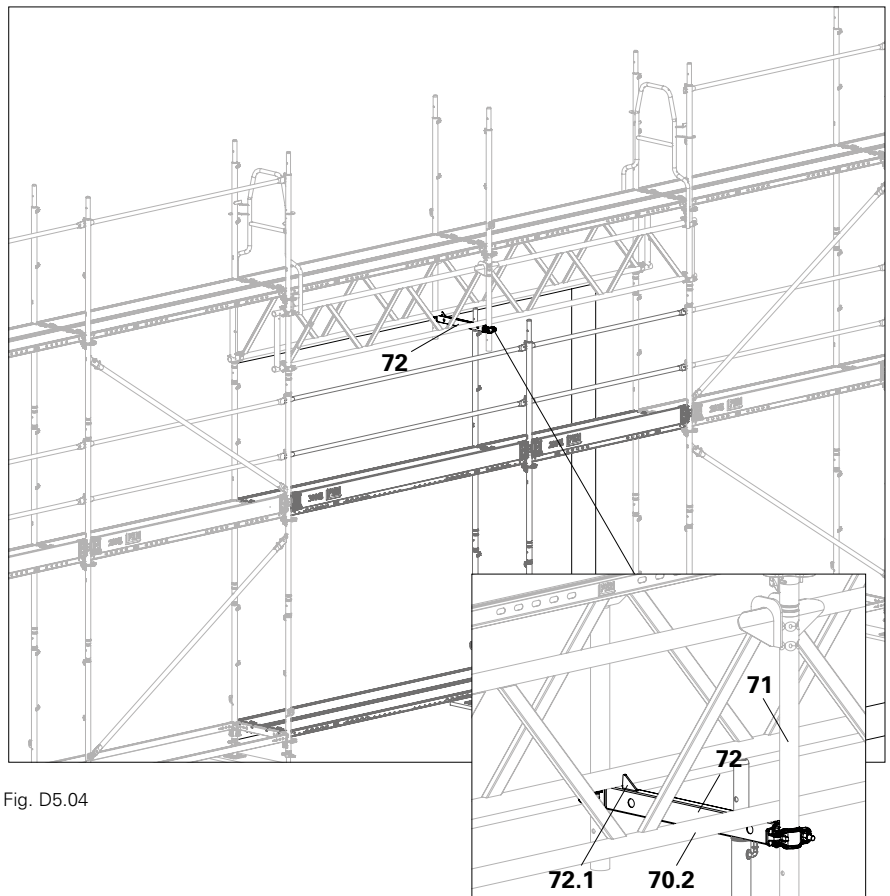

Fig. D5.04

Fig. D5.04a

9. Install the bracing and anchoring from the auxiliary scaffolding (**46**).
See "Bracing and anchoring" on page 138 ff.
(Fig. D5.05)

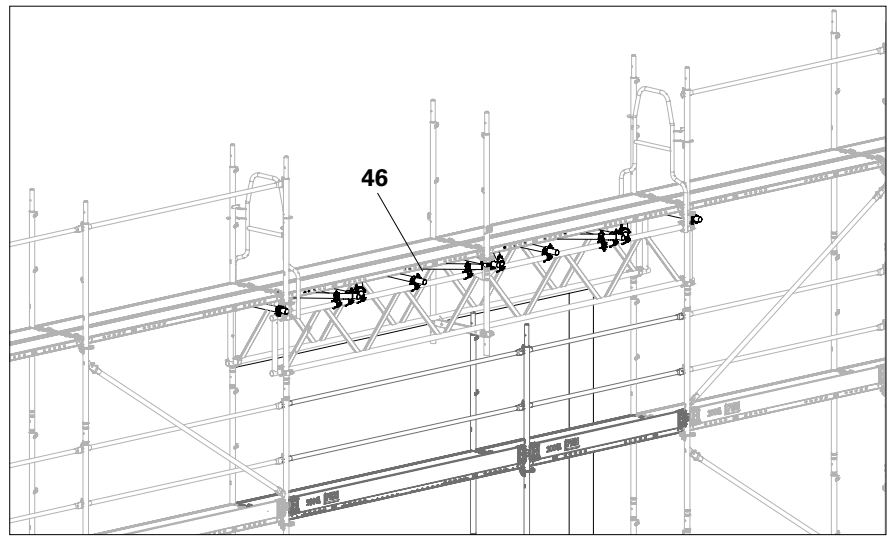

Fig. D5.05

Dismantling the auxiliary scaffolding

1. Install End Guardrail in Advance UPA (**52**) or End Guardrail EPF along the later opening on the basic scaffold.
2. Dismantle the auxiliary scaffolding.
(Fig. D5.06)

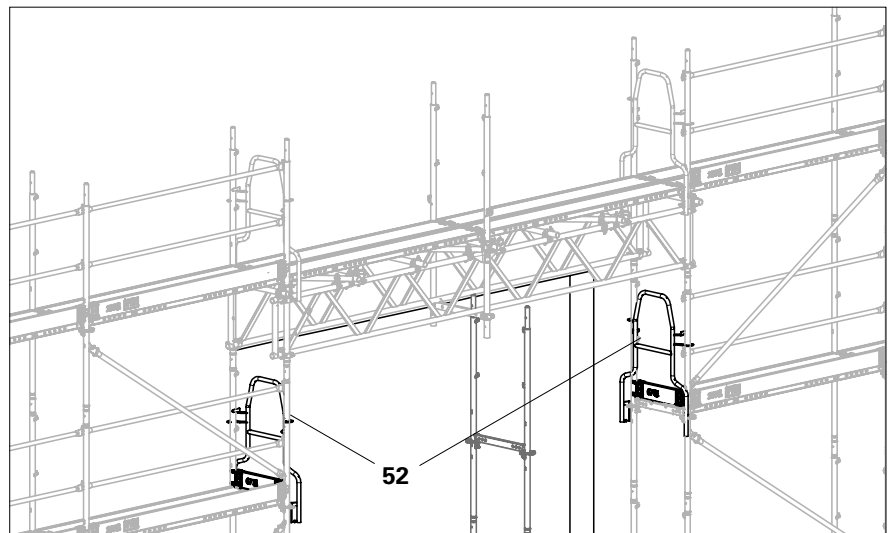

Fig. D5.06

Installing the lateral protection

- From the basic scaffold:
 1. Fit Guardrail Posts EPG (**51**).
 2. Remove End Guardrail in Advance UPA (**52**) from the bridging position.
 3. Complete the lateral protection with intermediate guardrail (**51a**) and Toe Board UPF (**56**).
- The bridging is now installed.
(Fig. D5.07)

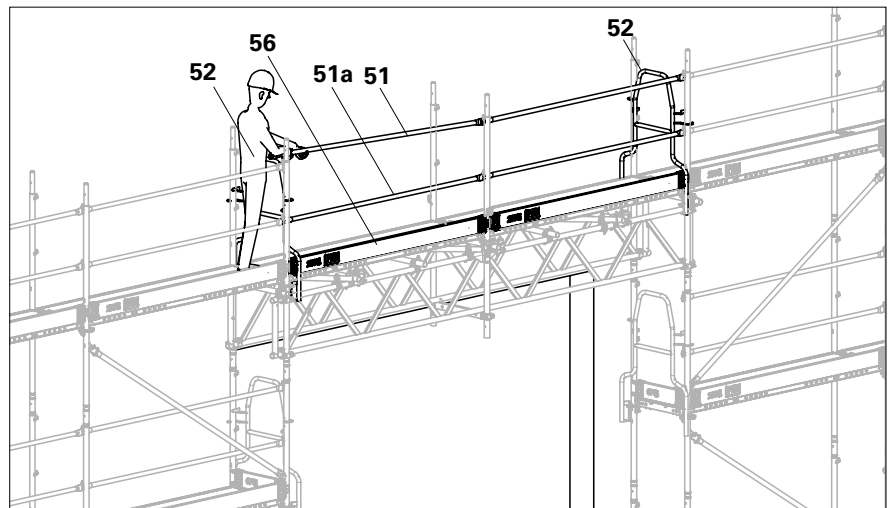

Fig. D5.07

Components

- 46** Wall Tie UWT
- 51** Guardrail Post EPG
- 52** Advance End Guardrail UPA 67
- 56** Toe Board UPF

Bracing and anchoring



The spacings $a_1 - a_3$ of the lateral holders are to be selected according to the load stated in "Load-bearing capacity of the formwork girders" on page 159, whilst ties and braces are installed in accordance with the Section Tie pattern.

Execution in accordance with standard configurations in Section E2.

Variant 1

Bracing with scaffold tubes

Brace the top chords of the Formwork Girders ULS/ULA (70) with a combination of scaffold tubes and swivel couplings.

1. Fit the scaffold tubes (75) onto both top chords (70.1) of the formwork girders with swivel couplings (49) and standard couplers (48).
 2. Attach Wall Tie UWT to the Eyebolt UFE (44).
 3. Fit the Wall Tie UWT (46) onto both Easy Base Standards EVS (23) with standard couplers.
 4. Fit the Wall Tie UWT (46a) onto both Easy Standards EVM (22).
- The bracing is now installed.
(Fig. D5.08 – D5.10)

Section A – A

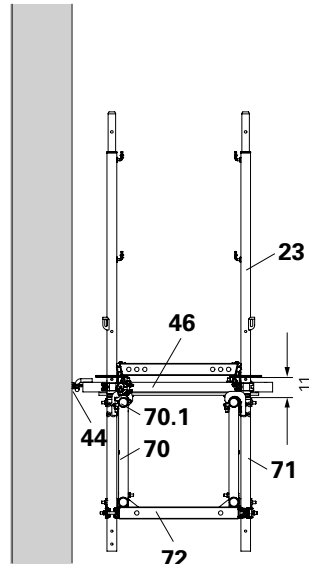

Fig. D5.08

View B

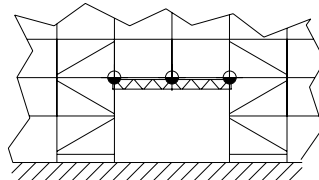

Fig. D5.10

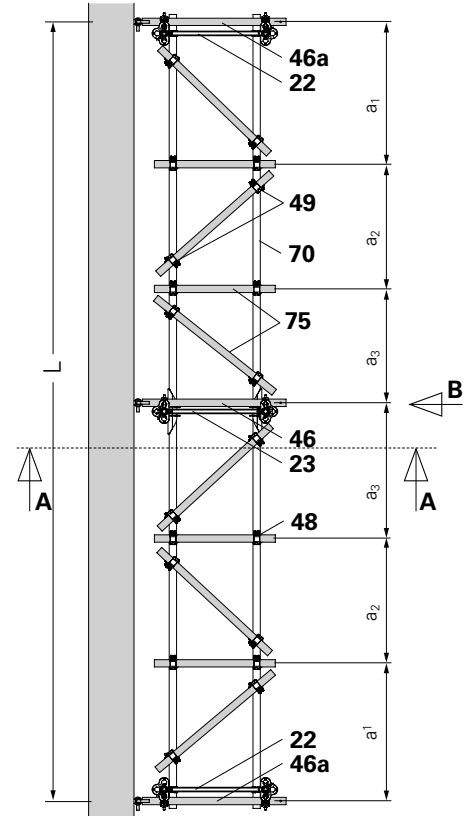

Fig. D5.09

Variant 2

Bracing with Wall Tie UWT

Alternatively, brace the Formwork Girders ULS/ULA (70) with Wall Ties UWT (46) and standard couplers.

1. Attach Wall Tie UWT to the Eyebolt UFE (44).
 2. Fit Wall Ties UWT (46) onto both Base Standards EVS (23) with standard couplers (48).
 3. Fit Wall Ties UWT (46a) onto both top chords of the formwork girders.
 4. Fit the Wall Tie UWT (46b) onto both Easy Standards EVM 200 (22).
- The bracing is now installed.
(Fig. D5.11 – D5.13)

Components

- | | |
|-----------|----------------------------|
| 22 | Easy Standard EVM 200 |
| 23 | Easy Base Standard EVS 124 |
| 44 | Eyebolt UFE |
| 46 | Wall Tie UWT |
| 48 | Standard coupler |
| 49 | Swivel coupling |
| 70 | Formwork Girder ULS/ULA |
| 71 | Starter Tube ULB |
| 72 | Coupling Latch UHC |
| 75 | Scaffold tube |

Section A – A

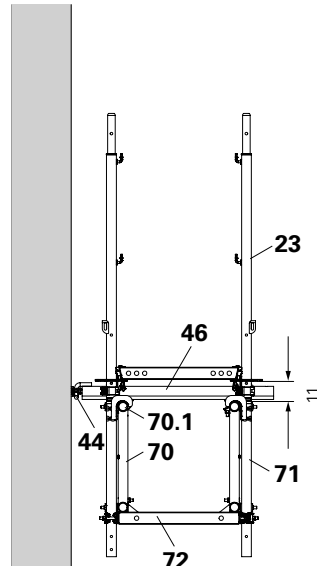

Fig. D5.11

View B

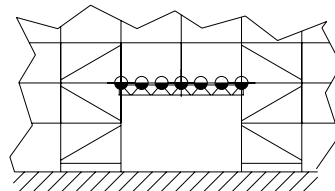

Fig. D5.13

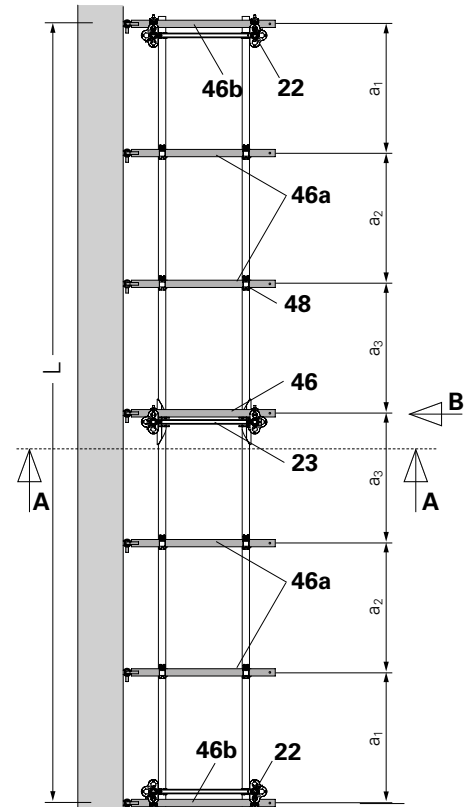

Fig. D5.12

Bridging with 2 x 2 Formwork Girders ULS/ULA

After installing the first formwork girders on the inside, formwork girders can additionally be installed below on the outer side of the vertical tubes with an offset of 12 cm.



- The spacings $a_1 - a_3$ of the lateral holders are to be selected according to the load stated in "Load-bearing capacity of the formwork girders" on page 159, whilst ties and braces are installed in accordance with the Section Tie pattern.
- The permissible loads for bridging with 2 x 2 formwork girders are derived from the sum of the permissible loads of the individual girders.

Variant 1

Bracing with scaffold tubes

1. Brace the internal formwork girders with standard couplers (48) and scaffold tubes (75) beneath the top chords.
2. Attach Wall Tie UWT (46) to the Eyebolt UFE.
3. Place Wall Tie UWT (46) on the top chords of the top formwork girder (70). Fit the Wall Tie onto both Easy Base Standards (23) with standard couplers.
4. Fit the Wall Tie UWT (46a) onto both Easy Standards EVM (22).
5. Fit the formwork girders (70a) that have been shifted downwards onto the scaffold tubes (75) using standard couplers, align them and fit them onto both Easy Standards EVM (22).
6. Slide the scaffold tubes (75a) transversely between the top chords of the formwork girders. Fit the scaffold tubes onto the top chords of the outer formwork girders with swivel couplings (49).

→ The bracing is now installed.

(Fig. D5.14 – D5.16)

Section A – A

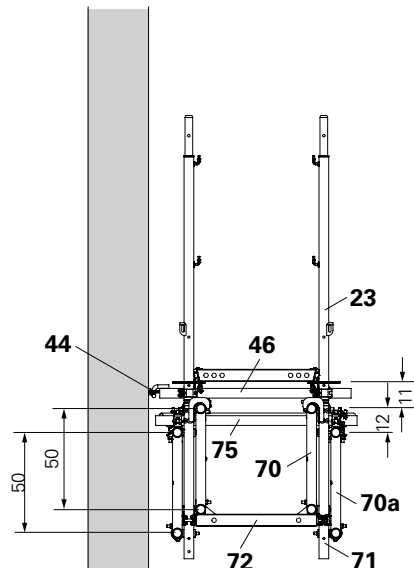

Fig. D5.14

View B

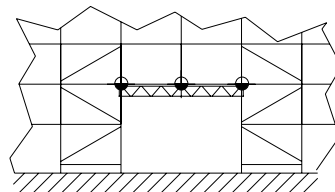

Fig. D5.16

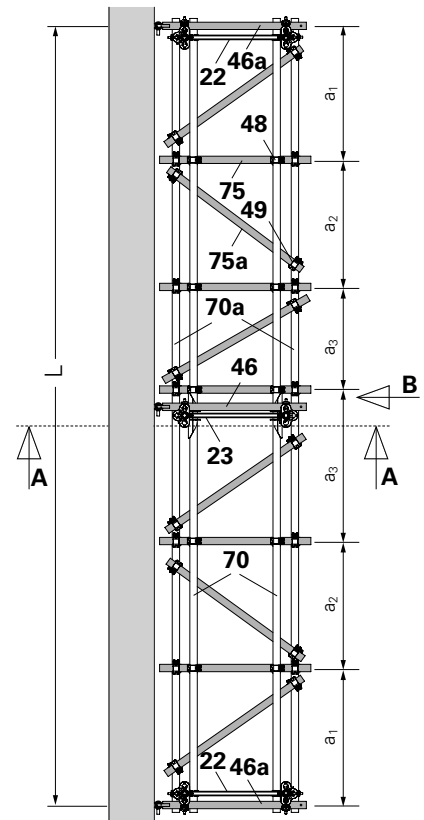

Fig. D5.15

Variant 2

Bracing with Wall Tie UWT

Alternatively, brace the Formwork Girders ULS/ULA (70) with Wall Ties UWT (46) and standard couplers (48).

1. Attach Wall Tie UWT (46) to the Eyebolt UFE.
 2. Place Wall Tie UWT (46) on the top chords of the top formwork girders (70). Fit the Wall Tie UWT onto both Easy Base Standards EVS (23).
 3. Fit Wall Ties UWT (46a) beneath the top chords of the formwork girders (70).
 4. Fit the formwork girders that have been shifted downwards onto the scaffold holders (46a) using standard couplers, align them and fit them onto both Easy Standards EVM (22).
 5. Fit the Wall Tie UWT (46b) onto both Easy Standards EVM (22).
- The bracing is now installed.
(Fig. D5.17 – D5.19)

Components

- | | |
|-----------|----------------------------|
| 22 | Easy Standard EVM 200 |
| 23 | Easy Base Standard EVS 124 |
| 44 | Eyebolt UFE |
| 46 | Wall Tie UWT |
| 48 | Standard coupler |
| 49 | Swivel coupling |
| 70 | Formwork Girder ULS/ULA |
| 71 | Starter Tube ULB |
| 72 | Coupling Latch UHC |
| 75 | Scaffold tube |

Section A – A

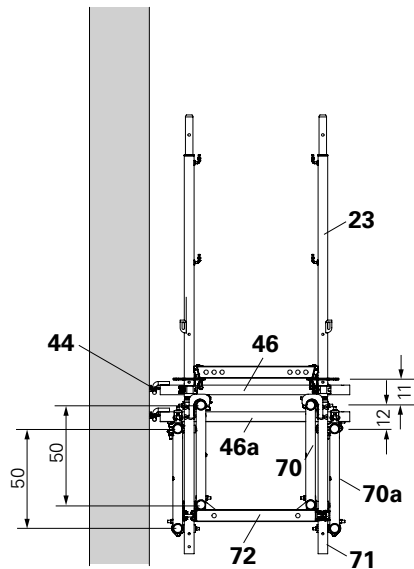

Fig. D5.17

View B

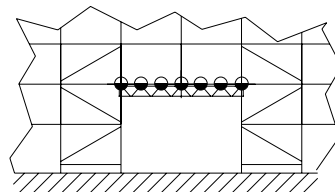

Fig. D5.19

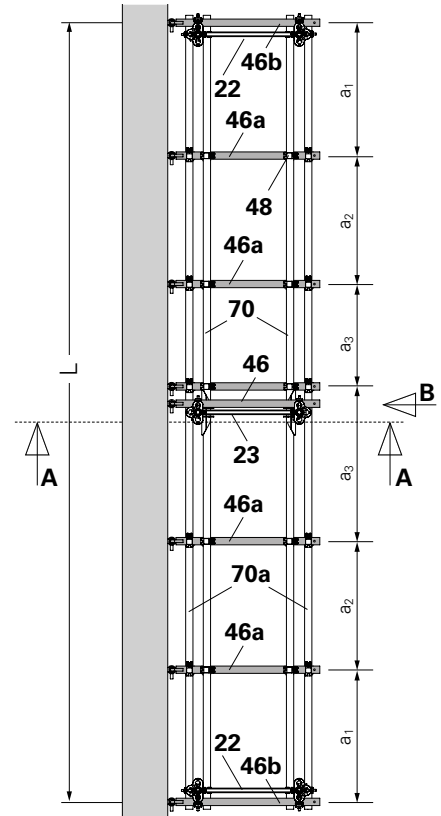

Fig. D5.18

General

Core components for the realisation of pavement gantries are

- Multi Girder ELM 200 (**73**),
- UH-Spigot-2 (**93**),
- Ledger-to-ledger Coupler UHA-2 Half with Spigot (**92**).

(Fig. D6.01)

Adjusting the passage width

The multi girder can be attached to:

- both tube ends on Tube EVR 150, Easy Standards EVM 200 or Standards UVR-2,
- a tube end on Tube EVR 150, Easy Standards EVM 200, or Standards UVR-2 and a UH Spigot-2 (**93**) on Top Standard UVH,
- two UH Spigots-2 on Top Standards UVH.

Use the tube ends of the multi adapter to use the full passage width. For reduced passage widths, attach and securely wedge (**93**) one or two UH Spigots-2 (**93**) to the underside of the Multi Girder ELM (**73**) or connect with bolts M10 x 70 and nuts (**93a**).

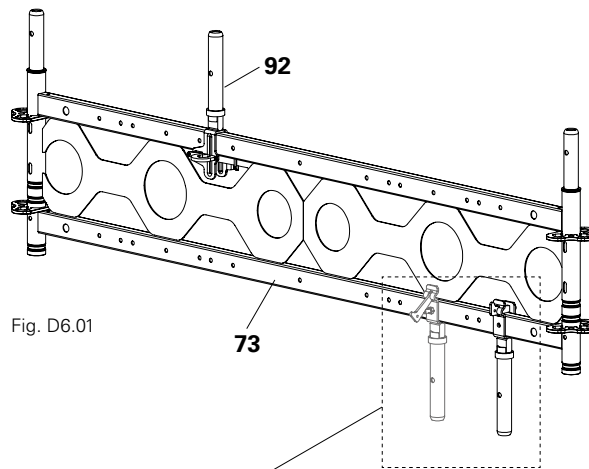
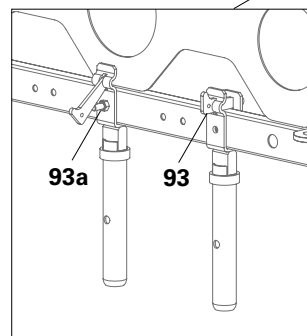

Fig. D6.01



Components

-
- | | |
|-----------|---|
| 73 | Multi Girder ELM 200 |
| 92 | Ledger-to-ledger Coupler UHA-2 half with spigot |
| 93 | UH Spigot-2 |
-

Positioning the scaffold assembly

The scaffold above the pavement gantry can be erected either:

- on an end tube of the multi girder and a Ledger-to-Ledger Coupler UHA-2 half with spigot (92),
- or on two Ledger-to-Ledger Couplers UHA-2 half with spigot (92)

To position the scaffold assembly on the top of the Multi Girder ELM (73), attach the Ledger-to-Ledger Coupler UHA-2 Half with Spigot (92) and wedge it tight.

Possible combinations of pavement gantry widths and working scaffold positions are based on the system width and the construction site requirements (Fig. D6.01a + D6.01b)



- Do not load the Multi Girder ELM or UH Spigot-2!
- Scaffolds in public traffic areas are to be secured according to national legislation and regulations (e.g. traffic signs, barriers, protective components, warning lights, etc.).

Combinations for Easy 67

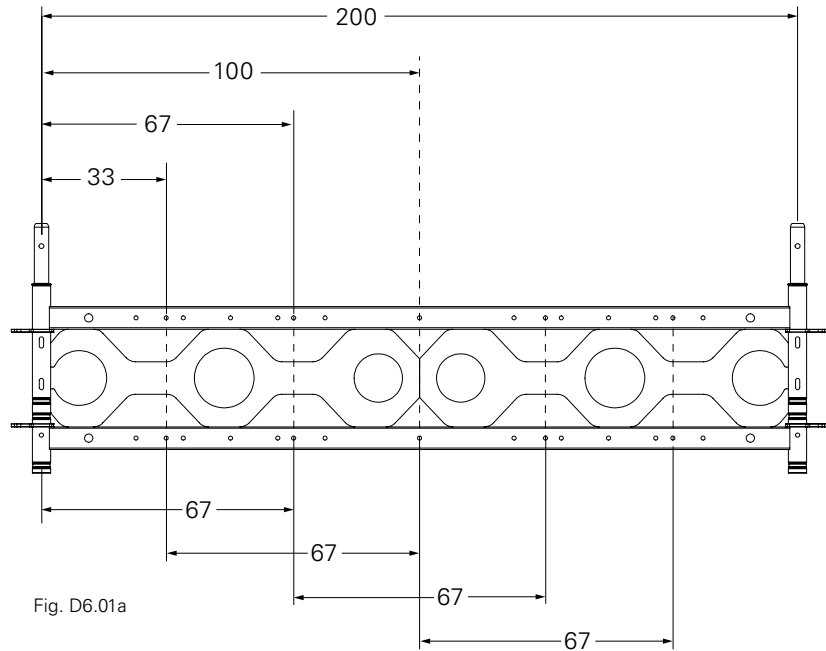

Fig. D6.01a

Combinations for Easy 100

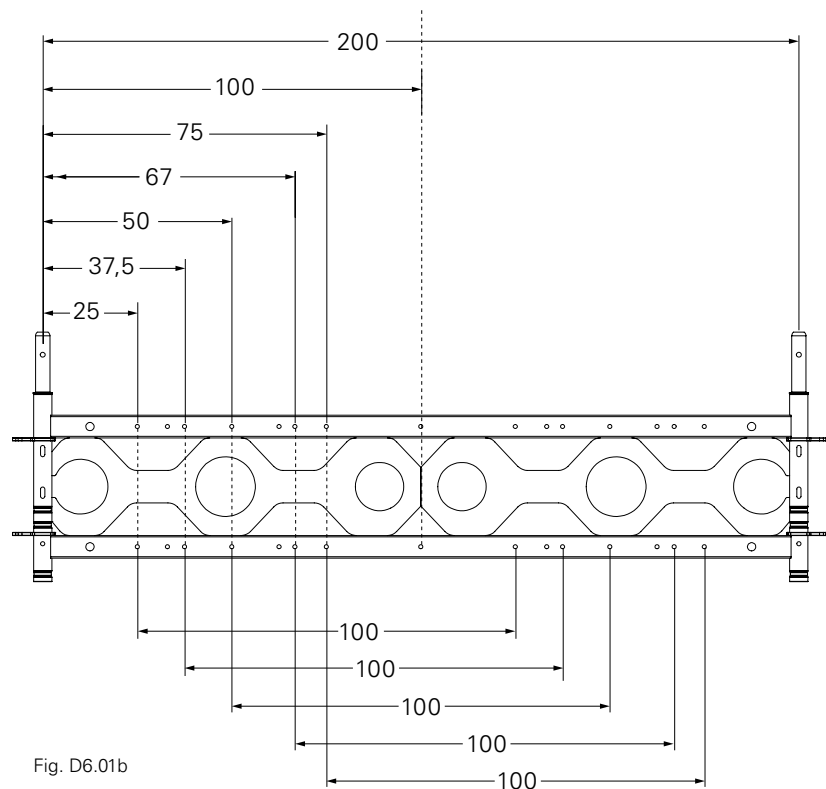

Fig. D6.01b

Adjusting the passage height

Variant 1

The minimum passage height of 2.10 m is realised with 1.50 m long standards (EVR, UVR-2) in connection with base standards.

For this, spindle out Base Spindles UJB 38-50/30 for 30 cm.

Max. spindling length = 35 cm (incl. plate and quick jack nut)

An additional adjustment range of 5 cm is available for ground surface compensation. (Fig. D6.02)

Variant 2

For standards with lengths of 2.00 m, this results in a minimum passage height of 2.35 m with a 5 cm spindling extension range.

The maximum passage height can be adjusted up to 2.90 m.

For this, spindle out Base Spindles UJB 38-80/55 for 60 cm (= max.).

For other combinations, see Table D6.01.



For the maximum extension lengths, see Section Tie pattern

Components

- 10** Base Spindle UJB 38-50/30
- 11** Base Spindle UJB 38-80/55
- 18** Tube EVR 150
- 23** Easy Standard EVM 200
- 30** Steel Deck EDS
- 73** Multi Girder ELM 200
- 80** Base Standard UVB
- 82** Standard UVR-2
- 94** Horizontal Ledger UH-2

Variant 1

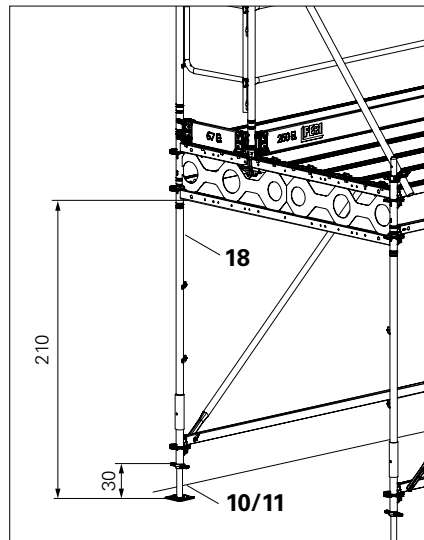

Fig. D6.02

Passage heights			
Standard	Base spindle	Extension range	Passage height
Variant 1 EVR 150 UVR-2 150	UJB 38-50/30	30 cm	2.10 m
	UJB 38-80/55	60 cm	2.40 m
Variant 2 EVM 200 UVR-2 200	UJB 38-50/30	5 cm	2.35 m
		30 cm	2.60 m
	UJB 38-80/55	60 cm	2.90 m

Tab. D6.01

Assembling pavement gantries



- Follow the assembly sequence!
- Quantity and positions of ties, bracing with Horizontal Ledgers UH-2, Face Braces EBF and Ledger Braces UBL, see Section Tie pattern.

Horizontal pre-assembly of frame columns

- Spindle out Base Spindles UJB 38-50/30 (10) sufficiently so as to realise the required clear passage height.
- Connect base spindle to Base Standard UVB 25 (80), Tube EVR 150 (18) and the prepared Multi Girder ELM.
- Fit additional frame columns. (Fig. D6.03)

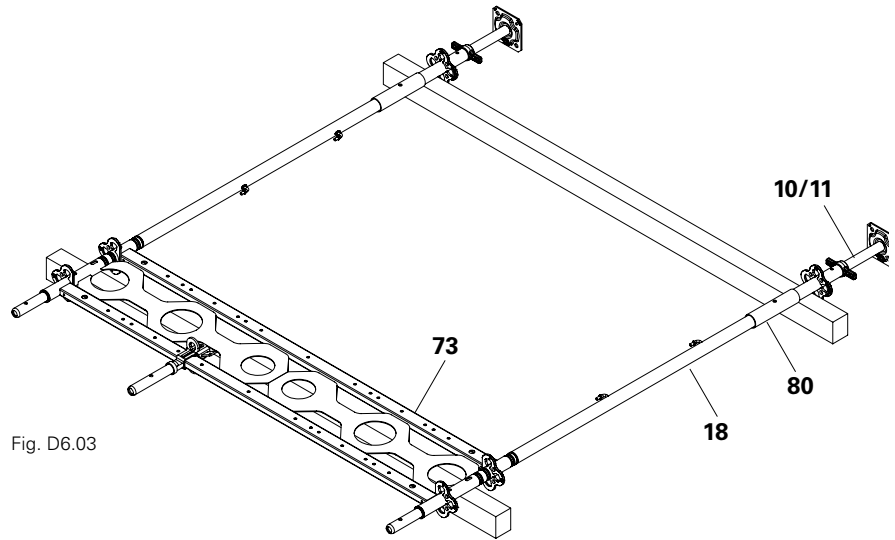

Fig. D6.03



- Alternatively, the Standard UVR-2 150 can be used.
- For larger passage heights, use Easy Standard EVM 200 or UVR-2 200.



Be mindful of loose components during the erection process!

Setting up the first bay

- Set up frame columns and connect them to the base standard using Horizontal Ledgers UH-2 (94).
- Horizontally align the frame columns using a spirit level and securely fix the wedges.
- Fit Horizontal Ledger UH-2 (94a) as an assembly aid on the base level and attach the decks (30). (Fig. D6.04)

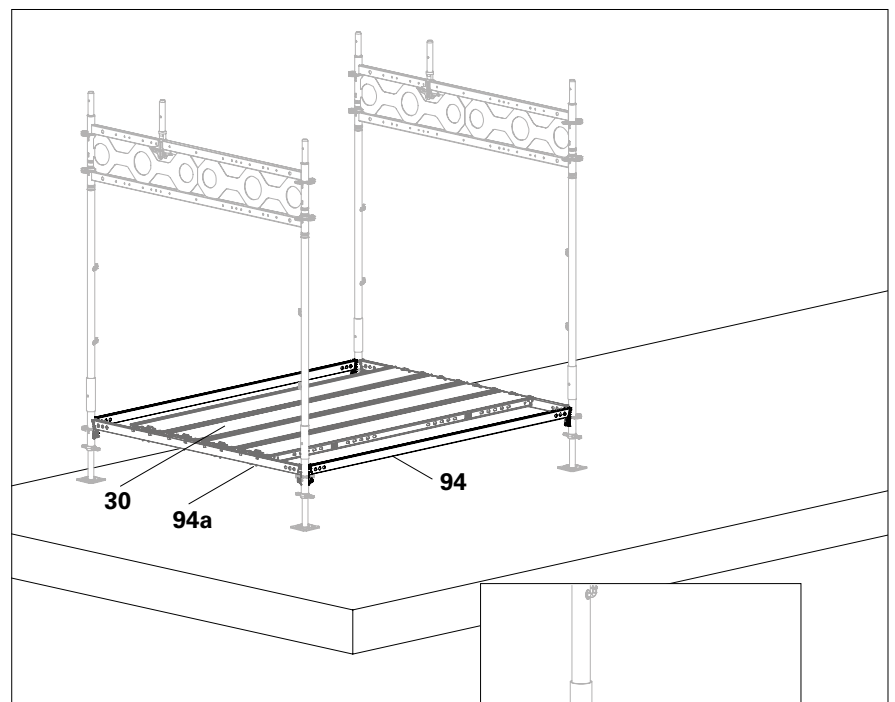

Fig. D6.04

4. Connect frame columns to the inner and outer sides of the scaffold with Horizontal Ledgers UH-2 (**94**):
 - to rosettes (**73.1**) of the Multi Girder ELM.
 - to pre-assembled Ledger-to-Ledger Couplers UHA-2 half with spigots (**92**).
 - Hammer all wedges into place.
5. Install Ledger Braces UBL (**99**) on the inner and outer sides of the pavement gantry. Firstly, insert the mounting finger above and then the gravity pin below.

(Fig. D6.05)



All tilt fingers (**99.1**) of the superstructure must be transverse after installation of the Ledger Braces UBL and rest on both sides of the hole (Fig. D6.05a)

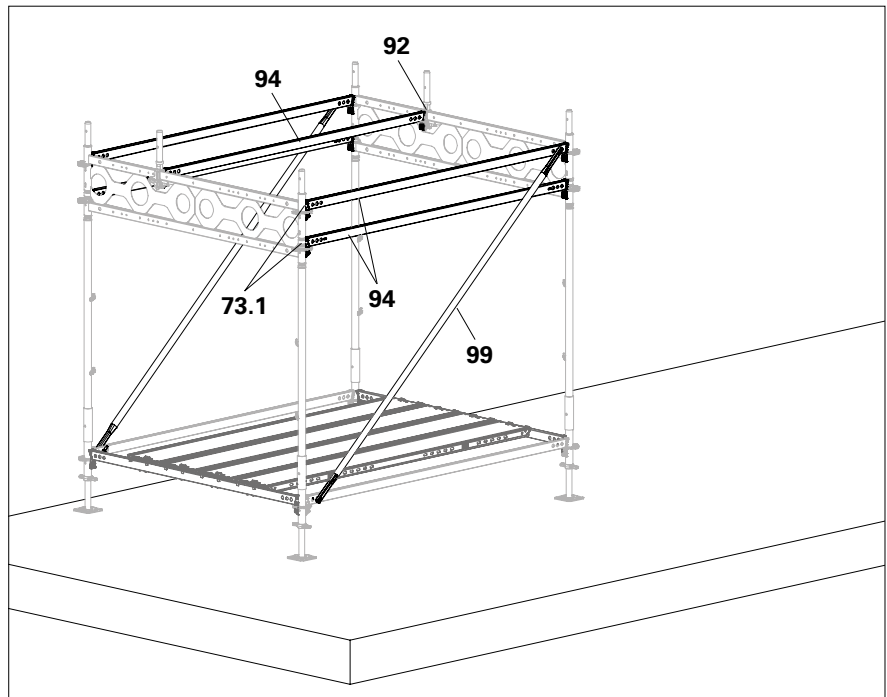

Fig. D6.05

Components

- | | |
|-----------|---|
| 30 | Steel Deck EDS |
| 73 | Multi Girder ELM 200 |
| 92 | Ledger-to-ledger Coupler UHA-2 half with spigot |
| 94 | Horizontal Ledger UH-2 |
| 99 | Ledger Brace UBL-2 |

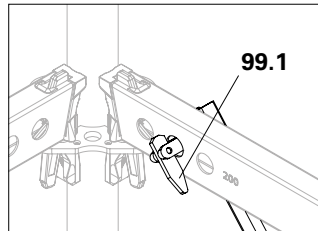

Fig. D6.05a

Erecting additional bays

1. Set up additional frame columns and brace with Horizontal Ledgers UH-2 (94). See work steps for setting up the first bay.
2. Brace every second bay on the base level with Horizontal Ledgers UH-2 (94a).
3. If required, install Ledger Braces UBL.
4. Fit Horizontal Ledger UH-2 (94b) as an assembly aid on the base level and attach the decks (30). (Fig. D6.06)



From a static point of view, Horizontal Ledgers UH-2 and Ledger Braces UBL are not always required, see Section Tie pattern.

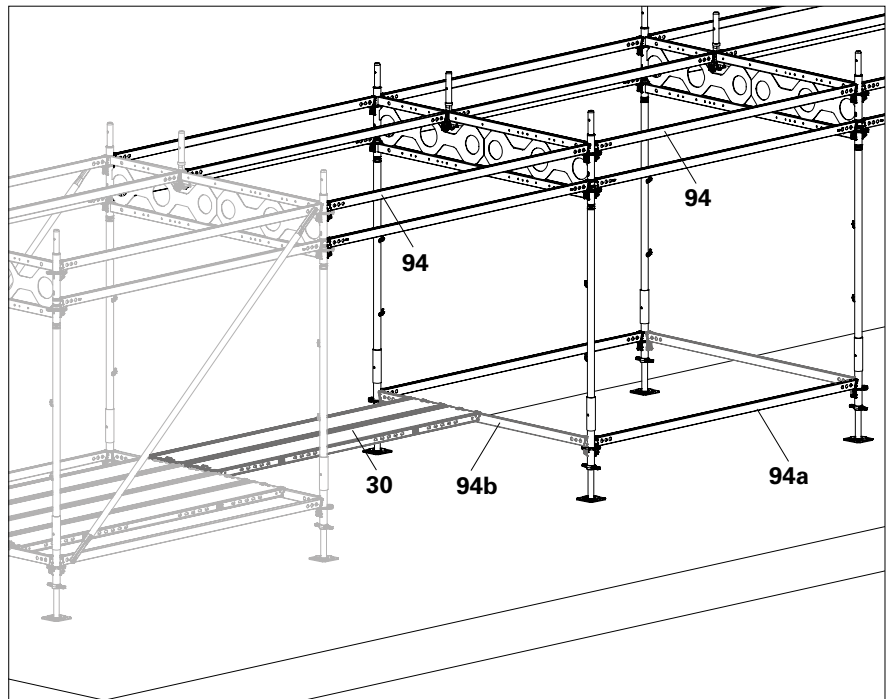

Fig. D6.06

5. Place Steel Decks EDS (30) in the Multi Girder ELM; to do so, gradually start to use the auxiliary decks no longer required in the base level.
6. Remove the Horizontal Ledgers UH-2 (94b), which served as a support for the auxiliary decks, on the base level. → The pavement gantry is now installed. (Fig. D6.07)

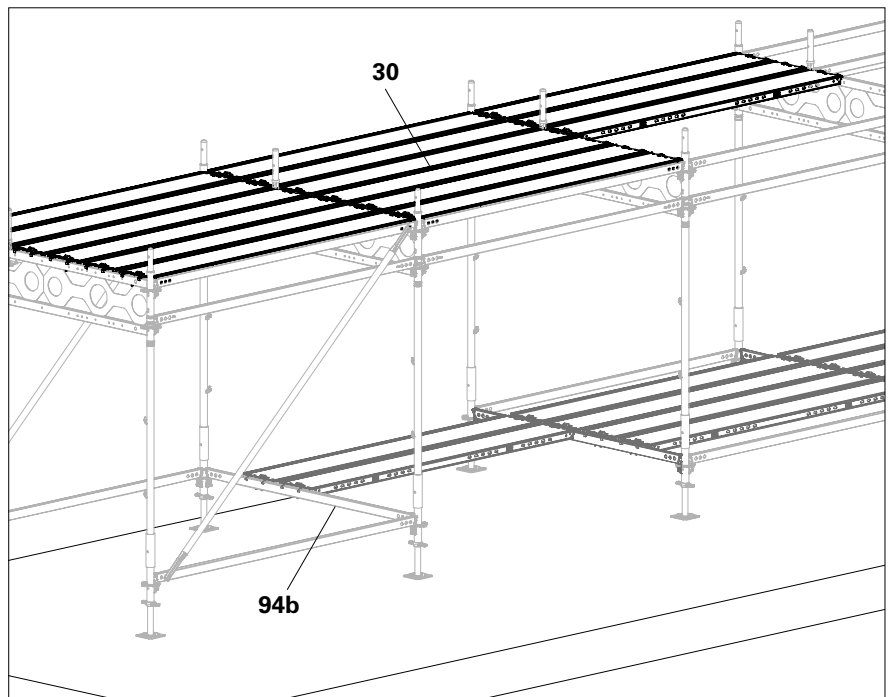

Fig. D6.07

Scaffold assembly



Warning

When walking on the pavement gantry, there is a risk of falling. A fall can result in serious injury.

⇒ Take appropriate measures to prevent falls, e.g. install guardrails.

Variant 1

Assembly with the base frame

1. Fit two Easy Base Standards EVS (23) onto each frame column and connect them with horizontal ledgers (98).
 2. Scaffold erection continues as described in Sections "B2" – "B3".
 3. Brace every frame column with scaffold tubes (75), swivel couplings (49) (49.1) and wall ties (46).
 4. Scaffold erection continues in accordance with Section "B4".
- The scaffold assembly is now installed.

(Fig. D6.08 + D6.08a)

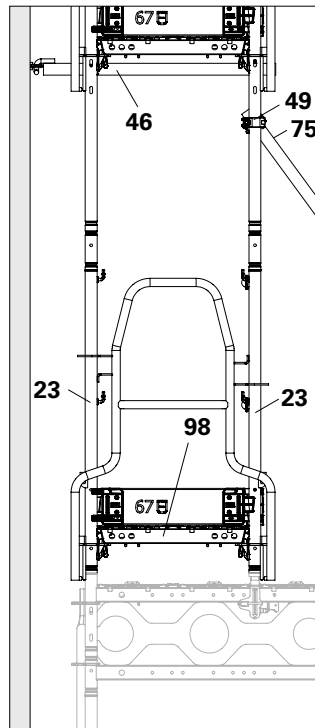

Fig. D6.08a

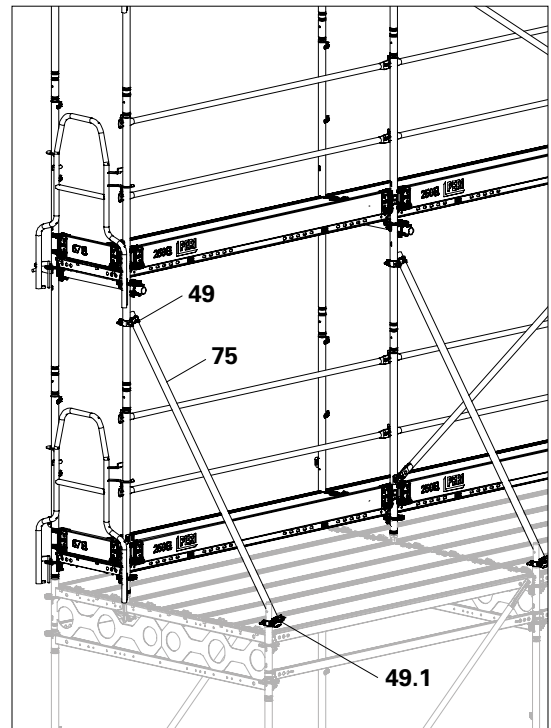

Fig. D6.08



For the quantity and positions of ties, bracing with Horizontal Ledgers UH-2 and braces, see the Section Tie pattern.



The assembly of the additional deck level on the scaffold protects any weather-resistant sheeting that may have been installed on the pavement gantry.

Components

- | | |
|-------------|----------------------------|
| 23 | Easy Base Standard EVS 124 |
| 46 | Wall Tie UWT |
| 49 | Swivel coupling 48/48 |
| 49.1 | Swivel coupling 38/48 |
| 75 | Scaffold tube |
| 98 | Horizontal Ledger UH-2 67 |

Variant 2

Continue immediately with assembly on the multi girder ELM

1. On every frame column:
 - Attach the Guardrail Post EVP (50) to the Ledger-to-Ledger Coupler UH half with spigot (92). Fit the second guardrail post (50a) onto the multi girder (73).
 - Fit Guardrail Posts EPG (51) onto the Guardrail Post EVP (50).
 - Fit Toe Board UPF (56).
 2. Attach End Guardrail EPF (54) to first and last scaffold bays.
 3. Fit Easy Standards EVM 200 (22) onto all guardrail posts and connect them with horizontal ledgers (98).
 4. Scaffold erection continues as described in Sections "B2" – "B3".
 5. Brace every frame column with scaffold tubes (75), swivel couplings (49) (49.1) and wall ties (46).
 6. Fit a brace onto Guardrail Post EVP using Brace Adapter EBA (24). (Fig. D6.09b)
 7. Scaffold erection continues in accordance with Section "B4".
- The scaffold assembly is now installed.
(Fig. D6.09 + D6.09a)

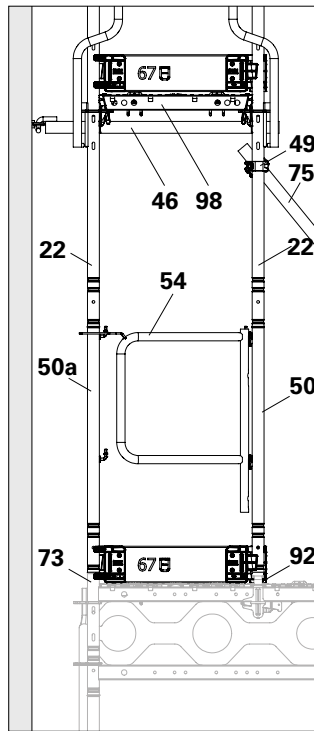

Fig. D6.09a

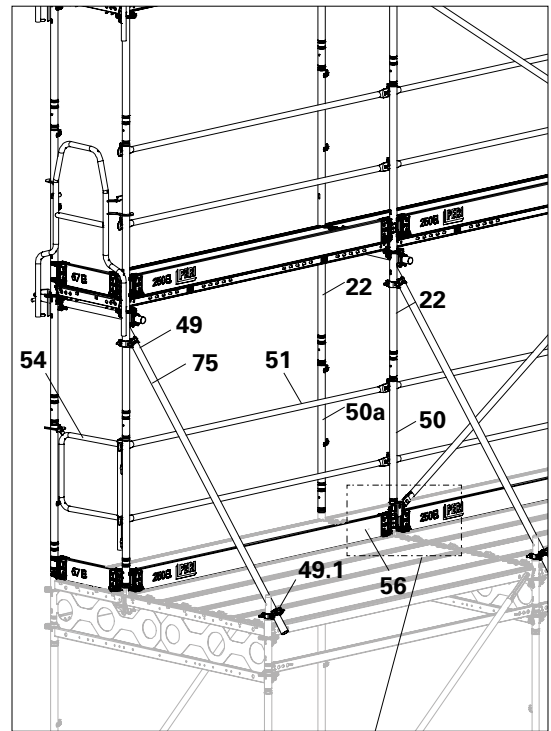

Fig. D6.09



For the quantity and positions of ties, bracing with Horizontal Ledgers UH-2 and braces, see the Section Tie pattern.

Components

- | | |
|-------------|---------------------------|
| 22 | Easy Standard EVM 200 |
| 24 | Brace Adapter EBA |
| 46 | Wall Tie UWT |
| 49 | Swivel coupling 48/48 |
| 49.1 | Swivel coupling 38/48 |
| 50 | Guardrail Post EVP |
| 51 | Guardrail Post EPG |
| 54 | End Guardrail EPF |
| 56 | Toe Board UPF |
| 75 | Scaffold tube |
| 98 | Horizontal Ledger UH-2 67 |

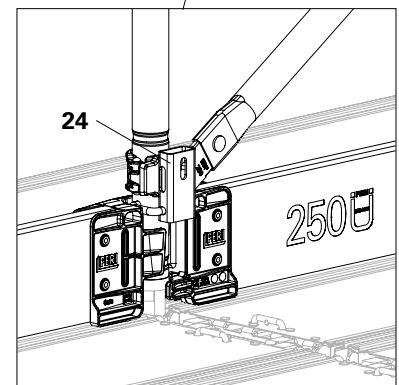

Fig. D6.09b

Multi Brace EWB

On structures that do not allow anchoring, Multi Braces EWB can be installed as scaffold support.

A multi brace consists of:

- An outer tube Ø 60 mm (25.1) with swivel couplings fixed on both sides (25.3, 25.4)
 - Inner tube Ø 48 mm (25.2).
- (Fig. D7.01)



- Maximum extension length 5.60 m. The second hole (25.6) in the inner tube must not be visible and must always be completely covered by the outer tube. (Fig. D7.01)
- Tighten couplings using 50 Nm.
- Attach scaffolding support on each frame column progressively in line with basic scaffold assembly. Support angle $\alpha \leq 60^\circ$.
- The force application must be close to the horizontal ledger. (Fig. D7.01a)

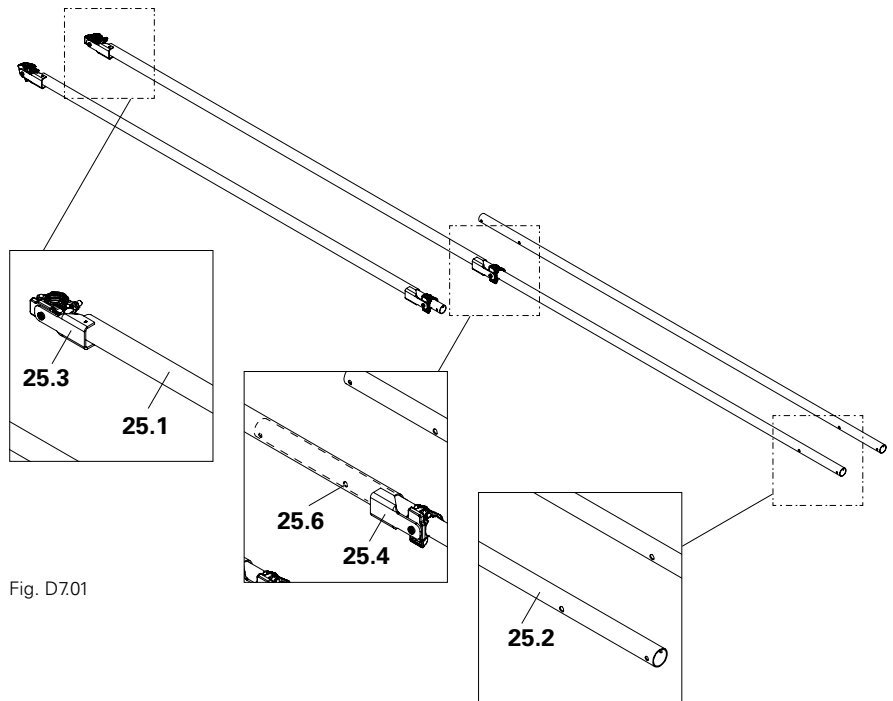

Fig. D7.01

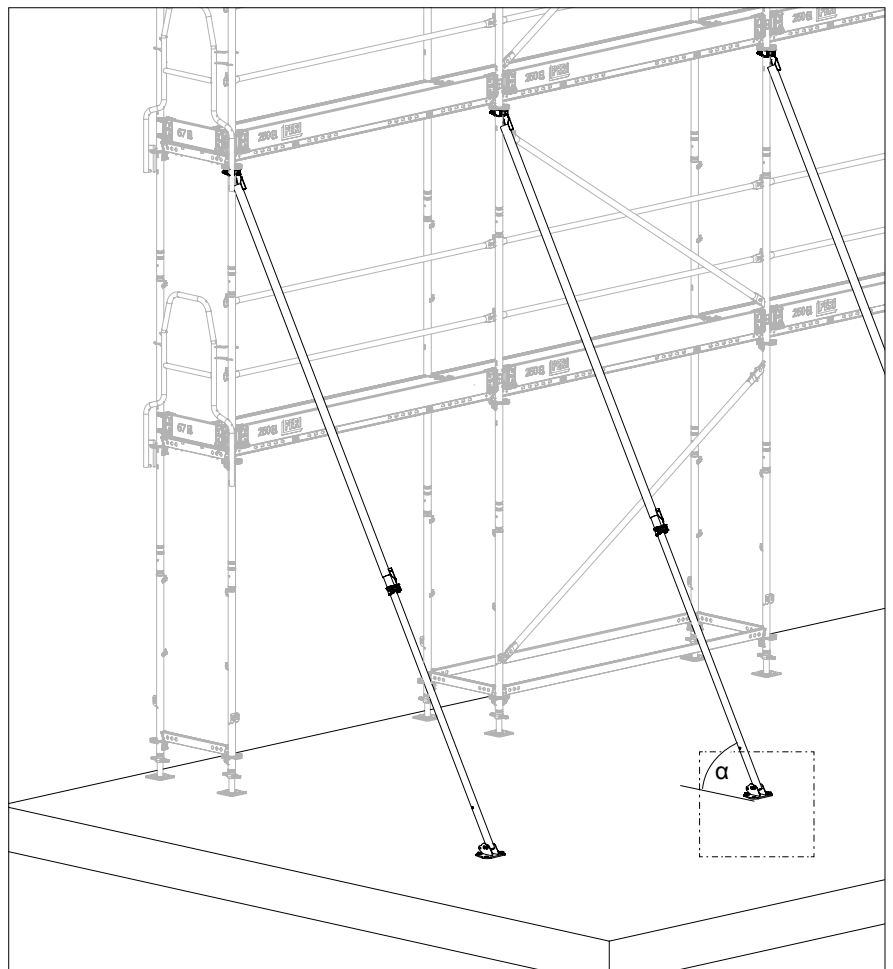

Fig. D7.01a

Base Plate EWB

Fix the Base Plate (**26**) to the substrate using 2 tie bolts (**29**) inserted through the small holes (**26.1**).

Alternatively, fix the base plate to the substrate by means of 2 pegs through the large holes (**26.2**).

Base plate is suitable for standard ground nails up to $d = 25 \text{ mm}$. The hole (**26.2**) of the base plate has a diameter of 28 mm.

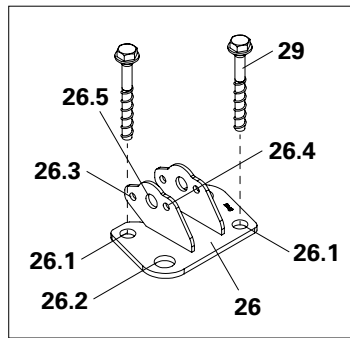

Fig. D7.02

Mount the inner tube of the multi brace on the holes using bolts and nuts (**26.3**) and (**26.4**). If necessary, install a multi brace as a kicker brace at the hole (**26.3**).

(Fig. D7.02)

Instead of the Multi Brace EWB, one Push-Pull Prop RS can be installed on the middle hole (**26.5**) as scaffolding support.

(Fig. D7.03)

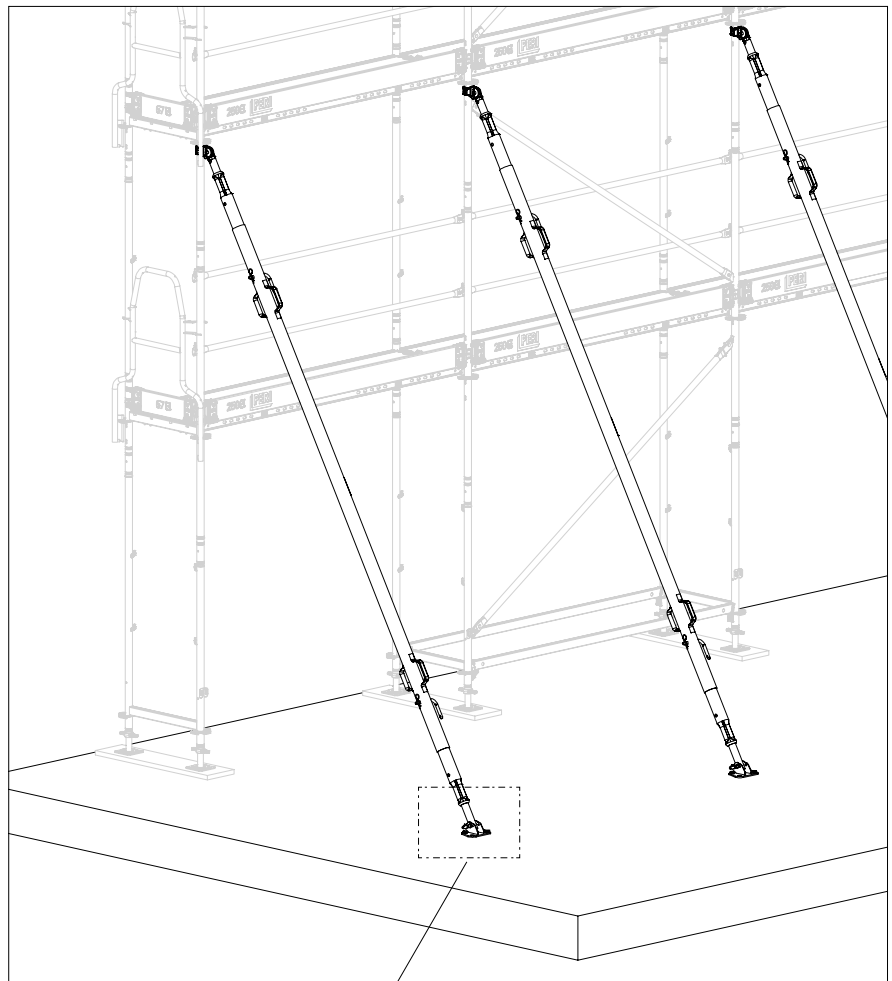
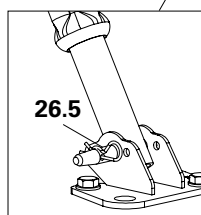

Fig. D7.03



Support on the second scaffold level

Maximum permissible forces at maximum extension of 5.60 m:

Tension: 6.00 kN
 Compression: 3.73 kN

Assembly

1. Secure the multi brace on the basic scaffold at the top with an outer tube (25.1).
2. From the first scaffold level, fit the top coupling (25.3) onto the outer Easy Standard (22). Push the coupling as close as possible to the rosette and tighten. (Fig. D7.04a)
3. Loosen the bottom coupling (25.4) and extend the multi brace until the required support angle of $\alpha \leq 60^\circ$ has been reached. Tighten the bottom coupling. (Fig. D7.04b)
4. Fit the inner tube (25.2) onto the rear hole (26.4) of the base plate by means of bolts (27) and nuts (28).
5. Fix Base Plate EWB (26) to the substrate. (Fig. D7.04c)
6. Label the multi brace as an obstacle.
 → The multi brace is now installed (Fig. D7.04)

Components

22	Easy Standard EVM 200
25	Multi Brace EWB
26	Base Plate EWB
27	Bolt M10 x 80-8.8
28	Nut EN 1661 M10-8
29	Tie Bolt PERI 14/20 x 130

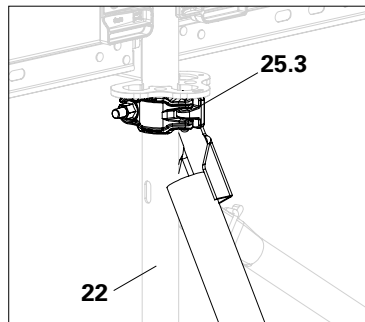

Fig. D7.04a

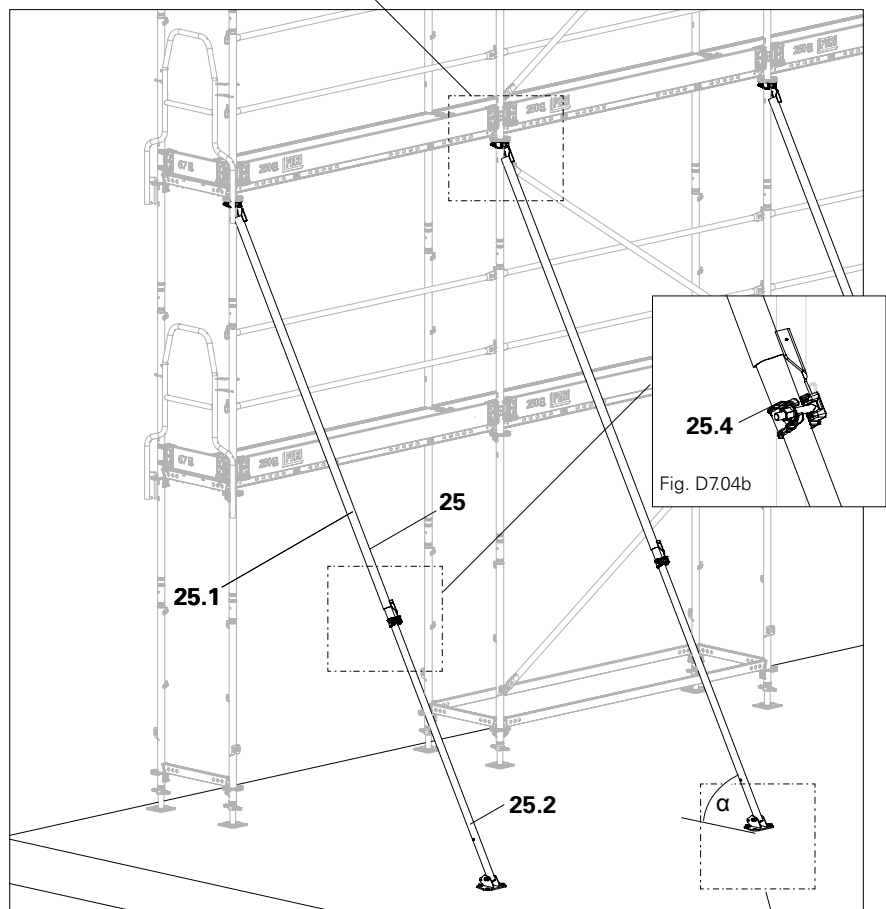

Fig. D7.04

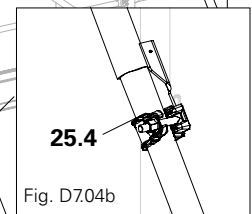

Fig. D7.04b

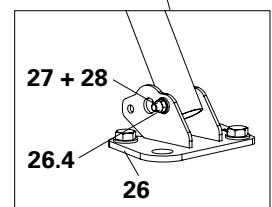

Fig. D7.04c

Support on the third scaffold level

To extend the multi brace, insert another inner tube into the top side of the outer tube.

Maximum permissible forces at maximum extension of 8.20 m:

Tension: 6.00 kN
 Compression: 1.31 kN

Assembly

1. Extend the Multi Brace EWB with an additional inner tube (25.5).
2. Insert upper inner tube (25.5) up to above the second hole in the outer pipe and tighten the coupling.
3. Secure the multi brace on the basic scaffold.
4. From the second scaffold level, fit the inner tube onto the outer Easy Standard (22) using a swivel coupling (49). Push the coupling as close as possible to the rosette and tighten. (Fig. D7.05a)
5. Loosen the bottom coupling and extend the multi brace until the required support angle of $\alpha \leq 60^\circ$ has been reached. Tighten the bottom coupling.
6. Fit the inner tube (25.2) onto the rear hole (26.4) of the base plate by means of bolts (27) and nuts (28).
7. Fix Base Plate EWB (26) to the substrate. (Fig. D7.05b)
8. Label the multi brace as an obstacle.
 → The multi brace is now installed (Fig. D7.05)

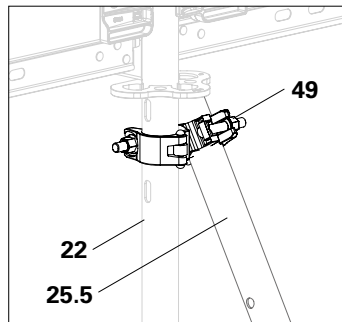

Fig. D7.05a

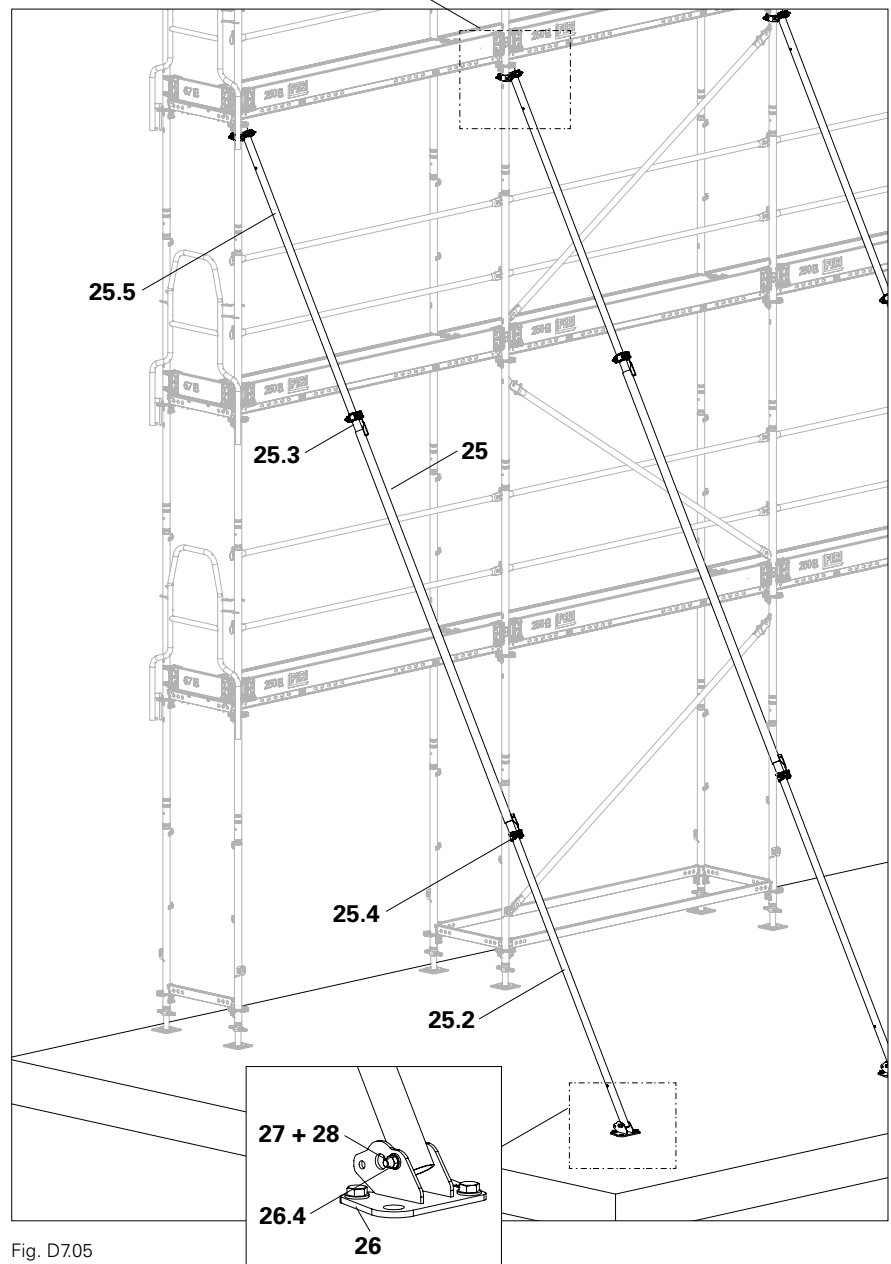

Fig. D7.05

Fig. D7.05b

Bracing

At right angles to the basic scaffold

In special cases, it may be necessary to reinforce the multi brace by means of a ledger, e.g. if the base plate cannot be sufficiently secured to prevent horizontal kicker brace.



- Separate static proof is required!
- The vertical load-bearing capacity of the substrate beneath the base plate must always be ensured!

Assembly

1. Fit an inner tube (**25.2**) onto the front hole (**26.3**) of the base plate (**26**) by means of bolts (**27**) and nuts (**28**). (Fig. D7.06b).
 - Alternatively, fit scaffold tube (**75**) onto the multi brace (**25**) by means of a swivel coupling.
2. Install the inner tube or scaffold tube on the outer base standard (**23**) with a swivel coupling (**49**). Tighten the swivel coupling. (Fig. D7.06a)
3. Label horizontal bracing as an obstacle.
 - The bracing is now installed. (Fig. D7.06)

Required length of the scaffold tube:
 for support on the second scaffold level
 2.50 m,
 for support on the third scaffold level
 4.00 m.

Components

- | | |
|-----------|----------------------------|
| 23 | Easy Base Standard EVS 124 |
| 25 | Multi Brace EWB |
| 26 | Base Plate EWB |
| 27 | Bolt M10 x 80-8.8 |
| 28 | Nut EN 1661 M10-8 |
| 48 | Standard Coupler RA 48/48 |
| 49 | Swivel Coupling AF 48/48 |
| 75 | Scaffold tube |

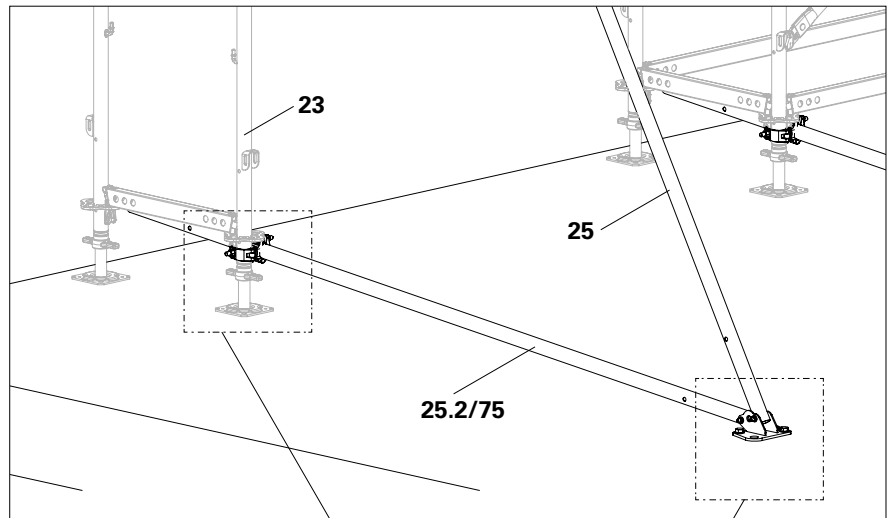

Fig. D7.06

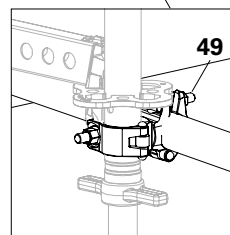

Fig. D7.06a

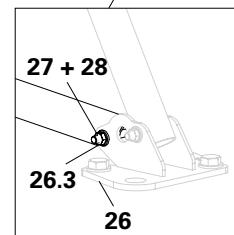

Fig. D7.06b

Horizontal and vertical bracing

If statically required, the multi brace must be reinforced against vertical and horizontal displacement.



- Separate static proof is required!
- The vertical load-bearing capacity of the substrate beneath the base plate must always be ensured!

Assembly

1. Vertically reinforce the multi brace (25) with an outer tube (25.1). Fit the outer tube onto the base standard (23) (Fig. D7.07b) and onto the inner tube (25.2), close to the outer tube. The assembly position has an impact on the support angle.
2. For 3 m long bays, horizontally reinforce each multi brace with an outer tube. For bay lengths ≤ 2.5 m, horizontally reinforce each multi brace with a scaffold tube (75) and standard couplers (48). (Fig. D7.07a)
3. Label horizontal bracing as an obstacle.
→ The bracing is now installed. (Fig. D7.07)

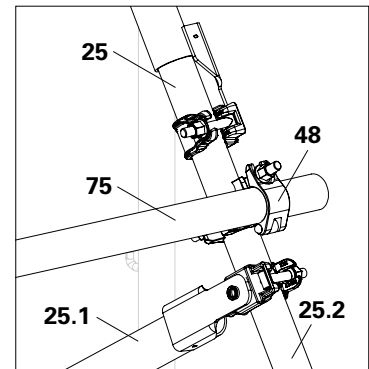

Fig. D7.07a

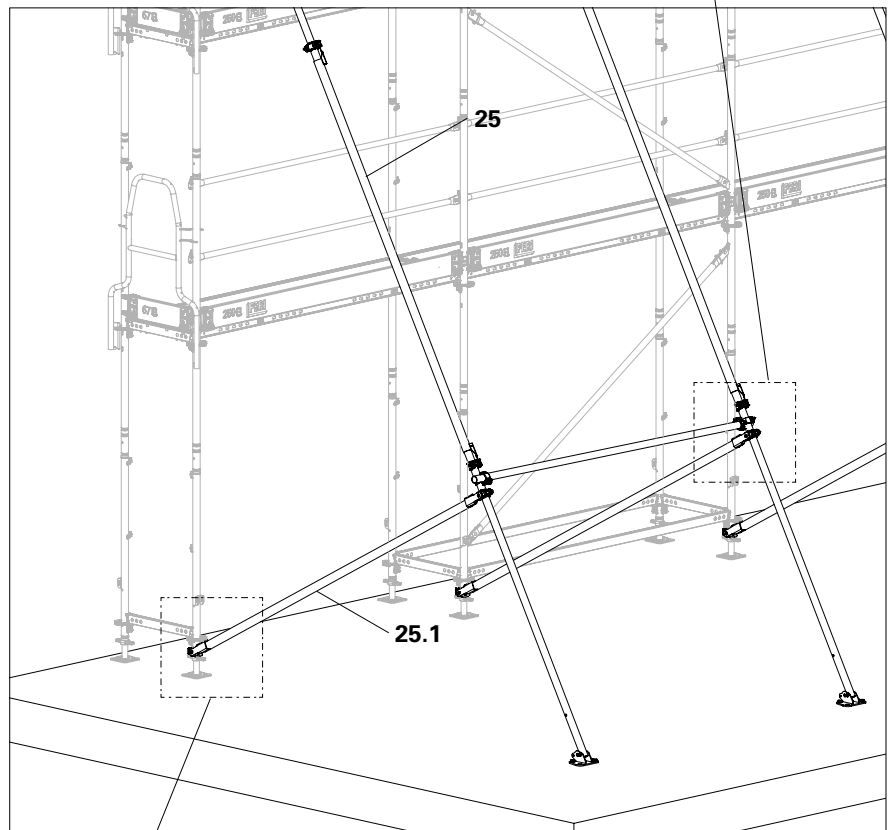

Fig. D7.07

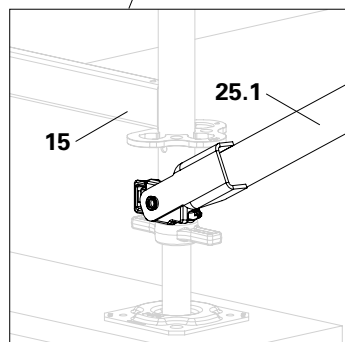

Fig. D7.07b

Push-Pull Prop RS

As an alternative to the multi brace, the scaffold can be supported with Push-Pull Props RS.

Assembly

1. From the first scaffold level, fit a Brace Connector HDR-2 (**101**) onto the outer Easy standard (**23**). Push the coupling as close as possible to the rosette and tighten.
 2. Fit Push-Pull Prop RS 650 (**102**) onto the Brace Connector HDR-2. (Fig. D7.08a)
 3. Spindle out the push-pull prop until the required support angle of $\alpha \leq 60^\circ$ has been reached.
 4. Fix the push-pull prop in the large hole of the base plate with bolts (**103**) and cotter pins (**104**).
 5. Fix Base Plate EWB (**26**) to the substrate. (Fig. D7.08b)
 6. Label the push-pull prop as an obstacle.
- The push-pull prop is now installed. (Fig. D7.08)

Components

23	Easy Standard EVM 200
26	Base Plate EWB
101	Brace Connector HDR-2
102	Push-Pull Prop RS 650
103	Bolt $\varnothing 20 \times 140$
104	Cotter pin 4/1

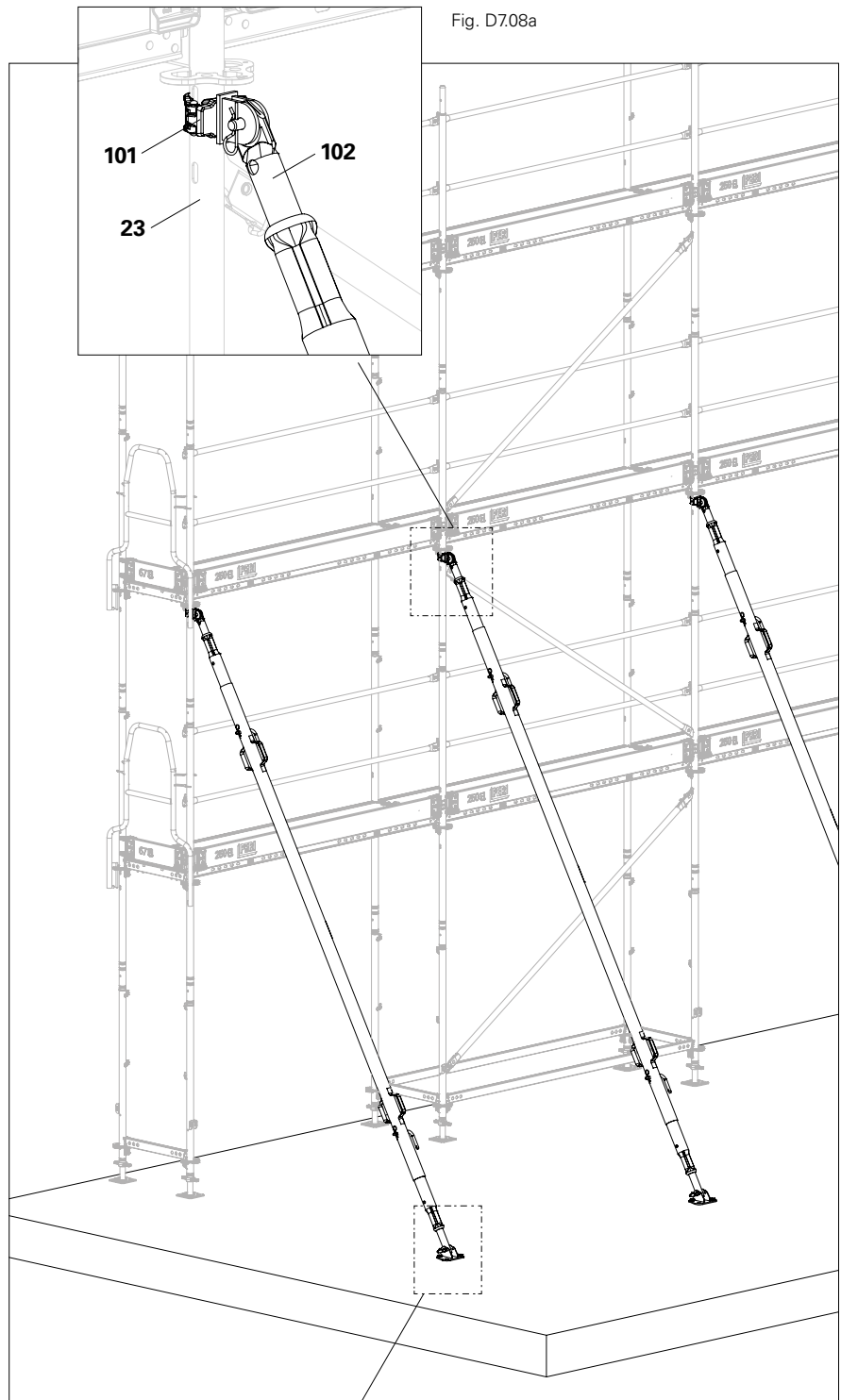

Fig. D7.08a

Fig. D7.08

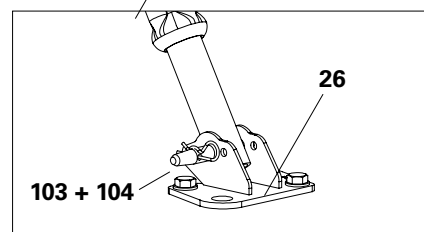

Fig. D7.08b

E1 Load-bearing capacities

Decks



Overview of decks according to lengths, load classes and use as roof edge protection scaffold.

Suitable decks and the corresponding lengths have to be chosen for the respective load class for the standard configuration described in these Instructions for Assembly and Use!

Scaffold deck	Length [m]	Width [m]	Weight [kg]	Load Classes according to EN 12811						Use as roof edge protection scaffold
				1	2	3	4	5	6	
				Uniformly distributed nominal load p [kN/m ²]						
				0.75	1.50	2.00	3.00	4.50	6.00	
Steel Deck EDS	0.67	0.33	5.4	x	x	x	x	x	x	x
	1.00	0.33	7.4	x	x	x	x	x	x	x
	1.50	0.33	10.3	x	x	x	x	x	x	x
	2.00	0.33	13.3	x	x	x	x	x	x	x
	2.50	0.33	16.2	x	x	x	x	x	–	x
	3.00	0.33	19.2	x	x	x	x	–	–	x
Aluminium Deck EDA	0.67	0.67	6.4	x	x	x	x	x	x	x
	1.00	0.67	8.4	x	x	x	x	x	x	x
	1.50	0.67	11.5	x	x	x	x	x	x	x
	2.00	0.67	14.7	x	x	x	x	x	–	x
	2.50	0.67	17.8	x	x	x	x	x	–	x
	3.00	0.67	21.0	x	x	x	–	–	–	x
Combi Deck EDW-2	1.50	0.67	12.1	x	x	x	–	–	–	x
	2.00	0.67	15.1	x	x	x	–	–	–	x
	2.50	0.67	18.5	x	x	x	–	–	–	x
	3.00	0.67	22.3	x	x	x	–	–	–	x
Composite Deck EDC	1.50	0.67	12.5	x	x	x	–	–	–	x
	2.00	0.67	15.6	x	x	x	–	–	–	x
	2.50	0.67	19.2	x	x	x	–	–	–	x
	3.00	0.67	23.2	x	x	x	–	–	–	x
Access Deck EAA	2.50	0.67	24.50	x	x	x	–	–	–	x
	3.00	0.67	27.50	x	x	x	–	–	–	x
Entry Platform EAA	2.00	0.67	17.30	x	x	x	–	–	–	x
Access Deck EAW	2.50	0.67	26.2	x	x	x	–	–	–	x
	3.00	0.67	29.5	x	x	x	–	–	–	x
Entry platform EAW	2.00	0.67	15.80	x	x	x	–	–	–	x
Access Deck EAC	2.50	0.67	24.82	x	x	x	–	–	–	x
	3.00	0.67	28.26	x	x	x	–	–	–	x
Entry Platform EAC	2.00	0.67	16.78	x	x	x	–	–	–	x

x = Use permissible
– = Use not permissible

Load-bearing capacity of the formwork girders

The permissible loads stated in the table apply only when starter tubes are used and load is introduced at the nodes of the diagonal struts.

Load-bearing capacity of the formwork girders				Steel lattice girder ULS		Aluminium Formwork Girder ULA HD	
Type	Spacing of the lateral holders*			Individual load in middle of bay perm. F [kN]	Connecting the chords with bottom chord/top chord [-]	Individual load in middle of bay perm. F [kN]	Connecting the chords with bottom chord/top chord [-]
Height/length [cm]	a1 [cm]	a2 [cm]	a3 [cm]				
Span L = 400 cm							
50/425	200	–	–	15.1	NK/NK	6.3	NK/NK
50/525	200	–	–	15.1	NK/NK	6.3	NK/NK
70/525	200	–	–	20.7	NK/NK	–	–
50/425	100	100	–	30.7	NK/NK	16.3	NK/NK
50/525	100	100	–	30.7	NK/UNK	16.3	NK/NK
70/525	100	100	–	31.1	NK/UNK	–	–
Span L = 500 cm							
50/525	250	–	–	15.1	NK/NK	6.3	NK/NK
50/625	250	–	–	15.1	NK/NK	6.3	NK/NK
50/525	150	100	–	27.2	NK/NK	15.6	NK/NK
50/625	150	100	–	27.4	UNK/NK	15.6	NK/NK
70/525	250	–	–	20.7	NK/NK	–	–
70/625	250	–	–	20.7	NK/NK	–	–
70/525	150	100	–	29.1	UNK/NK	–	–
70/625	150	100	–	29.1	UNK/NK	–	–
Span L = 600 cm							
50/625	300	–	–	8.8	NK/NK	3.5	NK/NK
70/625	300	–	–	12.1	NK/NK	–	–
70/825	300	–	–	12.1	NK/NK	5.0	NK/NK
50/625	150	150	–	17.5	NK/NK	11.5	NK/NK
70/625	150	150	–	23.5	NK/UNK	15.7	NK/UNK
50/625	100	100	100	23.2	NK/NK	13.1	NK/NK
70/625	100	100	100	26.8	NK/UNK	–	–
70/825	100	100	100	26.6	NK/UNK	15.9	NK/NK

* see "Bracing and anchoring" on page 138 ff

NK: Standard coupler, Class B according to DIN EN 74-1

UNK: Standard coupler Class BB with standard coupler Class BB placed underneath (coupler configuration BB/BB) according to DIN EN 74-1

General

- Ties must be installed progressively with the scaffold assembly
- Proof of the load-bearing capacity of the fixing materials between the wall ties and the anchoring base for the tie forces in the tables in Section "F1" or "G1 Tie forces" is required.



Warning

- The structural stability of the scaffold construction is reduced by missing or insufficiently load-bearing ties.
 - Ties do not transfer vertical loads. This could result in the scaffold collapsing.
- ⇒ Adhere to the number and position of the ties shown in Section "F4" or "G4 Tie pattern"!



- In the case of structural arrangements 1a, 1b, 1.2, 2a, 2b, 2.3, in exceptional cases, ties may be fitted at up to 30 cm below the decking transom, but in no more than one tie position. If the pavement gantry profile is smaller, this must be clearly marked!
- If the scaffold ends in what is an unanchored level according to the tie pattern, then it must be anchored to the top anchoring level shown in the tie pattern.

With respect to how the PERI UP Easy scaffolding is used, various equipment variations are shown on the following pages in accordance with the proven standard configurations.

The number and type of ties, the number of braces and horizontal ledgers as well as the maximum spindle extension are shown in the tie patterns.

The following applies for use:

- The ties, vertical braces and horizontal ledgers of the basic variants must always be installed (marked in grey in the variants).
- Additional ties, vertical braces and horizontal ledgers (shown in black) are necessary when these variants are used.
- Contrary to the arrangements depicted in the tie patterns, the external console brackets they show can be mounted on the scaffold on any given level, but on one level only.

Typical tie patterns

Typical tie patterns are shown on the following two pages.

The final tie pattern depends on the factors that exert an influence on the scaffold:

1. Closed/open facades,
2. Cladding,
3. Mounting parts, e.g.:
 - Console brackets,
 - Protection roofs,
 - Pavement gantries,
 - Roof safety scaffolding etc.

Standard variant:

Basic variant 1

For unclad scaffolds in front of open and closed facades **without** internal console bracket.
8 m offset tie pattern.
(Fig. E2.01)

Basic variant 2

For unclad scaffolds in front of open and closed facades **with** internal console bracket.
8 m offset tie pattern.
(Fig. E2.01)

Basic variant 3

For scaffolds with netting in front of closed facades.
8 m offset tie pattern.
(Fig. E2.01)

Basic variant 4

For scaffolds with netting in front of the open facade.
(Fig. E2.02)

Variant 4.4

For scaffolds with tarpaulins in front of closed or open facades.
2 m tie pattern.
(Fig. E2.02a)

Tie pattern 8 m, offset.
Basic variant 1, 2 & 3.

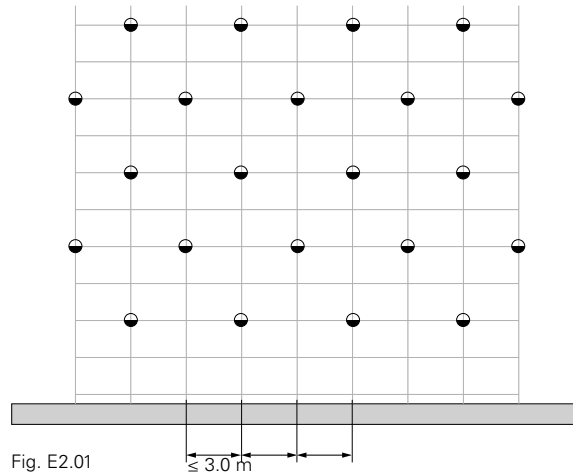

Fig. E2.01

Tie pattern 4 m, offset
Basic variant 4

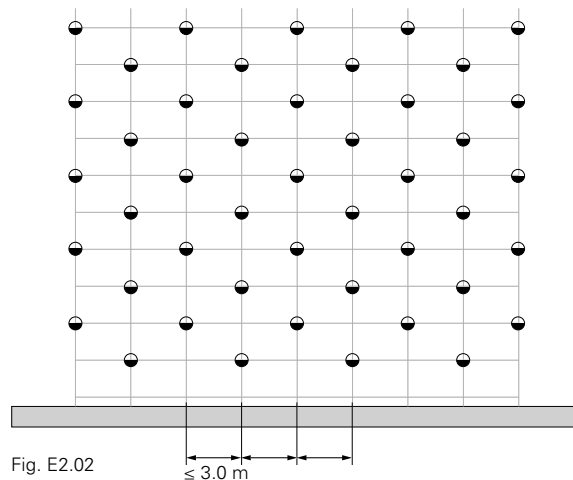

Fig. E2.02

Tie pattern 2 m, offset
Variant 4.4

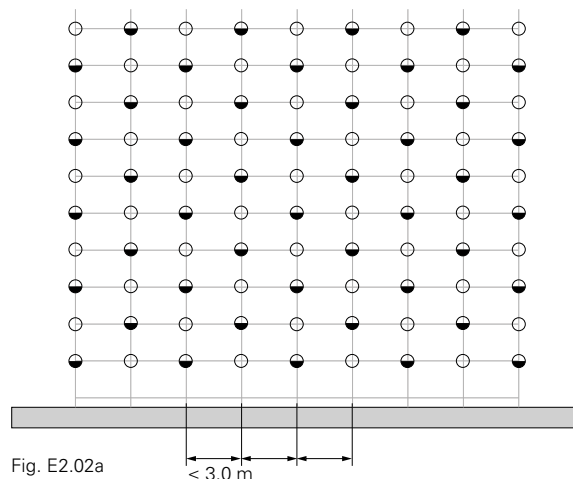
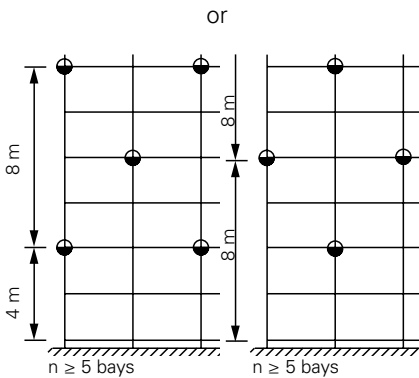

Fig. E2.02a

For tie patterns where $h \leq 24$ m, the following applies:

- Scaffold with a maximum structure height of 24 m plus spindle extension length and standard height on the base standards of 0.18 m.
- In each tie position, at least two wall ties or one triangulated tie are to be fitted in every fifth bay.
- For use in Easy 67 for Load Class LC3
Easy 100 for Load Class LC4
Live load on one scaffold level.
- Scaffold in front of open or closed facade (for open facades up to 60% of the visible area can be openings).
- The tables show the tie forces and the support forces.
- For scaffolds with fewer than 5 bays, the edge standards must be anchored at least every 4 m. For scaffolds with 5 or more bays, the following two variants are permissible:



Wall ties replaced by triangulated ties on all levels:

For basic variants 1, 2 and 4 the tie patterns with wall ties (index a) show the alternatives with triangulated ties (index b).

The alternatives are not shown for basic variant 3. In that arrangement the wall ties can be replaced by triangulated ties (combined with single-standard wall ties) in all tie positions as shown below.

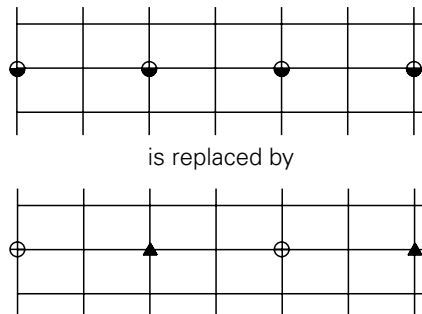

Wall ties replaced by triangulated ties on individual levels:

With all variants, wall ties can be replaced by triangulated ties in individual tie positions as shown below:

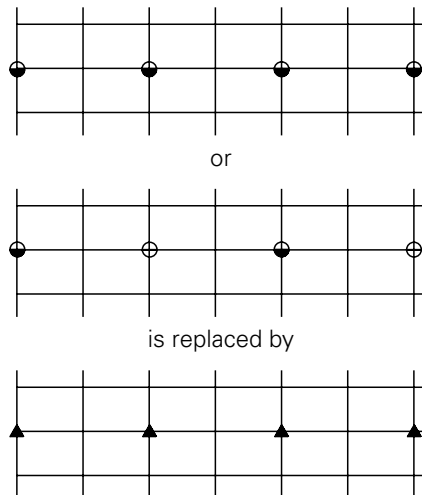

The process is similar for tie positions with external console brackets, with or without protection panels and protection roofs:

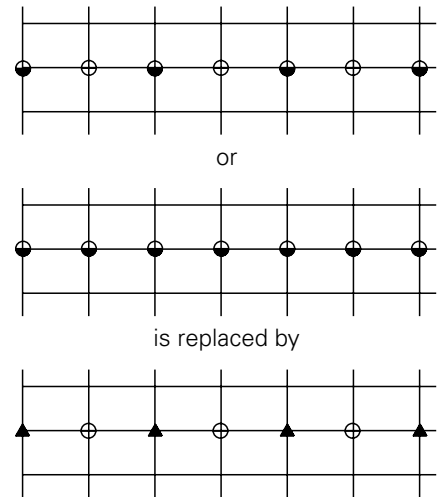

Scaffolds with fewer than 5 bays:

At least three wall ties or two triangulated ties are required in the tie position of protection panels, protection roofs, external or internal console brackets. Each edge standard has to be anchored at vertical spacing of no more than 4 m.

Scaffolds with fewer than 3 bays:

At least two triangulated ties are required in the tie position of protection panels.

Key

- ⊕ Single-standard wall ties
- Wall ties
- ▲ Triangulated ties

Types of anchoring

Single-standard wall tie

For accommodating tensile and compressive forces at right angles to the facade (A_{\perp}).

Attach Wall Tie UWT (**46**) to the Inner Easy Standard EVM (**22**) with Wall Tie Coupler EWC (**45**) or a standard coupler. Use the top slot.

(Fig. E2.03 + E2.04)

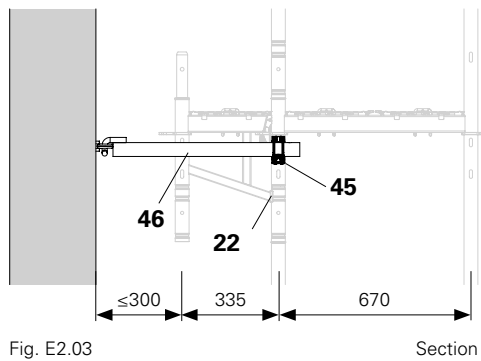

Fig. E2.03

Section

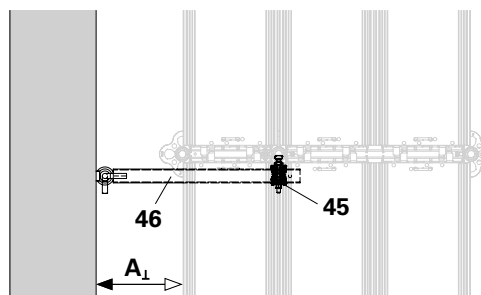
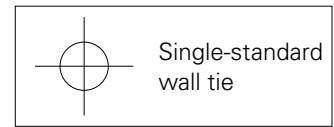

Fig. E2.04

Top view

Wall tie (multi-standard)

For accommodating tensile and compressive forces at right angles and parallel to the facade (A_{\perp} , A_{\parallel}).

Attach Wall Tie UWT (**46**) to the inner (**22a**) and outer Easy standard (**22b**) with one Wall Tie Coupler EWC (**45**) or a standard coupler in each case. Use the top slot in each case.

When using the Wall Tie Coupler EWC (**45**), all Console Brackets ECM 33/67/100 can be anchored at the same time. Not required in the standard configuration.

(Fig. E2.05 + E2.06)

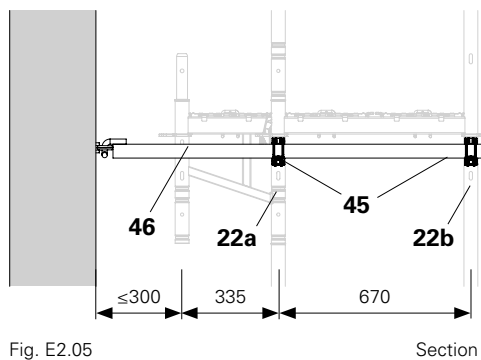

Fig. E2.05

Section

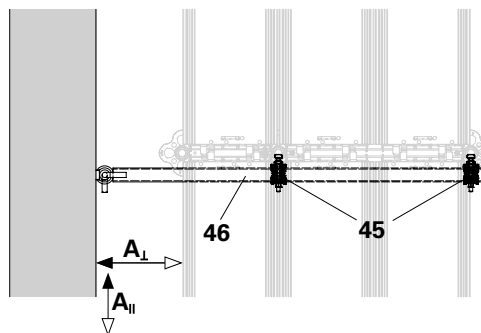
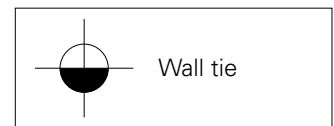

Fig. E2.06

Top view

Components

- | | |
|-----------|-----------------------|
| 23 | Easy Standard EVM 200 |
| 45 | Wall Tie Coupler EWC |
| 46 | Wall Tie UWT |

Triangulated tie

For accommodating tensile and compressive forces at right angles and parallel to the facade (A_I , A_{II}).

Attach two Wall Ties UWT (46) below at approx. 45° to the ledger axis. Attach both wall ties to the inner Easy Standard EVM (22) with standard couplers (48). (Fig. E2.07 + E2.08)

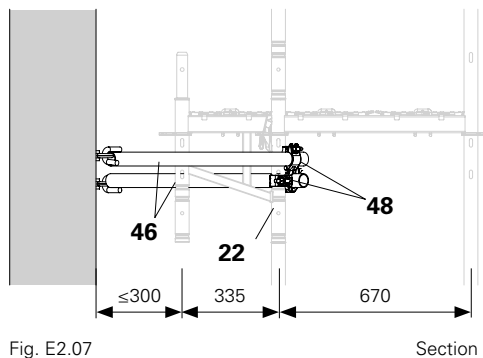

Fig. E2.07

Section



Triangulated tie

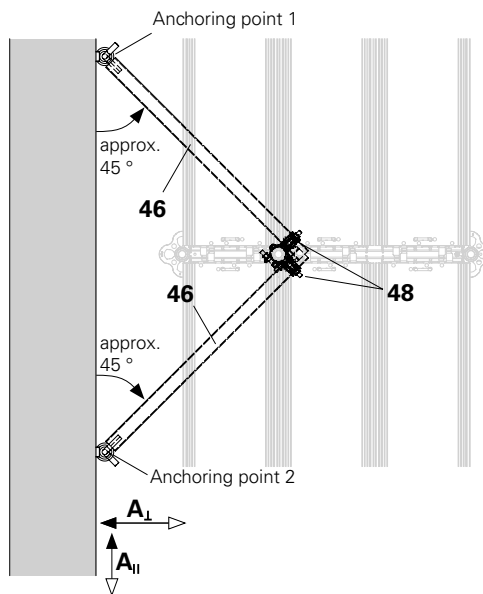

Fig. E2.08

Top view

Pressure-resistant support

Only for accommodating compressive forces at right angles to the facade (A_I).

Attach Wall Tie UWT (46) to the inner Easy Standard EVM (22) with a standard coupler (48). The tube end without a hook is positioned obtusely against the wall. (Fig. E2.09 + E2.10)

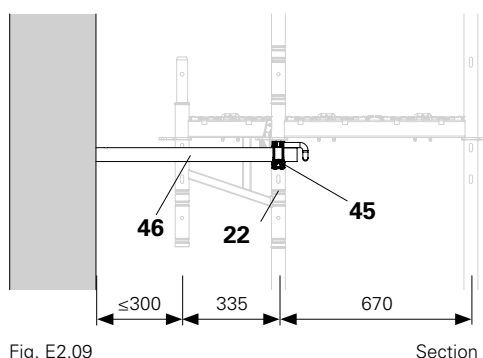
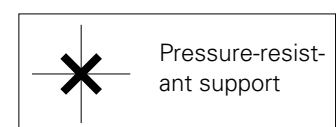

Fig. E2.09

Section



Pressure-resistant support

Components

- 22** Easy Standard EVM 200
- 46** Wall Tie UWT
- 48** Standard coupler

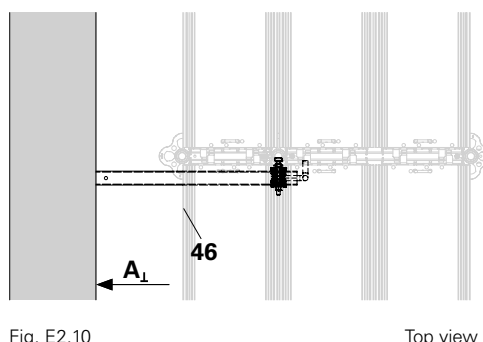

Fig. E2.10

Top view

External scaffold access

For accommodating tensile and compressive forces at right angles and parallel to the facade (A_{\perp} , A_{\parallel}).

Select longer Wall Ties UWT (**46**) for additional anchoring of the external scaffold access at right angles and parallel to the facade.

Connect Wall Tie UWT (**46**) to all three Easy Standards EVM 200 (**22**) with Wall Tie Holder EWC (**45**) or standard couplers.
(Fig. E2.11 + E2.12)

Components

- 22** Easy Standard EVM 200
- 45** Wall Tie Coupler EWC
- 46** Wall Tie UWT

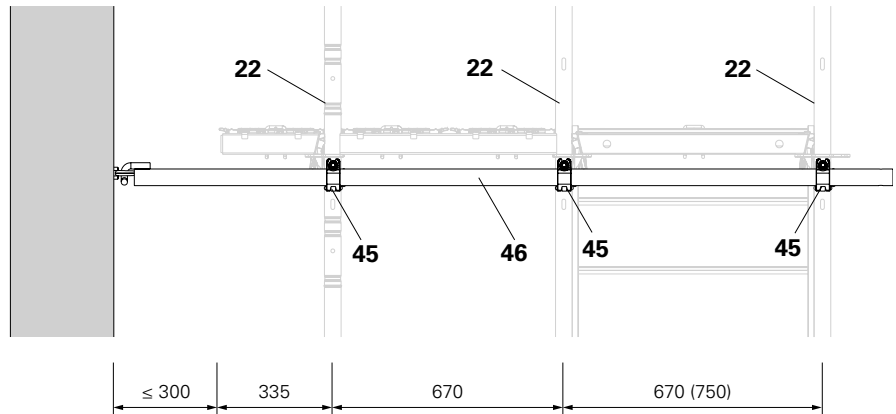
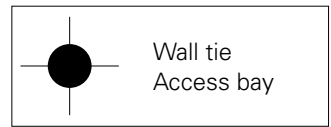

Fig. E2.11

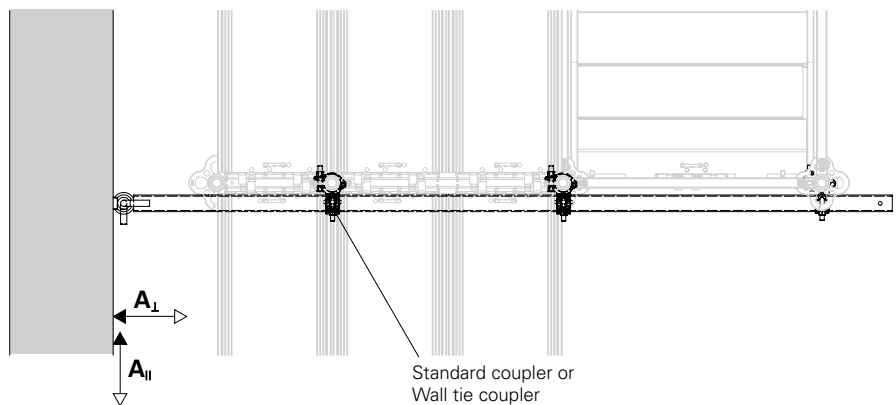

Fig. E2.12

External scaffold access

The external scaffold access bay has to be braced with Horizontal Ledger UH-2 as a longitudinal ledger and Face Brace EBF (20) as a vertical brace and connected to the main scaffold and anchored in accordance with the tie patterns as shown.

The following rules apply:

- The tie patterns shown apply for all equipment variations.
- For connection of the access bay solely to rosettes by means of Horizontal Ledgers UH-2 67, Wall Tie Couplers EWC (45) or standard couplers must always be installed as a supplement to the ties of the main scaffold.
- A tie must be installed in the access bay and this always replaces the tie required in the basic scaffold.

Unclad Tie pattern 4 m

Standard configuration in front of open and closed facades

Netting, closed facade Tie pattern 4 m

Standard configuration in front of closed facade.

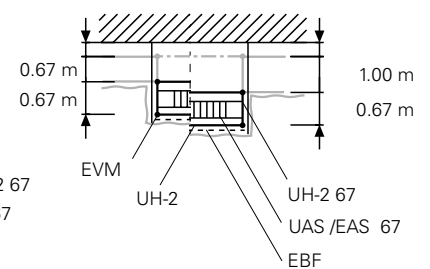
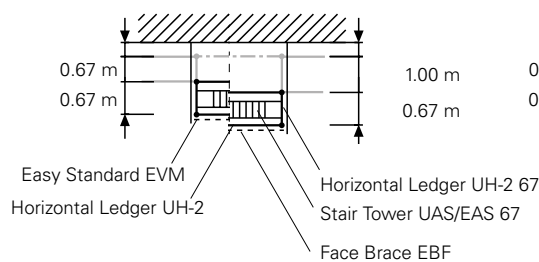
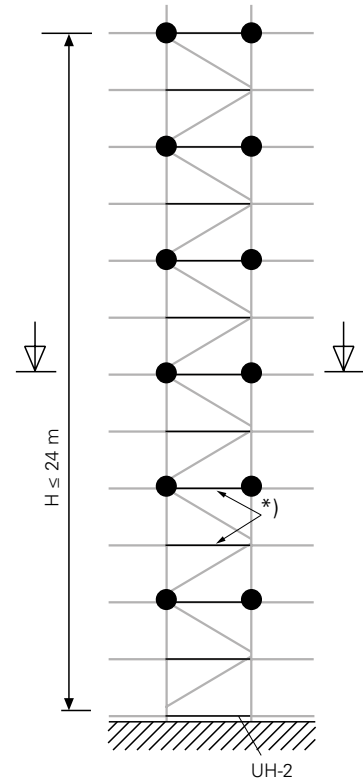
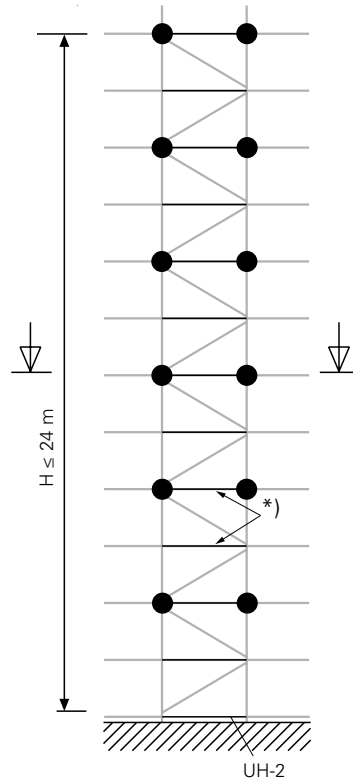

*) Horizontal Ledger UH-2 every 2.00 m

Note: lateral protection components not shown.

Ties, external access:

- Wall ties, access bay

Netting, open facade Tie pattern 4 m, offset.

Standard configuration in front of open facade.

Tarpaulin, open facade Tie pattern 2 m

Standard configuration in front of open facade.

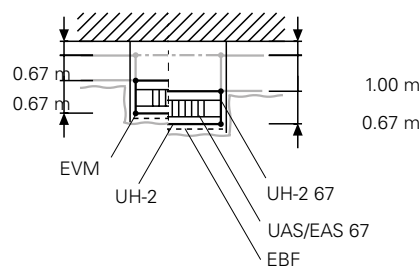
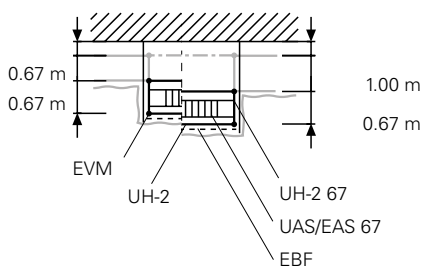
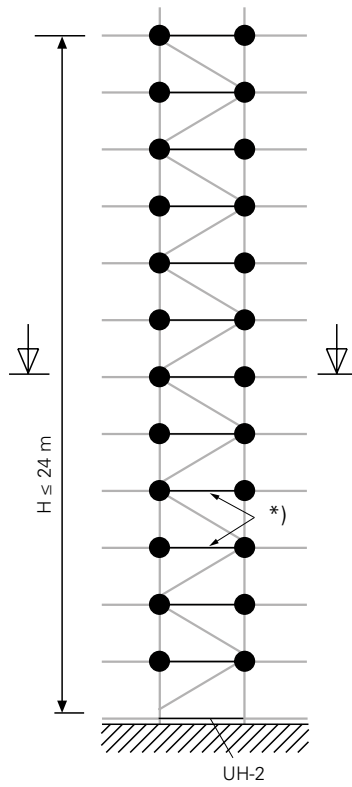
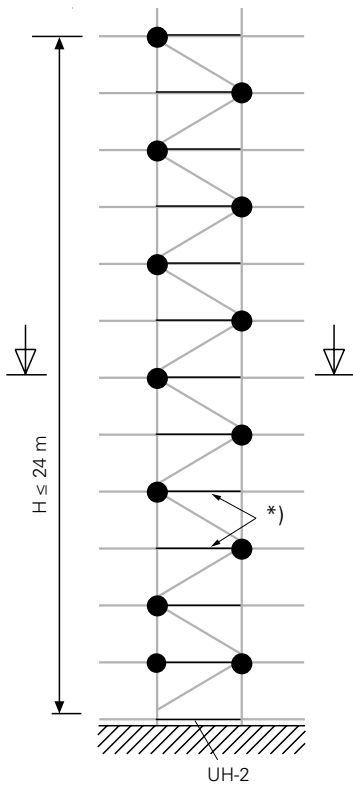

Anchoring with wall ties

PERI UP Easy 67, use in Load Class 3 (2.0 kN/ m ²)									
			Tie forces for (+ = tensile force/- = compressive force) **						
			Standard configuration open facade			Standard configuration closed facade			
Tie pattern	Cladding	Bay length [m]	Full-width wall tie						
			ϕ A _⊥ [kN]	ϕ A _∥ [kN]	ϕ A _⊥ [kN]	ϕ A _∥ [kN]	ϕ A _⊥ [kN]	ϕ A _∥ [kN]	
8.0 m offset	without	2.00	+/-2.8		2.2*		+/-0.9		2.2*
		2.50	+/-3.3		2.2*		+/-1.1		2.2*
		3.00	+/-3.8		2.2*		+/-1.3		2.2*
	with netting	2.00	not possible				+/-2.3		2.6
		2.50	not possible				+/-2.9		2.6
		3.00	not possible				+/-3.4		2.6
4.0 m	without	2.00	+/-1.4		1.1*		+/-0.5		2.2*
		2.50	+/-1.7		1.1*		+/-0.6		2.2*
		3.00	+/-1.9		1.1*		+/-0.6		2.2*
	with netting	2.00	not possible				+/-1.1		2.6
		2.50	not possible				+/-1.4		2.6
		3.00	not possible				+/-1.7		2.6
4.0 m offset	with netting	2.00	+/-3.0		2.0		+/-1.0		2.0
		2.50	+/-3.7		2.0		+/-1.2		2.0
		3.00	+/-4.5		2.0		+/-1.5		2.0
	with tarpaulin	2.00	not possible				not possible		
		2.50	not possible				not possible		
		3.00	not possible				not possible		
2.0 m	with tarpaulin	2.00	-4.4	+4.0	1.7	-4.4	+2.7	1.7	
		2.50	-5.5	+4.9	1.7	-5.5	+3.4	1.7	
		3.00	-6.6	+5.9	1.7	-6.6	+4.1	1.7	

open facade vs. closed facade depends on ratio of gross visible area of the facade A_g to net visible area of the facade with openings deducted A_n :
 $A_n/A_g = 1.0$: closed facade
 $A_n/A_g = 0.4 \leq x < 1.0$: open facade

** For protection panels, use whichever of the "open" and "closed" facade standard configurations is the worse.

* If there are only two continuous scaffold ties per five bays (variant 1), multiply the table value by 1.5.

Anchoring with triangulated ties or single-standard wall ties

PERI UP Easy 67, use in Load Class 3 (2.0 kN/ m ²)										
			Tie forces for (+ = tensile force/- = compressive force) *							
			Standard configuration open facade			Standard configuration closed facade				
Tie pattern	Cladding	Bay length [m]	Single-standard wall tie	Triangulated tie (per anchoring point)		Single-standard wall tie	Triangulated tie (per anchoring point)			
			ϕ A ₁ [kN]	+ A ₁ [kN]	+ A ₁ [kN]	ϕ A ₁ [kN]	+ A ₁ [kN]	+ A ₁ [kN]		
8.0 m offset	without	2.00	+/-2.6	+/-2.9	2.9	+/-0.9	+/-2.9	2.9		
		2.50	+/-3.1	+/-2.9	2.9	+/-1.0	+/-2.9	2.9		
		3.00	+/-3.5	+/-2.9	2.9	+/-1.2	+/-2.9	2.9		
	with netting	2.00	not possible			+/-1.8	+/-3.8	3.8		
		2.50	not possible			+/-2.2	+/-3.8	3.8		
		3.00	not possible			+/-2.7	+/-3.8	3.8		
4.0 m	without	2.00	+/-1.3	+/-2.9	2.9	+/-0.4	+/-2.9	2.9		
		2.50	+/-1.5	+/-2.9	2.9	+/-0.5	+/-2.9	2.9		
		3.00	+/-1.8	+/-2.9	2.9	+/-0.6	+/-2.9	2.9		
	with netting	2.00	not possible			+/-0.9	+/-3.8	3.8		
		2.50	not possible			+/-1.1	+/-3.8	3.8		
		3.00	not possible			+/-1.3	+/-3.8	3.8		
4.0 m offset	with netting	2.00	+/-1.9	+/-2.0	2.0	+/-0.6	+/-2.0	2.0		
		2.50	+/-2.3	+/-2.0	2.0	+/-0.8	+/-2.0	2.0		
		3.00	+/-2.8	+/-2.0	2.0	+/-0.9	+/-2.0	2.0		
	with tarpaulin	2.00	not possible			not possible				
		2.50	not possible			not possible				
		3.00	not possible			not possible				
2.0 m	with tarpaulin	2.00	-4.2	+3.8	+/-3.3	3.3	-4.2	+2.6	+/-3.3	3.3
		2.50	-5.3	+4.8	+/-3.3	3.3	-5.3	+3.3	+/-3.3	3.3
		3.00	-6.4	+5.7	+/-3.3	3.3	-6.4	+3.9	+/-3.3	3.3

open facade vs. closed facade depends on ratio of gross visible area of the facade A_g to net visible area of the facade with openings deducted A_n:
 A_n/A_g = 1.0 : closed facade
 A_n/A_g = 0.4 ≤ x < 1.0 : open facade

* For protection panels, use whichever of the "open" and "closed" facade standard configurations is the worse.

Basic scaffold – Load Class 3

PERI UP Easy 67, use in Load Class 3 (2.0 kN/ m ²)						
	Equipment	Bay length [m]	Structure height			
			24 m	16 m	8 m	
	Inner leg		F_i [kN]	F_i [kN]	F_i [kN]	
	without internal console brackets	2.0	7.8	6.9	6.0	
		2.5	9.2	8.2	7.2	
		3.0	10.6	9.5	8.4	
	with Internal Console Brackets UCS 33	2.0	9.8	8.2	6.6	
		2.5	11.7	9.9	8.0	
		3.0	13.6	11.5	9.5	
	Outer leg		F_a [kN]	F_a [kN]	F_a [kN]	
	without external console bracket	2.0	8.6	7.2	5.8	
		2.5	10.3	8.6	7.0	
		3.0	12.0	10.1	8.2	
				additional to F_a [kN]		
	with external console bracket ECM 33	2.0	1.5			
		2.5	1.9			
		3.0	2.3			
	with external console bracket ECM 67	2.0	3.0			
		2.5	3.8			
		3.0	4.5			
	Protection panel (in addition to console bracket or frame)	2.0	0.2			
		2.5	0.2			
		3.0	0.3			
	Protection roof on Console Bracket ECM 67 (incl. Console Bracket ECM 67)	2.0	0.7			
2.5		0.8				
3.0		0.9				
Protection roof on console bracket ECM 100 (incl. Console bracket ECM 100)	2.0	0.8				
	2.5	1.0				
	3.0	1.2				

Pavement gantries/bridgings

PERI UP Easy 67, use in Load Class 3 (2.0 kN/ m²)

Pavement gantry

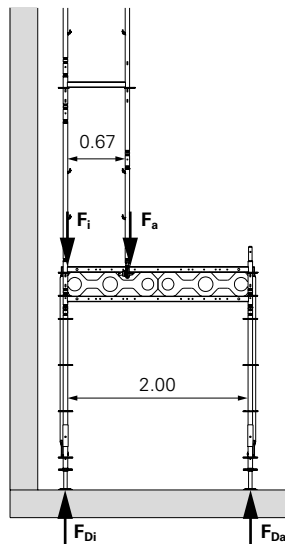

F_{Da}
[kN]

F_{Di}
[kN]

$0.45 \times F_a$

$F_i + 0.6 \times F_a$

Bridgings

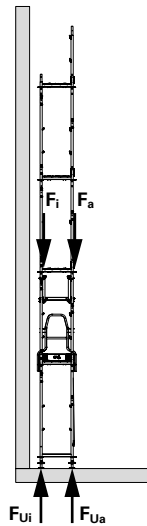
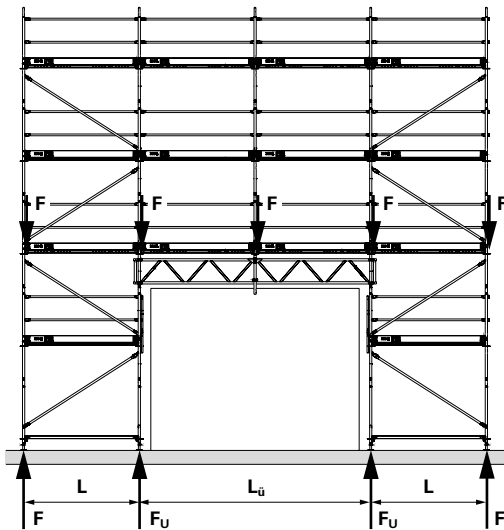

Bay length L
[m]

F_{Ua}
[kN]

F_{Ui}
[kN]

L_ü = 4.0 m

2.50

$1.35 \times F_a$

$1.35 \times F_i$

3.00

$1.25 \times F_a$

$1.25 \times F_i$

L_ü = 5.0 m

2.50

$1.50 \times F_a$

$1.50 \times F_i$

3.00

$1.40 \times F_a$

$1.40 \times F_i$

L_ü = 6.0 m

2.50

$1.70 \times F_a$

$1.70 \times F_i$

3.00

$1.50 \times F_a$

$1.50 \times F_i$

Select F_a and F_i for appropriate bay length L.

Overview of requirements for formwork girders Load Class 3

PERI UP Easy 67: LC3 – 2.0 kN/m ² bridging overview																					
LC3 – 2.0 kN/m ²		5 m					6 m														
		Steel ULS		Aluminium ULA			Steel ULS			Aluminium ULA											
Formwork girder	Type	50/625	70/625	100	150	250	300	50/625	70/625	100	150	250	300	50/625	70/625	100	150	250	300		
Spacing of the lateral holders a [cm]		250	100	250	100	250	100	250	100	250	100	250	100	250	100	250	100	250	100		
permissible Individual load in middle of bay [kN]		15.1	27.2	15.1	27.4	20.7	29.1	15.6	6.30	15.6	6.30	15.6	6.30	11.5	13.1	5.0	15.7	15.9	5.00		
resulting individual load F to be carried by the lattice girder, depending on bay length and equipment		Required number of formwork girders, inside and outside																			
Equipment	Individual load F [kN] for bay width	2.50 m	3.00 m																		
		8.5	9.8	1x	1x	1x	1x	1x	1x	1x	1x	1x	1x	1x	1x	1x	1x	1x	1x	1x	
Inner leg without internal console brackets	12.5	14.4	1x	1x	1x	1x	1x	1x	1x	1x	1x	1x	1x	1x	1x	1x	1x	1x	1x	1x	
Inner standard with internal console brackets (Support UCS 33)																					
Outer leg without attachment parts	9.3	10.7	1x	1x	1x	1x	1x	1x	1x	1x	1x	1x	1x	1x	1x	1x	1x	1x	1x	1x	
Outer leg with attachment parts In addition to individual load F	With protection panel on outer leg	0.3	0.3	1x	1x	1x	1x	1x	1x	1x	1x	1x	1x	1x	1x	1x	1x	1x	1x	1x	
	And protection roof on console bracket	ECM 67	0.8	1.0	1x	1x	1x	1x	1x	1x	1x	1x	1x	1x	1x	1x	1x	1x	1x	1x	1x
		ECM 100	1.0	1.2	1x	1x	1x	1x	1x	1x	1x	1x	1x	1x	1x	1x	1x	1x	1x	1x	1x
	And with one console bracket; only one on any level, possible on the topmost level with protection panel up to a height of 2.0 m	ECM 33	1.9	2.3	1x	1x	1x	1x	1x	1x	1x	1x	1x	1x	1x	1x	1x	1x	1x	1x	1x
		ECM 67	3.8	4.5	2x	1x	1x	1x	1x	1x	1x	1x	1x	1x	1x	1x	1x	1x	1x	1x	1x
ECM 100		5.6	6.7	2x	1x	1x	1x	1x	1x	1x	1x	1x	1x	1x	1x	1x	1x	1x	1x	1x	

– not permissible within the standard configuration
 1x: permissible, with 1 x 2 formwork girders
 2x: permissible, with 2 x 2 formwork girders

F4 Tie pattern

Key

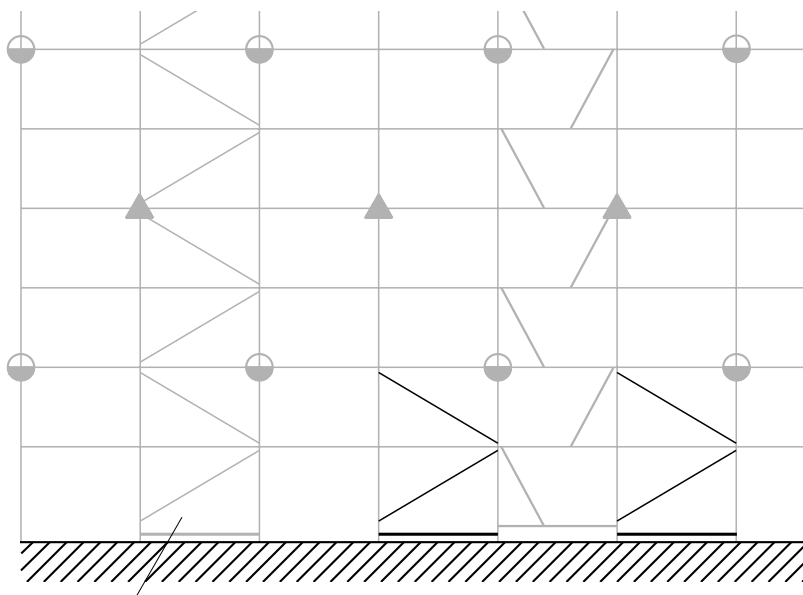
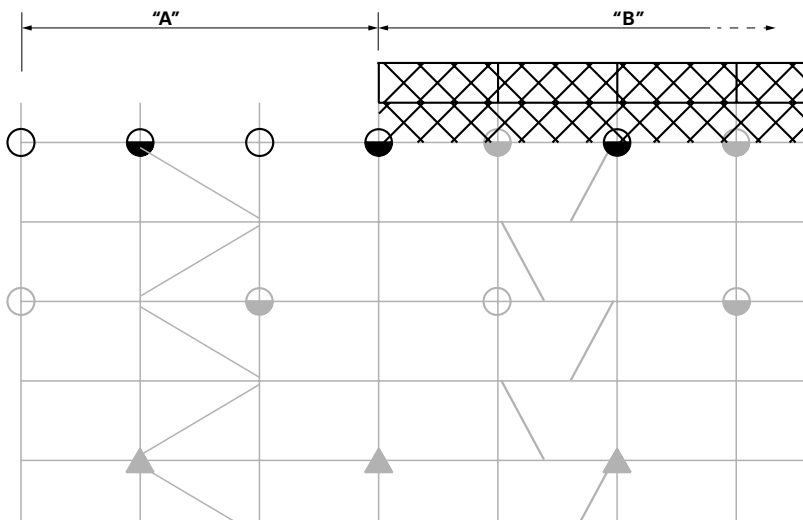

Braced bay

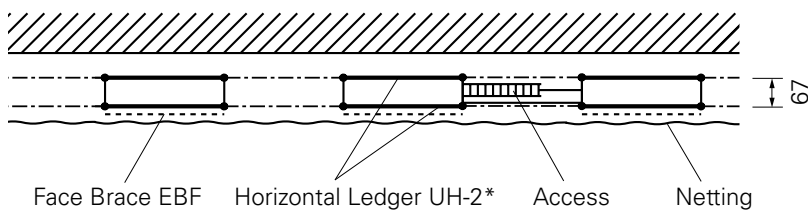

*Unless stated otherwise, horizontal ledgers are only required at the base level



All tie patterns illustrated are shown as a continuous scaffold with a left-hand edge post. There is no separation between the areas "A" and "B". At the right-hand edge of the illustration, the scaffold continues to run as intended.

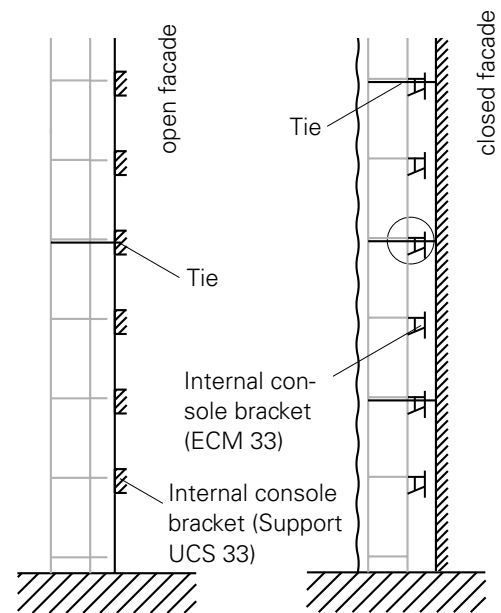
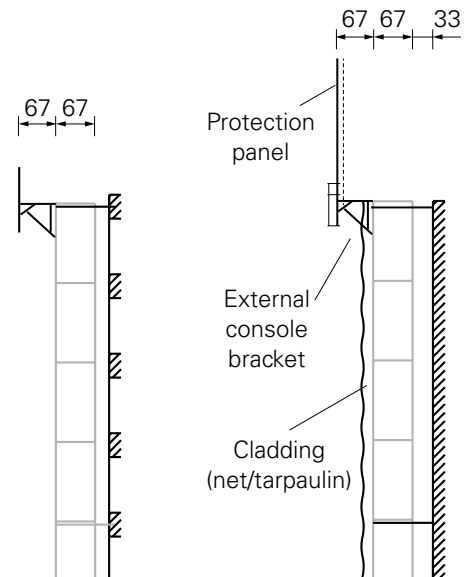

Tie types

- ⊕ Single-standard wall tie
- Wall tie (multi-standard)
- ▲ Triangulated tie

Ties and bracing shown in grey are already included in the respective basic variant.

Modified or additional ties and bracing are shown in black.

Meanings of the pictograms

- 67**
LC 3 PERI UP Easy 67
Load Class 3 (2.0 kN/m²)
- Maximum spindle extension
height h (incl. plate and nut)
- without console brackets

Extension console brackets

- 33**
67 External console
bracket ECM 33 or
ECM 67
- Internal console
brackets UCS 33 or
ECM 33

Protection roof

- 67** on Console Bracket ECM 67
- 100** on Console Bracket ECM 100

Protection panel

- on Easy standard
- 33** on External Console Bracket
ECM 33
- 67** on External Console Bracket
ECM 67

Pavement gantry

- 67**
Pavement gantry

attachment parts not shown

Protection roof

- 67** on Console Bracket ECM 67
- 100** on Console Bracket
ECM 100

Bridging

- 6 m**
6 m, with formwork girders

Scaffold with netting

- Netting**
in front of closed facade
- Netting**
in front of open facade
(with <60% opening)

Scaffold with tarpaulin

- Tarpaulin**
in front of closed facade
- Tarpaulin**
in front of open facade
(with <60% opening)

Equipment variations:
Possible with additional local ties,
cf. equipment variation tables.

Graphical tie pattern Standard variant ≤ 24 m

Basic variant 1a/LC3

Standard configuration:
unclad scaffold in front of open or closed facade.

			67 LC 3
--	--	--	-------------------



OR



8 m offset tie pattern

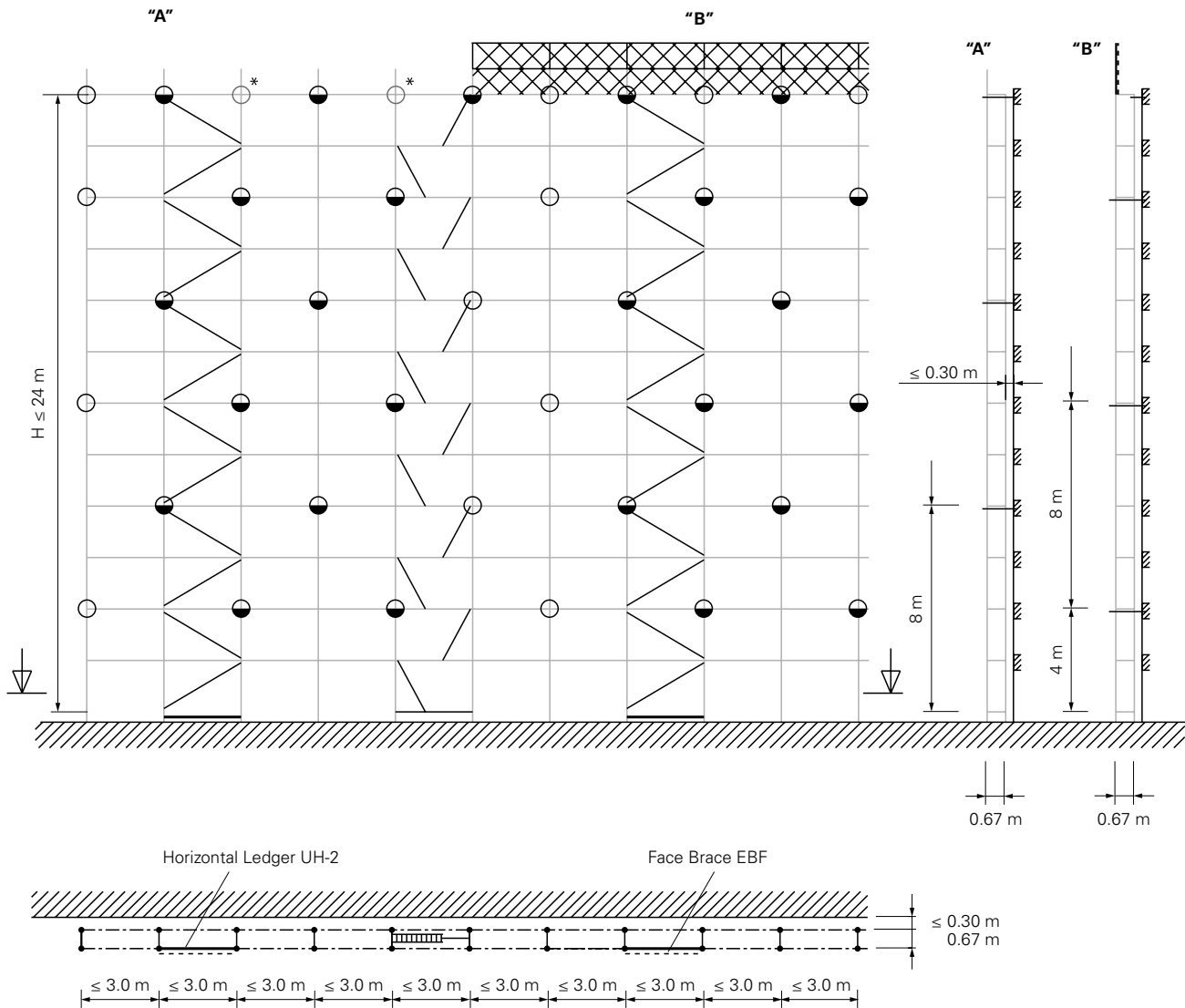

* Only required with partially open facade.
Note: lateral protection components not shown.

- Single-standard wall tie
- Wall tie

Standard variant ≤ 24 m

Basic variant 1a/LC3

Protection roof design

Take the following points into account in addition to the specified assembly guidelines for basic variant 1a.

Tie pattern

- Anchor the protection roof position in each frame column with a wall tie.

Bracing

- No additional bracing required.

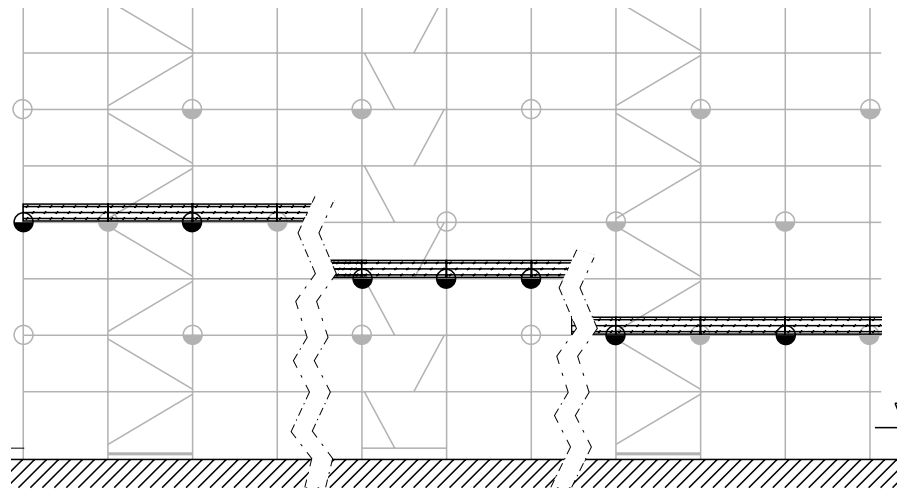

Note: lateral protection components not shown.

- ⊕ Single-standard wall tie
- Wall tie

F4 Tie pattern

Standard variant ≤ 24 m

Basic variant 1b/LC3

Standard configuration:
unclad scaffold in front of open or closed facade.

			67 LC 3
--	--	--	-------------------



or



8 m offset tie pattern

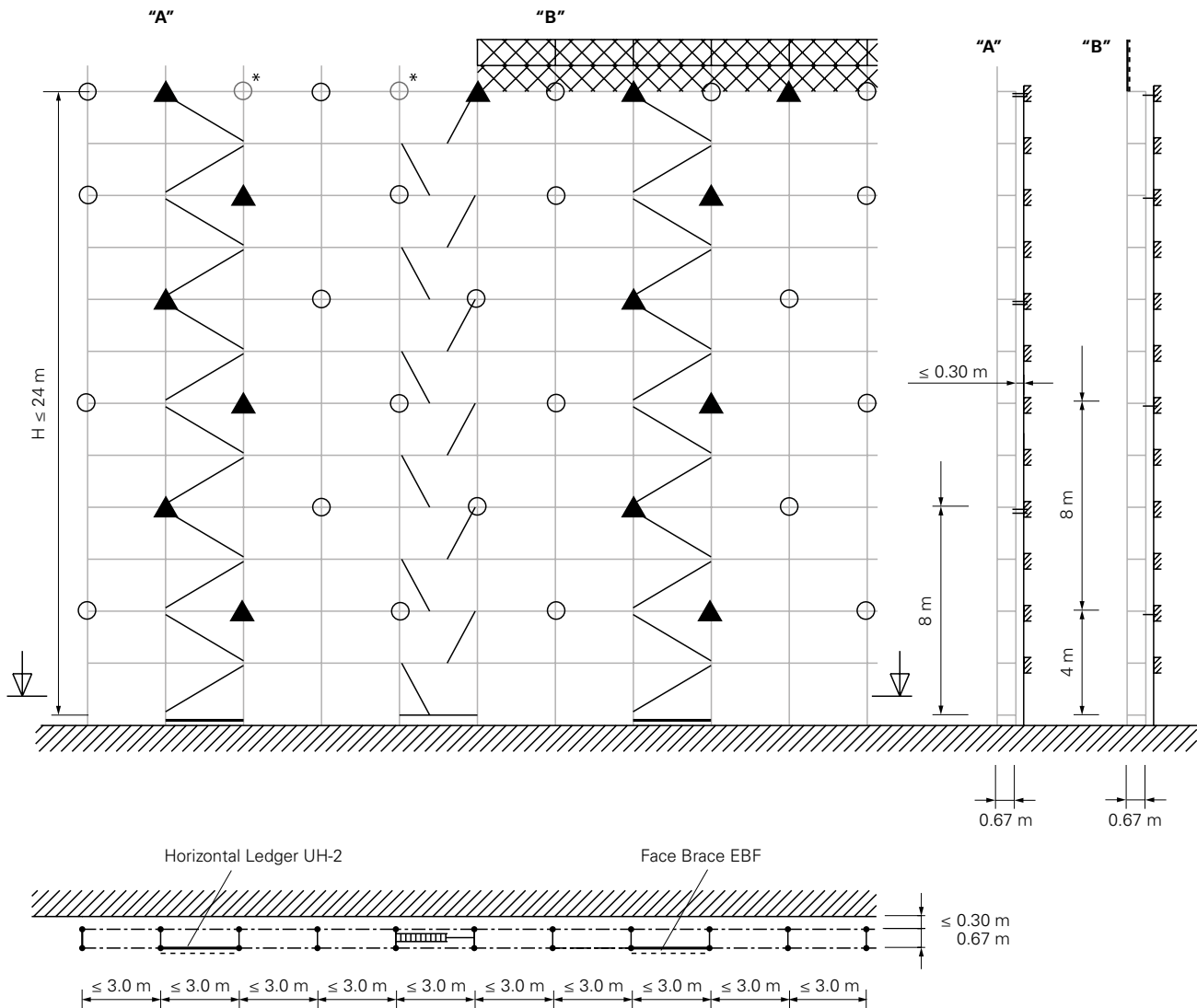

* Only required with partially open facade.
Note: lateral protection components not shown.

- ⊕ Single-standard wall tie
- ▲ Triangulated tie

Standard variant ≤ 24 m

Basic variant 1b/LC3

Protection roof design

Take the following points into account in addition to the specified assembly guidelines for basic variant 1b.

Tie pattern

- Anchor the protection roof position in every second frame column with triangulated ties.
- Anchor all other frame columns with single-standard wall ties

Bracing

- No additional bracing required.

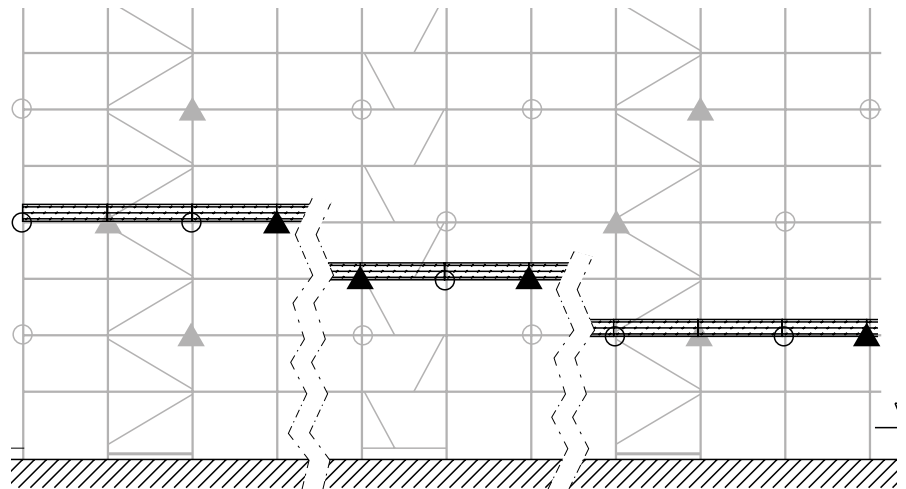

Easy 67

Note: lateral protection components not shown.

- ⊕ Single-standard wall tie
- ▲ Triangulated tie

F4 Tie pattern

Standard variant ≤ 24 m

Variante 1.1/LC3

Standard configuration:
unclad scaffold in front of open or closed facade.

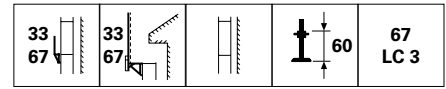

OR



8 m offset tie pattern

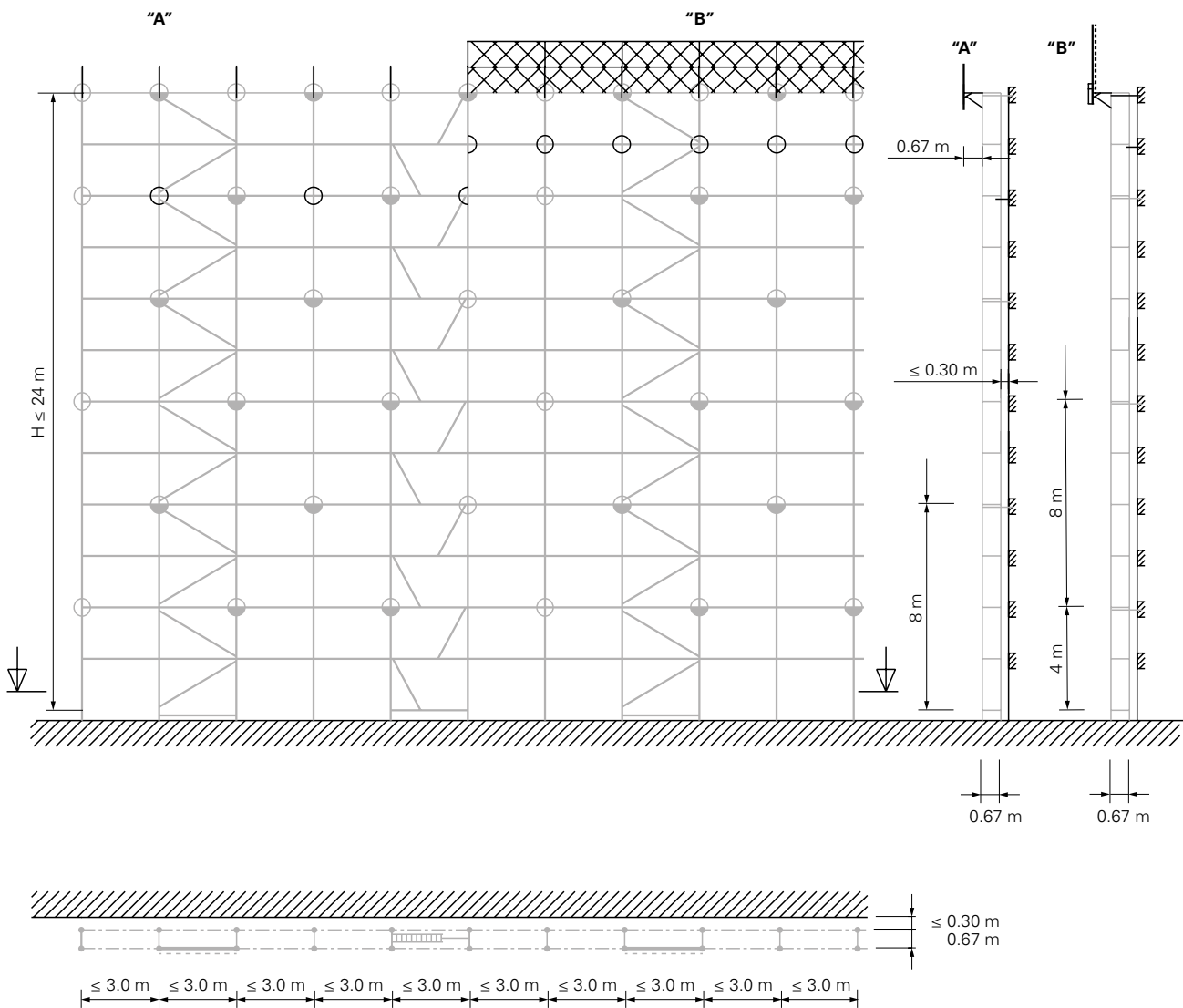

Note: lateral protection components not shown.

- ⊕ Single-standard wall tie
- ⊙ Wall tie

Standard variant ≤ 24 m

Variant 1.1/LC3

Protection roof design

Take the following points into account in addition to the specified assembly guidelines for variant 1.1.

Tie pattern

- Anchor the protection roof position in each frame column with a wall tie.
- for protection roof in scaffold level 2, establish the tie position above the protection roof with at least one single-standard wall tie.

Bracing

- No additional bracing required.

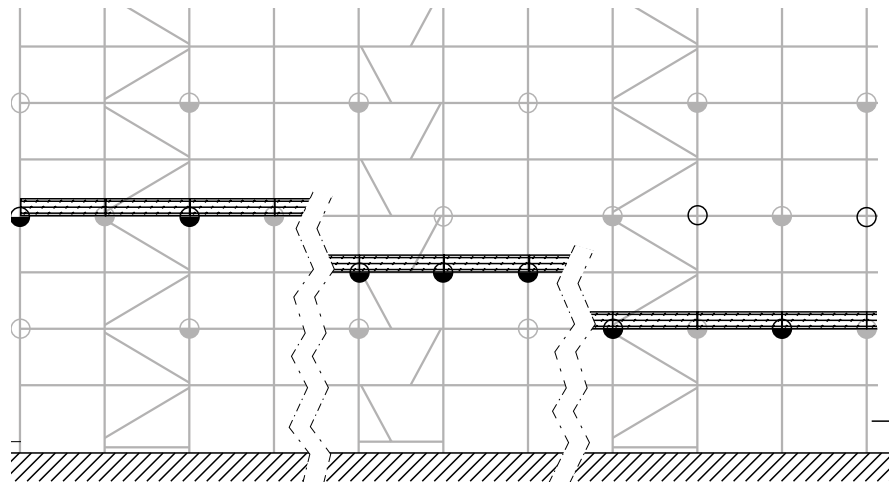

Note: lateral protection components not shown.

- ⊕ Single-standard wall tie
- Wall tie

F4 Tie pattern

Standard variant ≤ 24 m

Variante 1.2/LC3 – bridging 6 m (5 m)

Standard configuration:
unclad scaffold in front of open or closed facade.

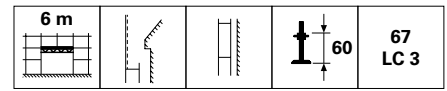

OR



8 m offset tie pattern

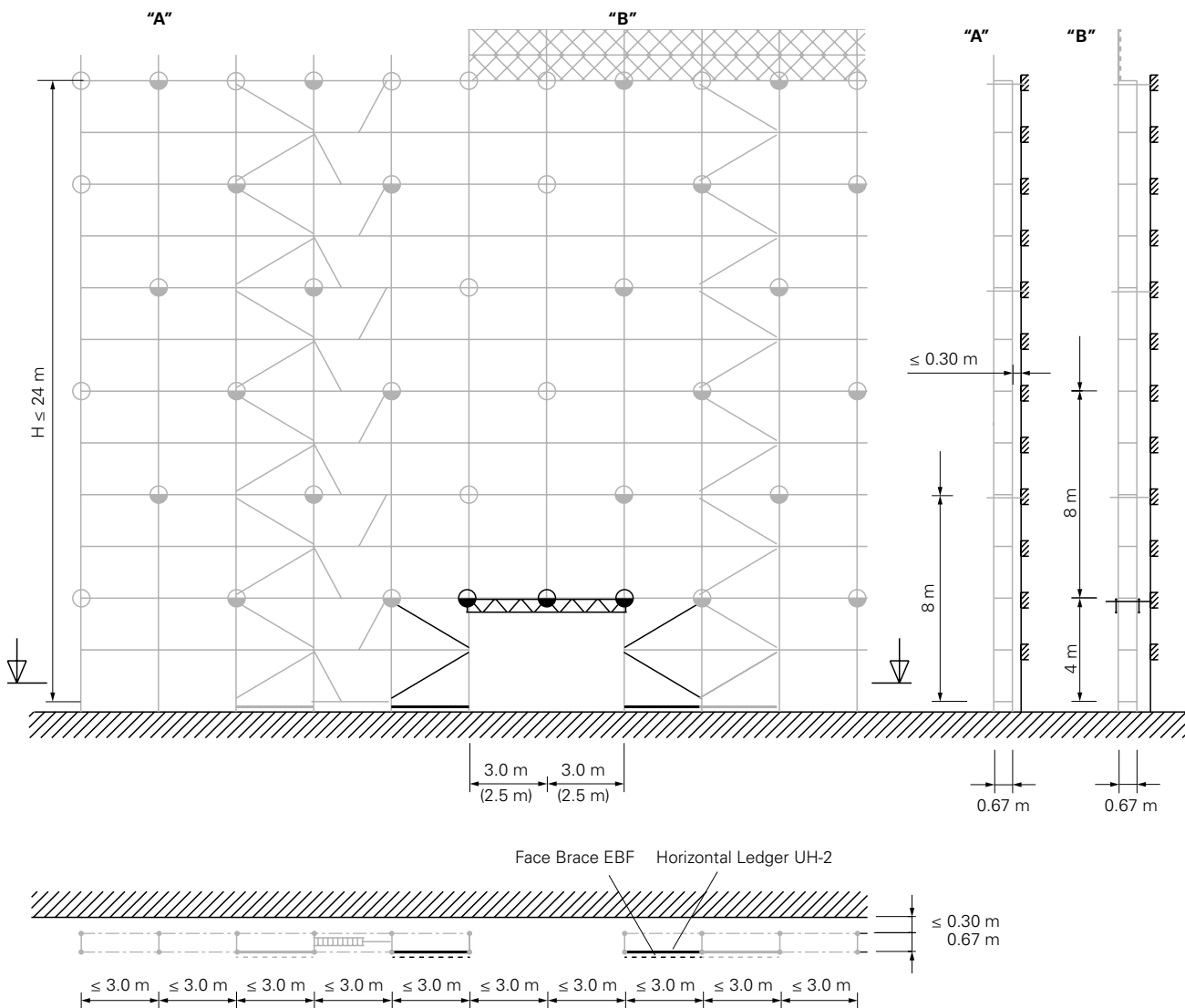

Note: lateral protection components not shown.

- ⊕ Single-standard wall tie
- ⊙ Wall tie

Standard variant ≤ 24 m

Variant 1.2/LC3

Protection roof execution

Take the following points into account in addition to the specified assembly guidelines for variant 1.2.

Tie pattern

- Anchor the protection roof position in each frame column with a wall tie.
- for protection roof in scaffold level 2, establish the tie position above the protection roof with at least one single-standard wall tie.

Bracing

- No additional bracing required.

Note

On the bridging girder, the Console Bracket ECM 67 is the only console bracket that is structurally viable in scaffold level 2.

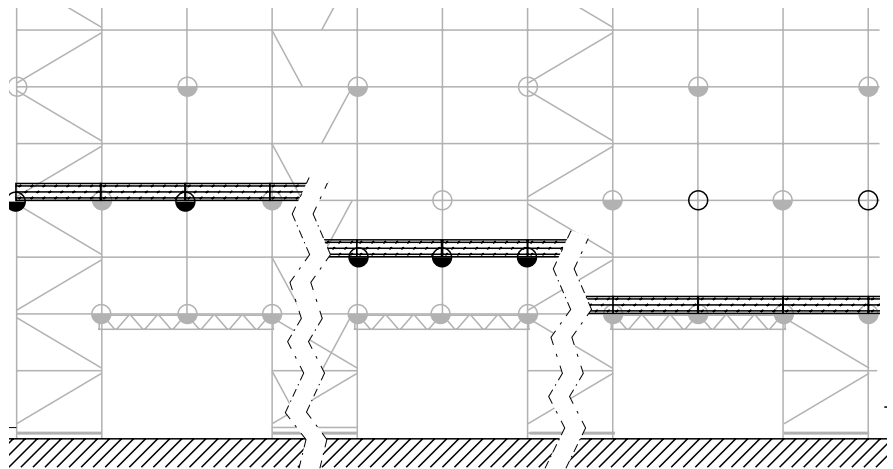

Note: lateral protection components not shown.

- ⊕ Single-standard wall tie
- Wall tie

F4 Tie pattern

Standard variant ≤ 24 m

Variant 1.3/LC3 – bridging 6 m (5 m)

Standard configuration:
unclad scaffold in front of open or closed facade.

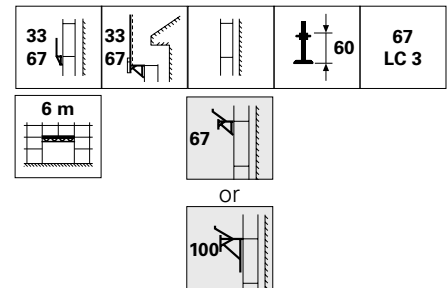

8 m offset tie pattern

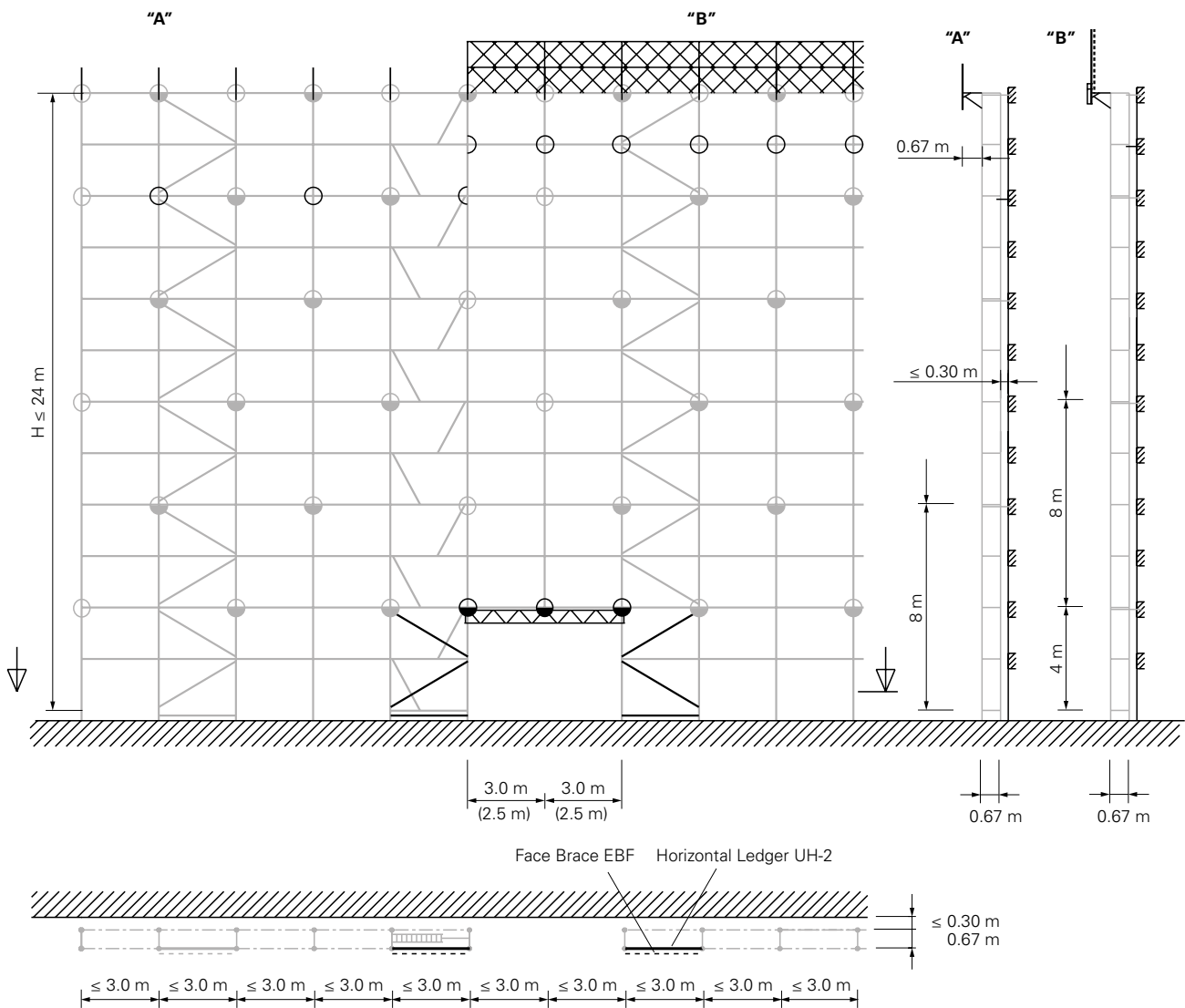

Note: lateral protection components not shown.

- ⊕ Single-standard wall tie
- ⊙ Wall tie

Standard variant ≤ 24 m

Variant 1.3/LC3

Protection roof execution

Take the following points into account in addition to the specified assembly guidelines for variant 1.3.

Tie pattern

- Anchor the protection roof position in each frame column with a wall tie.
- for protection roof in scaffold level 2, establish the tie position above the protection roof with at least one single-standard wall tie.
- for protection roof in scaffold level 2, anchor the frame columns at the bridging using single-standard wall ties.

Bracing

- No additional bracing required.

Note

On the bridging girder, the Console Bracket ECM 67 is the only console bracket that is structurally viable in scaffold level 2.

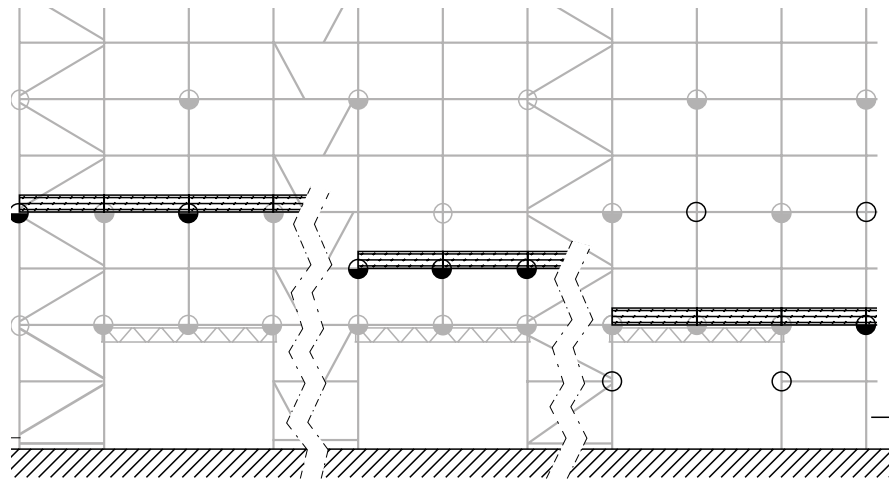

Note: lateral protection components not shown.

- ⊕ Single-standard wall tie
- Wall tie

F4 Tie pattern

Standard variant ≤ 24 m

Variant 1.4/LC3, pavement gantry

Standard configuration:
unclad scaffold in front of open or closed facade.

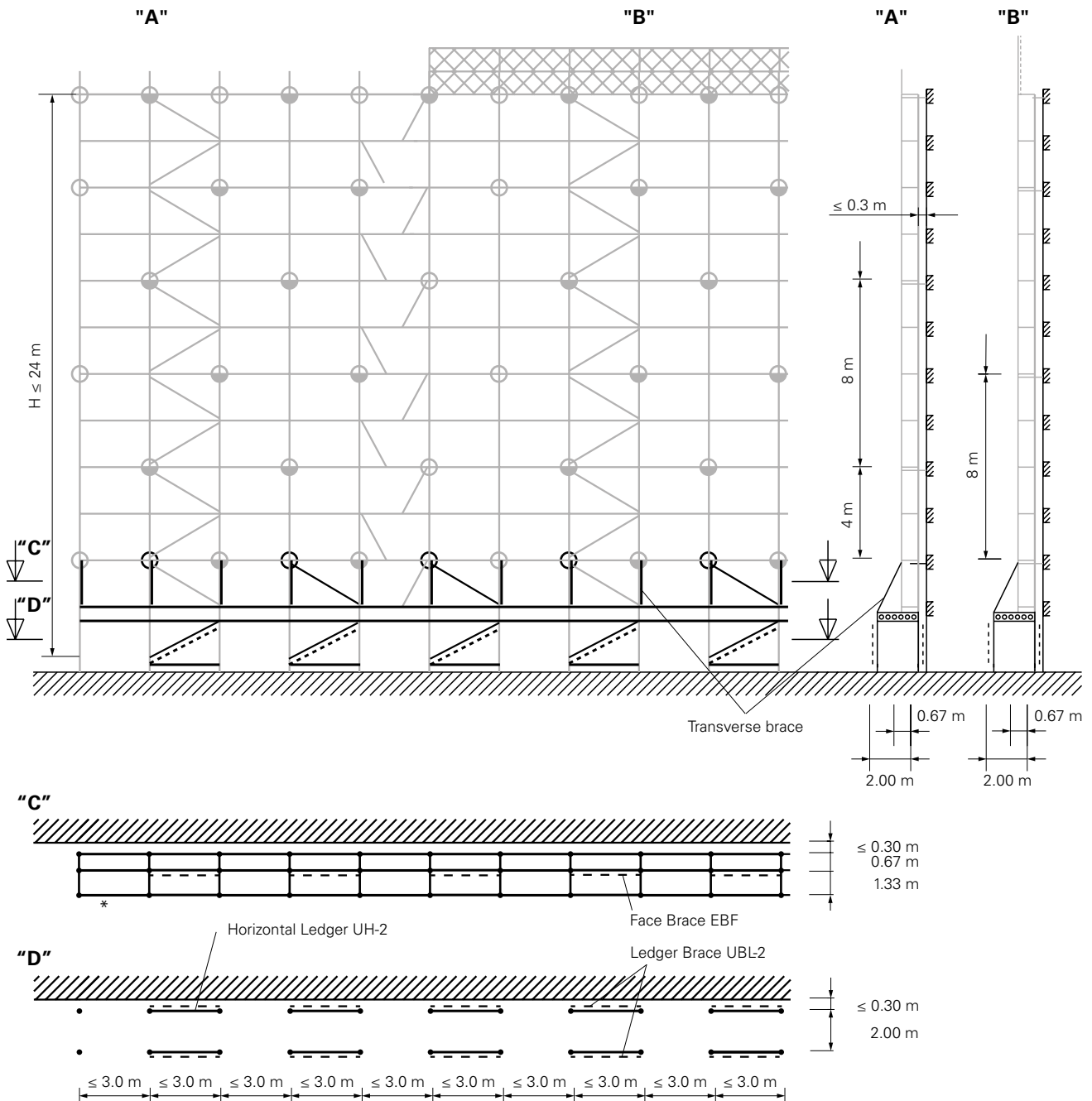
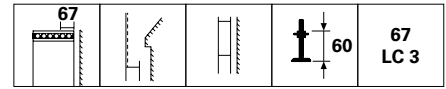

*On the multi girder, a total of five Horizontal Ledgers UH-2 are required for each bay. See Section "D6 Pavement gantry" on page 142 ff

- ⊕ Single-standard wall tie
- ⊙ Wall tie

F4 Tie pattern

Standard variant ≤ 24 m

Variante 1.5/LC3, pavement gantry

Standard configuration:
unclad scaffold in front of open or closed facade.

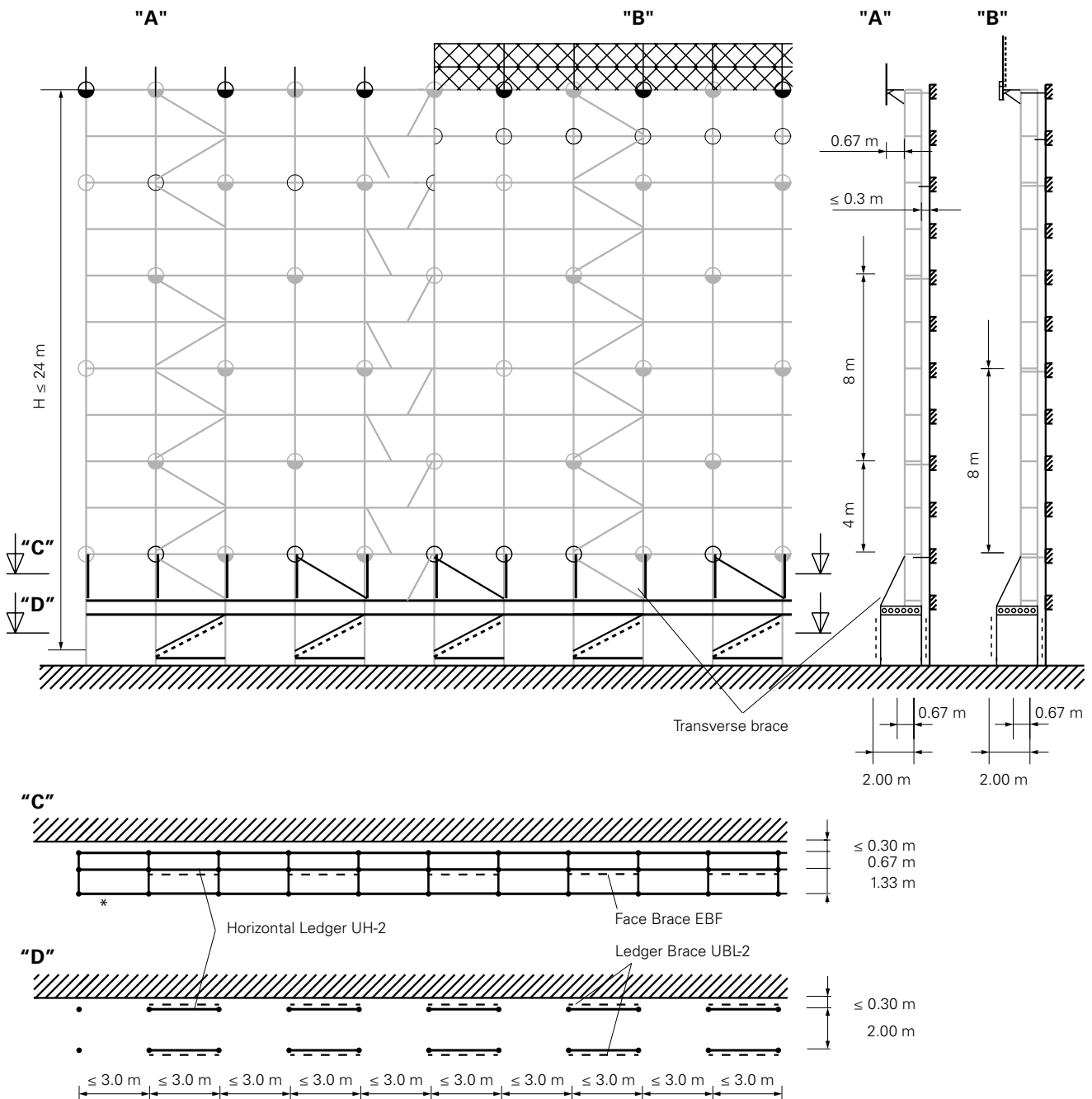
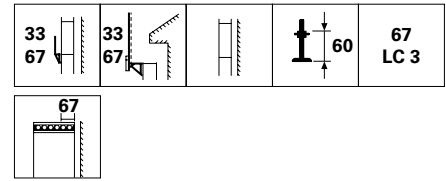

*On the multi girder, a total of five Horizontal Ledgers UH-2 are required for each bay. See Section "D6 Pavement gantry" on page 142 ff
Note: lateral protection components not shown.

- ⊕ Single-standard wall tie
- ⊙ Wall tie

F4 Tie pattern

Standard variant ≤ 24 m

Basic variant 2a/LC3

Standard configuration:
unclad scaffold in front of open or closed facade.

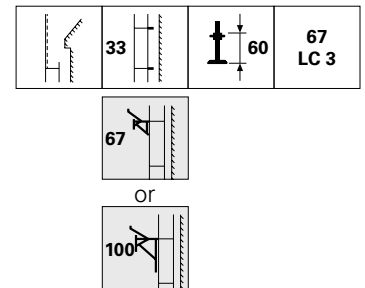

8 m offset tie pattern

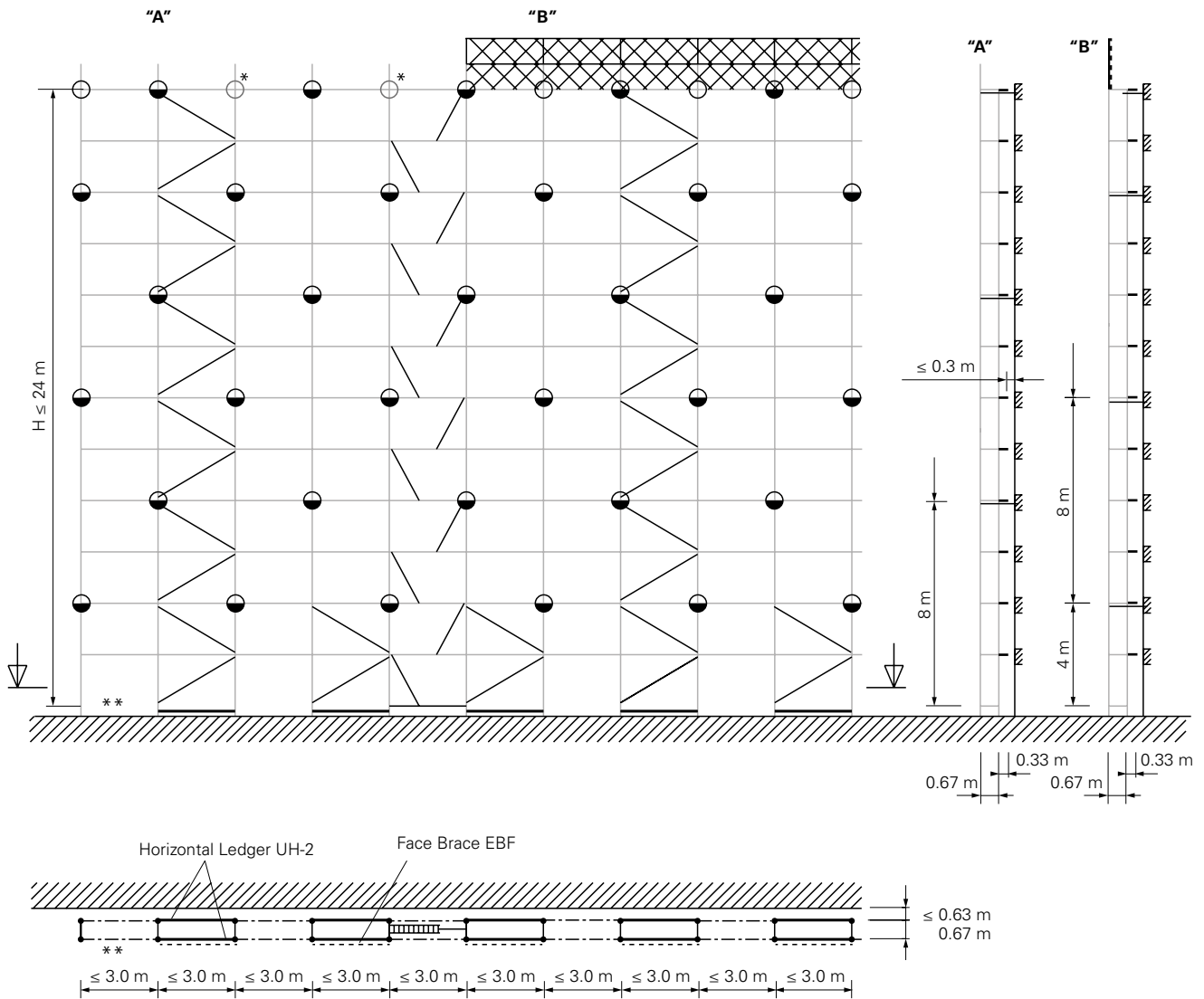

* Only required with partially open facade.
** If there are fewer than 4 bays, fit horizontal ledgers at the outside of each bay.
Note: lateral protection components not shown.

- ⊕ Single-standard wall tie
- Wall tie

Standard variant ≤ 24 m

Variant 2.1a/LC3

Protection roof execution

Take the following points into account in addition to the specified assembly guidelines for basic variant 2a.

Tie pattern

- Anchor the protection roof position in each frame column with a wall tie.
- for protection roof in scaffold level 2, establish the tie position above the protection roof with at least one single-standard wall tie.

Bracing

- No additional bracing required.

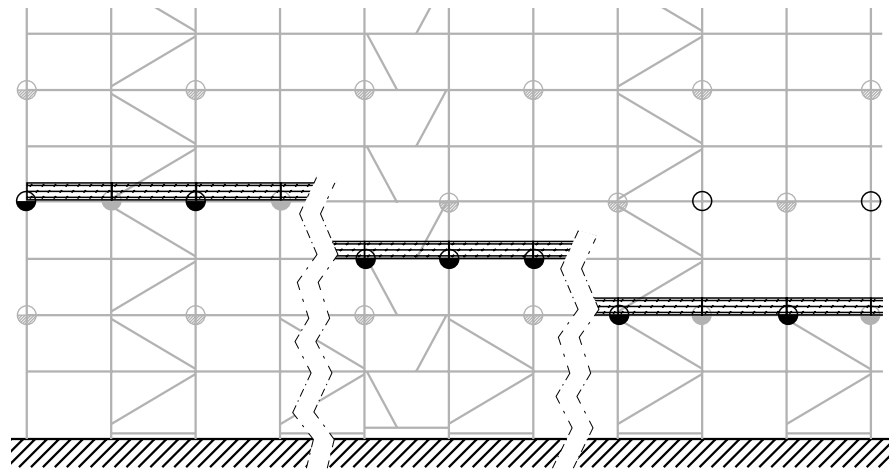

Note: lateral protection components not shown.

- ⊕ Single-standard wall tie
- Wall tie

F4 Tie pattern

Standard variant ≤ 24 m

Basic variant 2b/LC3

Standard configuration:
unclad scaffold in front of open or closed facade.

	33		67 LC 3
--	----	--	------------



OR



8 m offset tie pattern

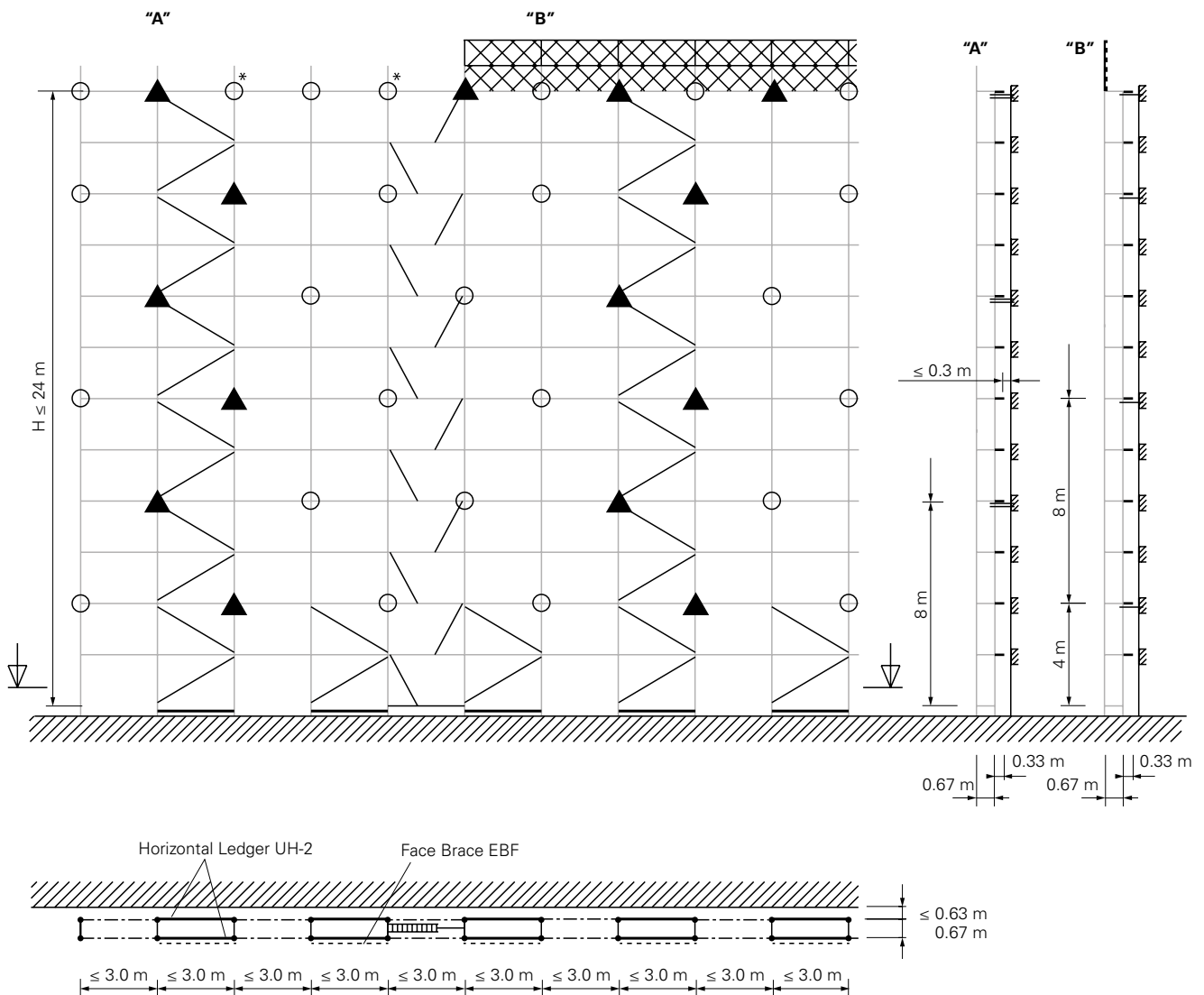

* Only required with partially open facade.

** If there are fewer than 4 bays, fit horizontal ledgers at the outside of each bay.

Note: lateral protection components not shown.

⊕ Single-standard wall tie

▲ Triangulated tie

Standard variant ≤ 24 m

Variant 2.1b/LC3

Protection roof execution

Take the following points into account in addition to the specified assembly guidelines for basic variant 2b.

Tie pattern

- Anchor the protection roof position in every second frame column with triangulated ties.
- Anchor all remaining frame columns with single-standard wall ties

Bracing

- No additional bracing required.

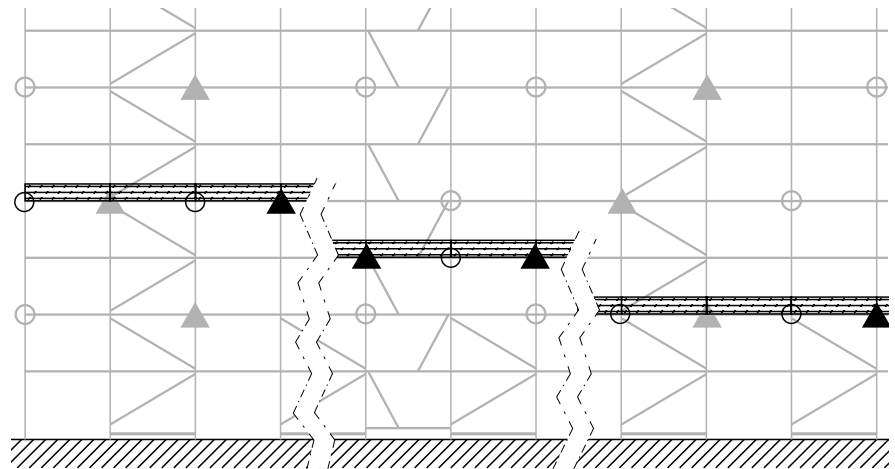

Note: lateral protection components not shown.

- ⊕ Single-standard wall tie
- ▲ Triangulated tie

F4 Tie pattern

Standard variant ≤ 24 m

Variant 2.2/LC3

Standard configuration:
unclad scaffold in front of open or closed facade.

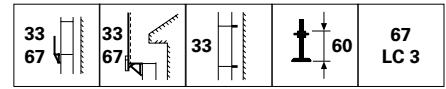

or

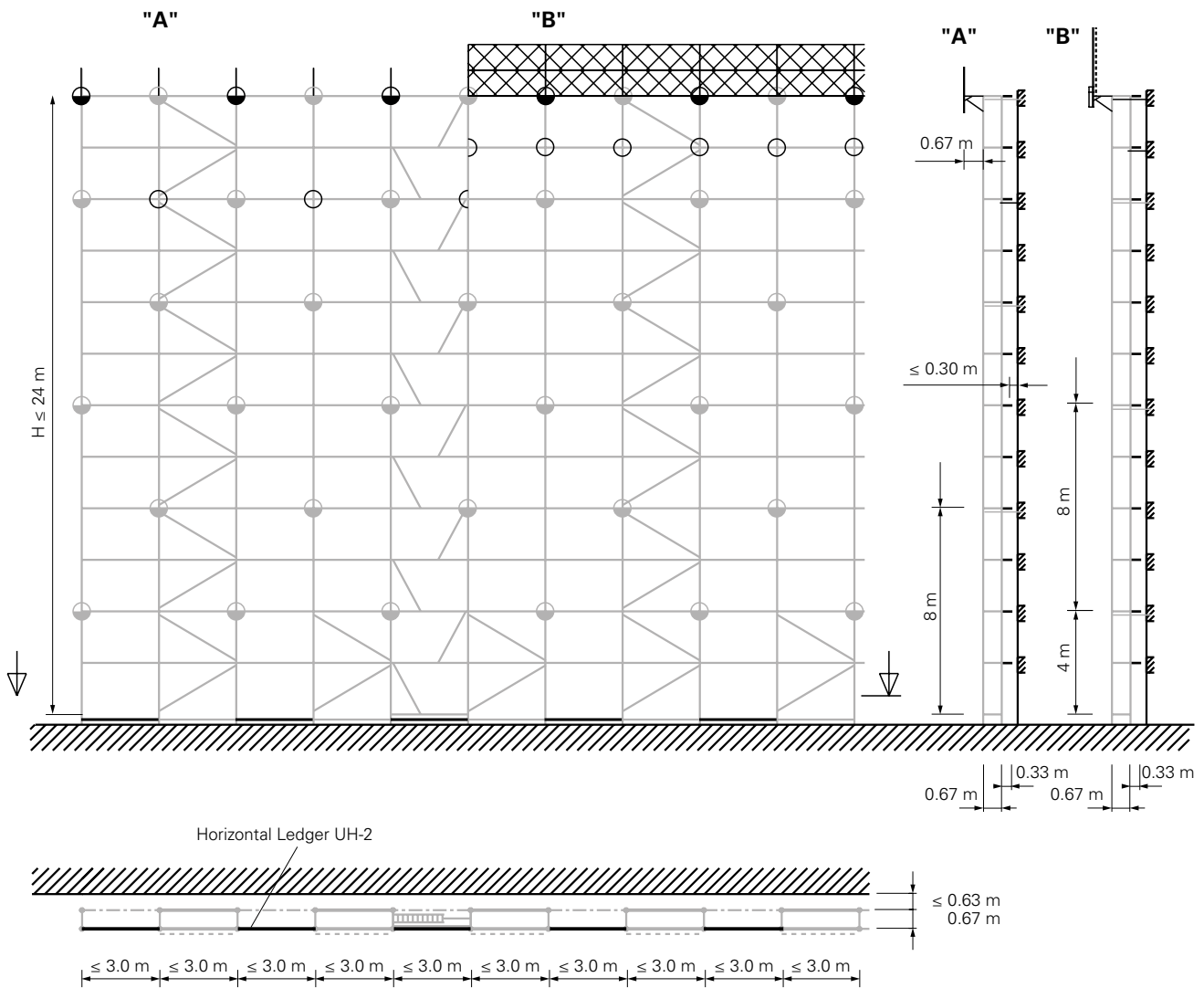

Note: lateral protection components not shown.

⊕ Single-standard wall tie

Standard variant ≤ 24 m

Variant 2.2/LC3

Protection roof execution

Take the following points into account in addition to the specified assembly guidelines for variant 2.2.

Tie pattern

- Anchor the protection roof position in each frame column with a wall tie.
- In each frame column, anchor the scaffold level below the protection roof position with a single-standard wall tie at the very least.
- If the protection roof is in scaffold level 4, then anchor scaffold level 2 in each frame column with a single-standard wall tie at the very least.

Bracing

- No additional bracing required.

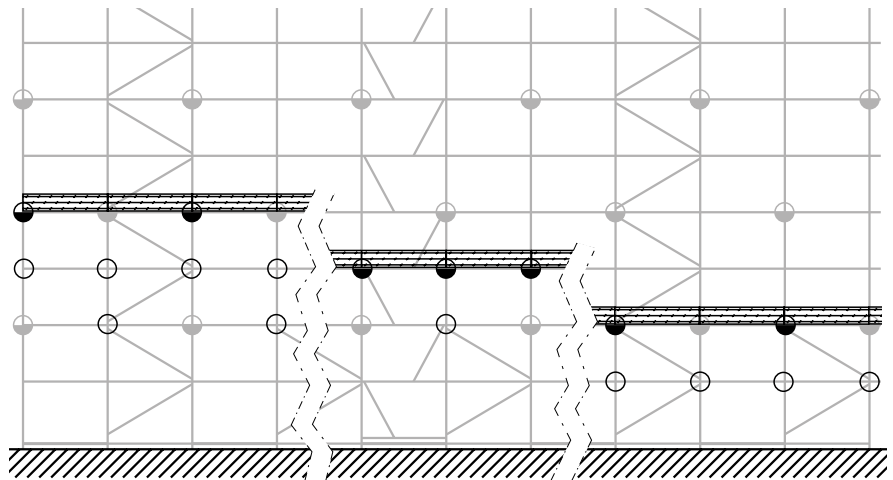

Easy 67

Note: lateral protection components not shown.

- ⊕ Single-standard wall tie
- Wall tie

F4 Tie pattern

Standard variant ≤ 24 m

Variante 2.3/LC3 – bridging 6 m (5 m)

Standard configuration:
unclad scaffold in front of open or closed facade.

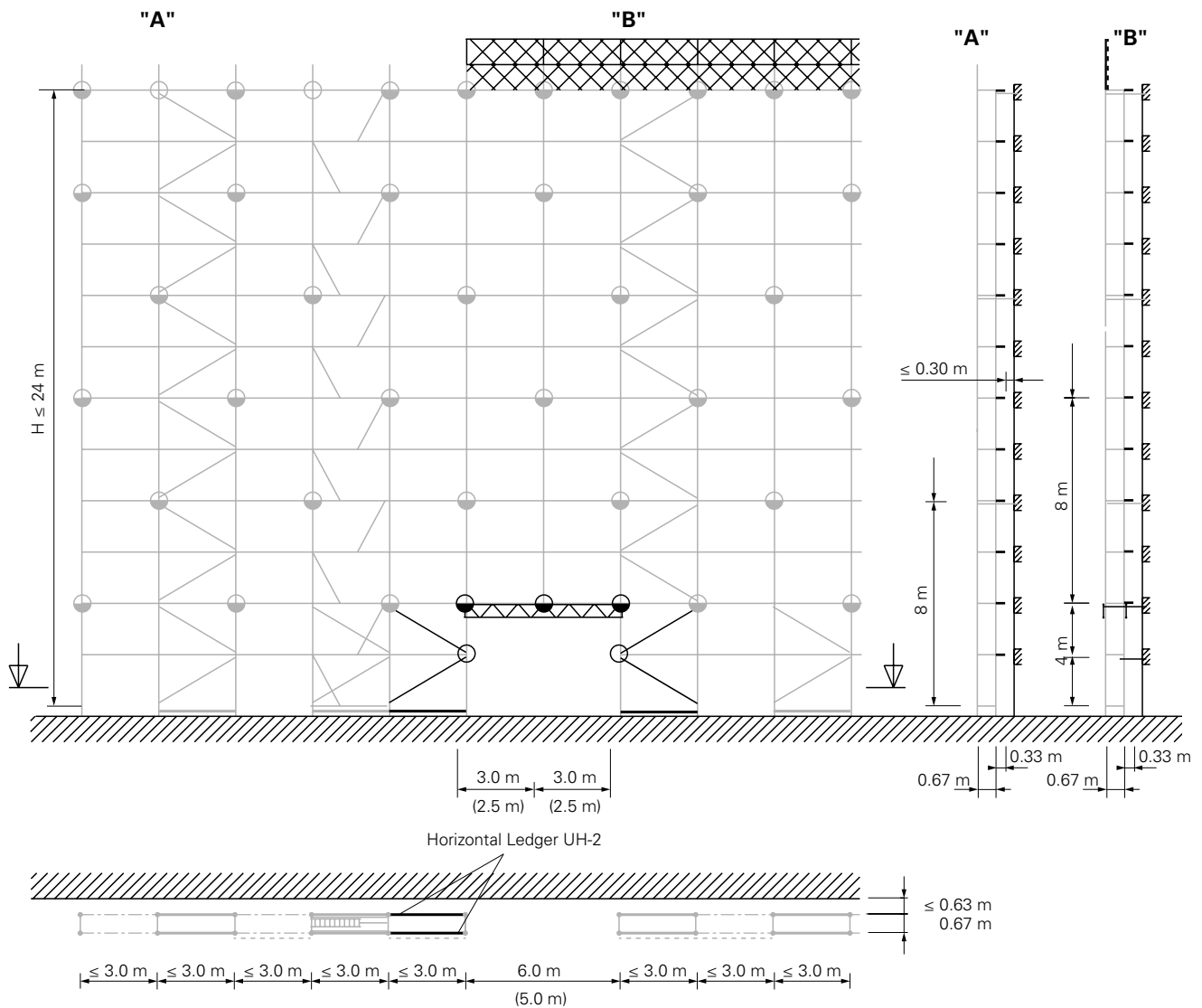
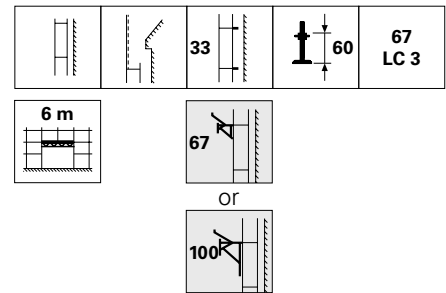

Note: lateral protection components not shown.

- ⊕ Single-standard wall tie
- ⊙ Wall tie

Standard variant ≤ 24 m

Variant 2.3/LC3

Protection roof execution

Take the following points into account in addition to the specified assembly guidelines for variant 2.3.



Tie pattern

- Anchor the protection roof position in each frame column with a wall tie.
- If the protection roof is in scaffold level 2, then anchor the tie position above it in each frame column with single-standard wall ties at the very least. Anchor the frame columns at the bridging of the first scaffold level with single-standard wall ties.
- If the protection roof is in scaffold level 4, then anchor the tie position above it in each frame column with single-standard wall ties at the very least.

Bracing

- No additional bracing required.

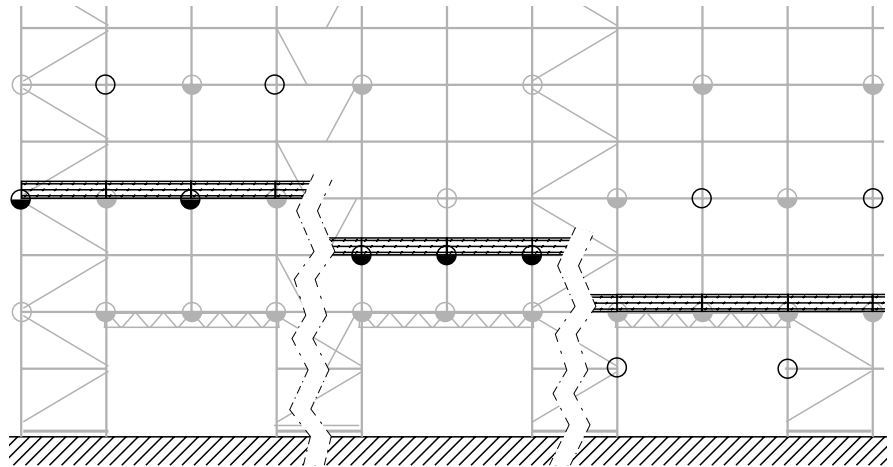

Note: lateral protection components not shown.

- ⊕ Single-standard wall tie
- ⊙ Wall tie

F4 Tie pattern

Standard variant ≤ 24 m

Variante 2.4/LC3 – bridging 6 m (5 m)

Standard configuration:
unclad scaffold in front of open or closed facade.

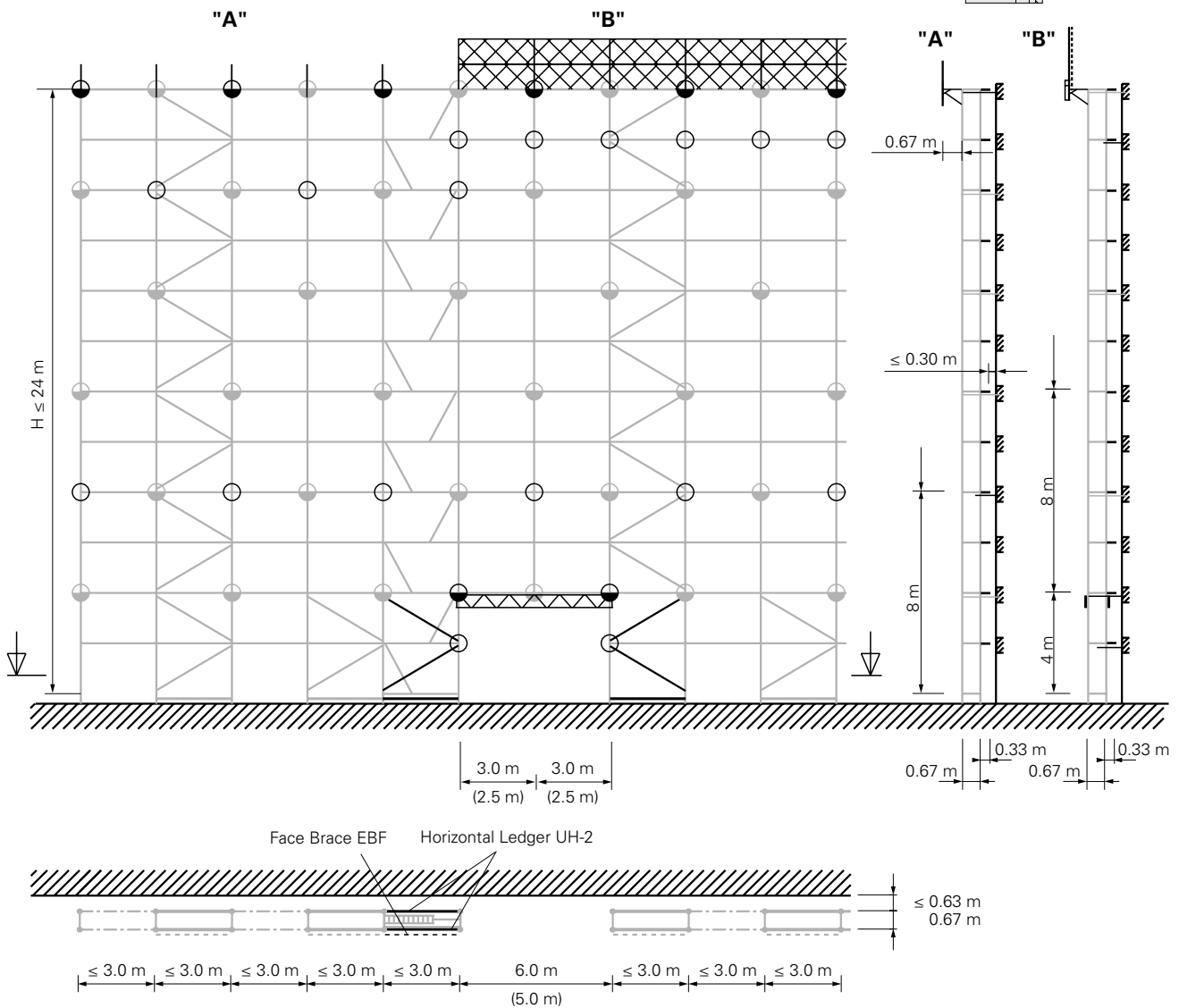
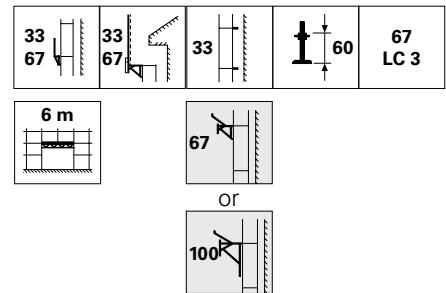

Note: lateral protection components not shown.

- ⊕ Single-standard wall tie
- ⊙ Wall tie

Standard variant ≤ 24 m

Variant 2.4/LC3

Protection roof execution

Take the following points into account in addition to the specified assembly guidelines for variant 2.4.



Tie pattern

- Anchor the protection roof position in each frame column with a wall tie.
- If the protection roof is in scaffold level 2 or 3, then anchor the tie position above it in each frame column with a single-standard wall tie at the very least. Already included in variant 2.4.
- If the protection roof is in scaffold level 2, then anchor scaffold level 1 in each frame column with a single-standard wall tie.
- If the protection roof is in scaffold level 4, then anchor scaffold level 3 in each frame column with a single-standard wall tie.

Bracing

- If the protection roof is in scaffold level 3 or 4, then fit a horizontal ledger onto the outside and inside of the base standard in each bay.

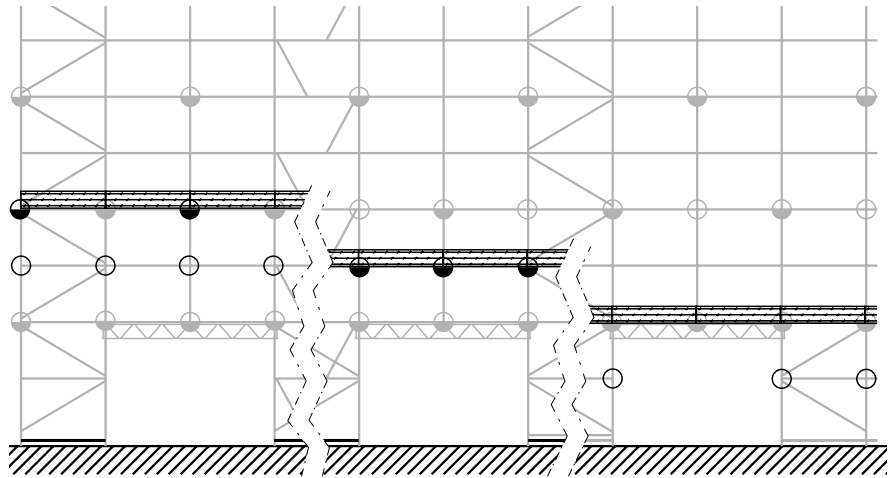

Easy 67

Note: lateral protection components not shown.

- ⊕ Single-standard wall tie
- ⊙ Wall tie

F4 Tie pattern



Standard variant ≤ 24 m

Variante 2.5/LC3, pavement gantry

Standard configuration:
unclad scaffold in front of open or closed facade.

		33		60	67 LC 3
--	--	----	--	----	------------

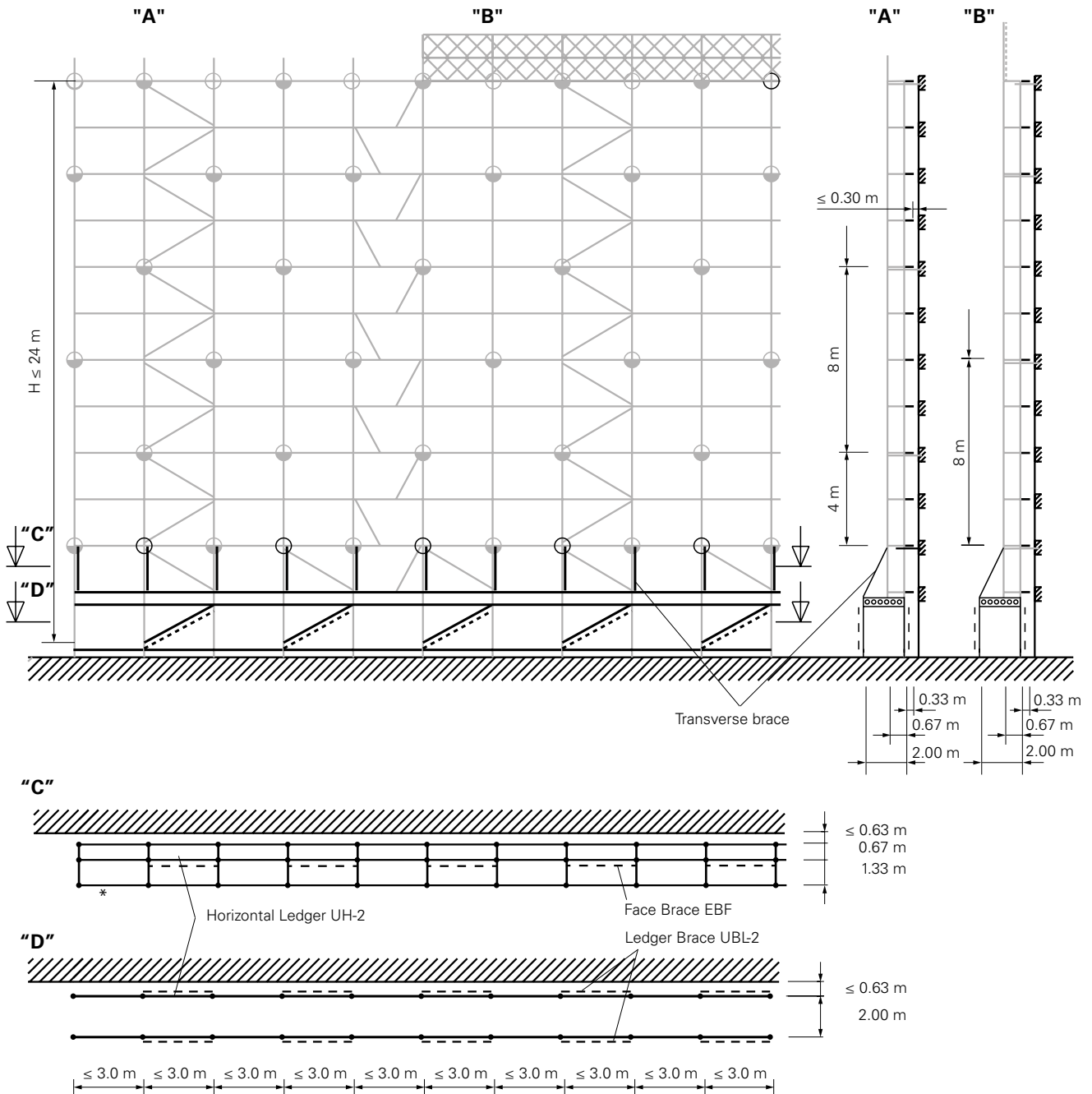

*On the multi girder, a total of five Horizontal Ledgers UH-2 are required for each bay. See Section "D6 Pavement gantry" on page 142 ff
Note: lateral protection components not shown.

- ⊕ Single-standard wall tie
- ⊙ Wall tie

F4 Tie pattern

Standard variant ≤ 24 m

Variante 2.6/LC3, pavement gantry

Standard configuration:
unclad scaffold in front of open or closed facade.

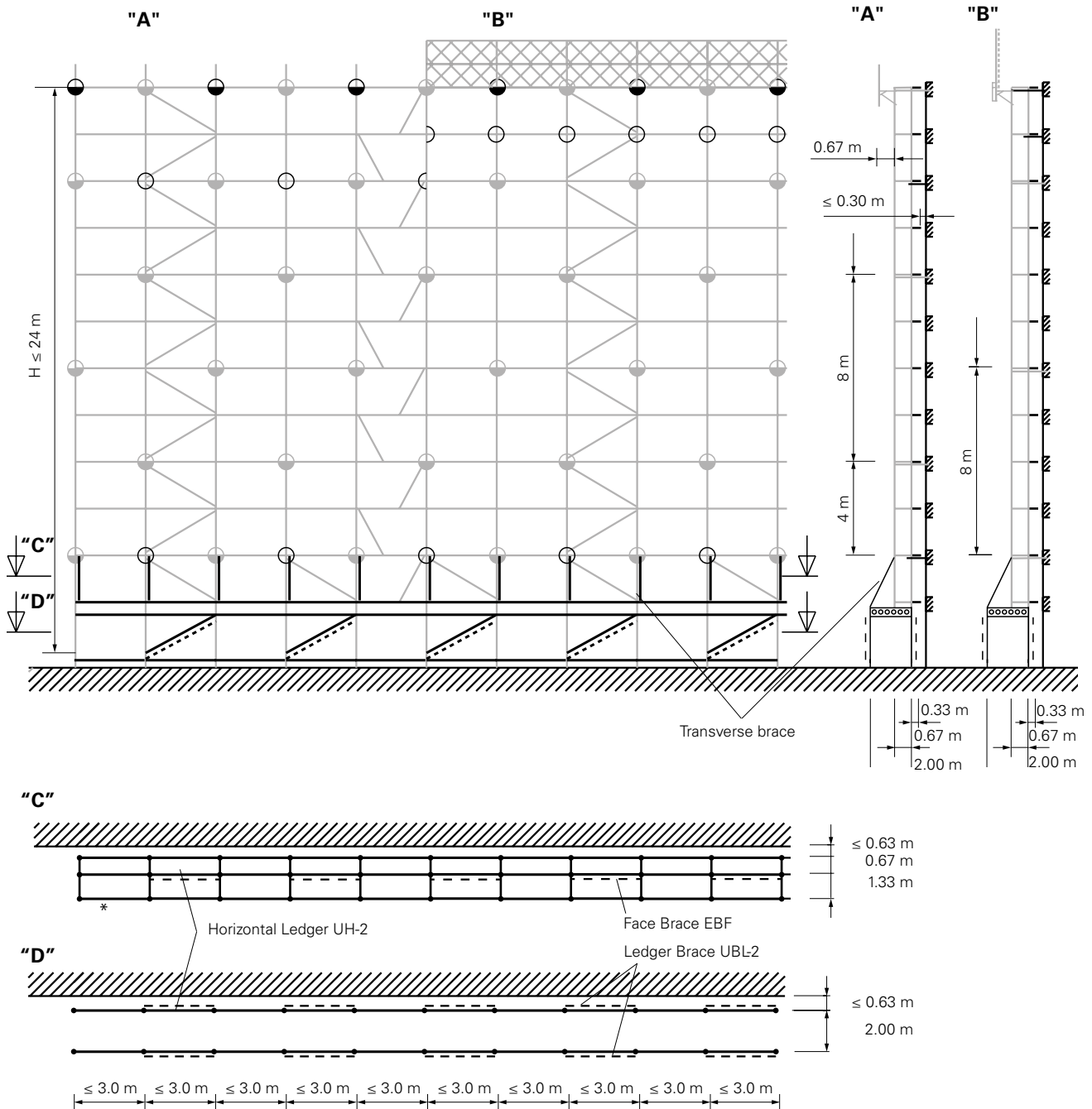
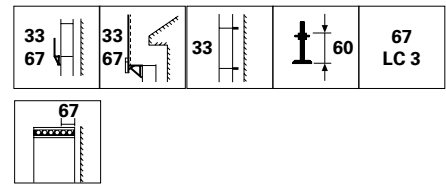

*On the multi girder, a total of five Horizontal Ledgers UH-2 are required for each bay. See Section "D6 Pavement gantry" on page 142 ff.
Note: lateral protection components not shown.

- ⊕ Single-standard wall tie
- ⊙ Wall tie

Standard variant ≤ 24 m

Variante 2.7/LC3, topmost level not anchored

Standard configuration:
 unclad scaffold in front of open or closed facade.
 Gaps between buildings, uplifting wind forces.

33 	67 LC 3
--------	------------

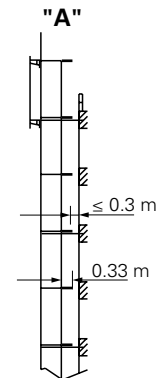
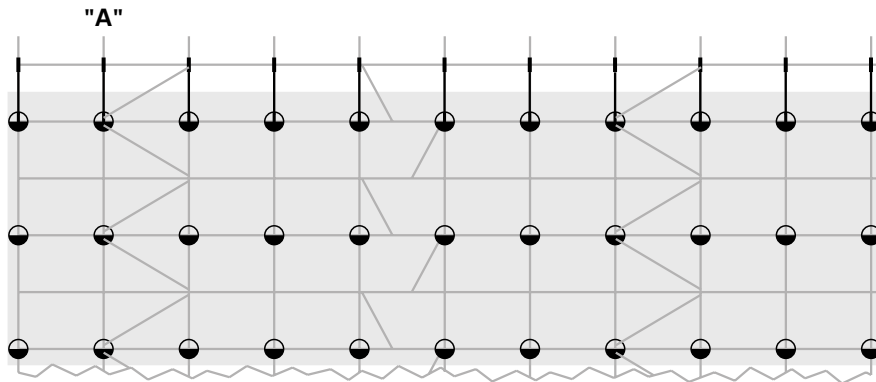

In the case of scaffolds that grow in line with the building, for example, the top scaffold level may be erected without anchoring.

- The second scaffold level from the top must be anchored at each frame column using wall ties.
- The joints of the Easy standards (22) on the three uppermost scaffold levels must be connected with locking pins (19) so that they are tension-proof.
- Brace both upper scaffold levels with a console bracket backpack.
- Secure both Console Brackets ECM 33 (62 + 62a) on the outer leg with Guardrail Coupling EPR (58) to prevent lifting, see Section "Protection roof on external console bracket" on page 130 f.
- Connect the upright joints between the console brackets (62 + 62a) and the Tube EVR 150 (18) with locking pins (19) so that they are tension-proof.

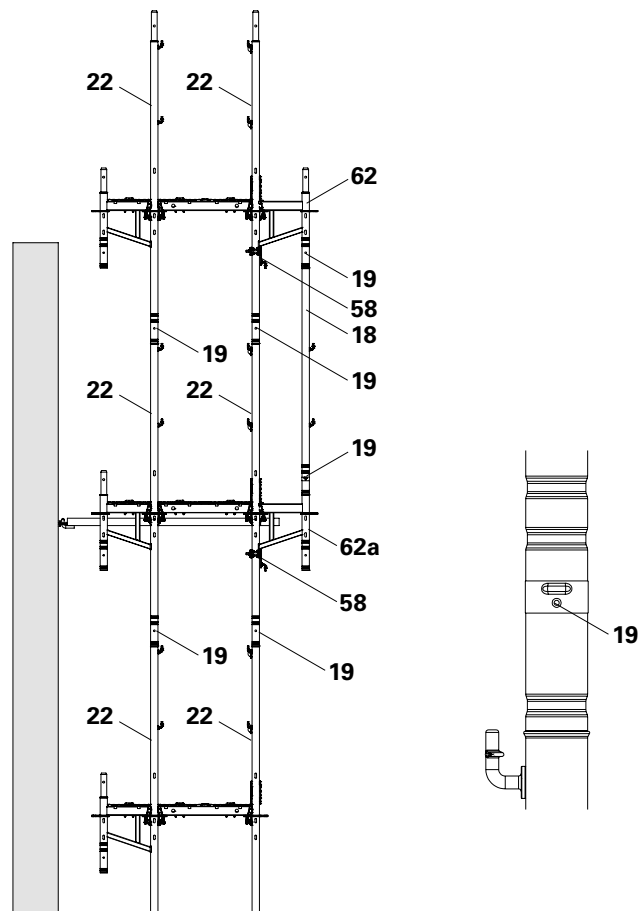

Note: lateral protection components not shown.

- ⊕ Single-standard wall tie
- ⊕ Wall tie

F4 Tie pattern

Standard variant ≤ 24 m

Basic variant 3/LC3

Standard configuration:
netting in front of closed facade.

Netting					67 LC 3
---------	--	--	--	--	------------



OR



8 m offset tie pattern

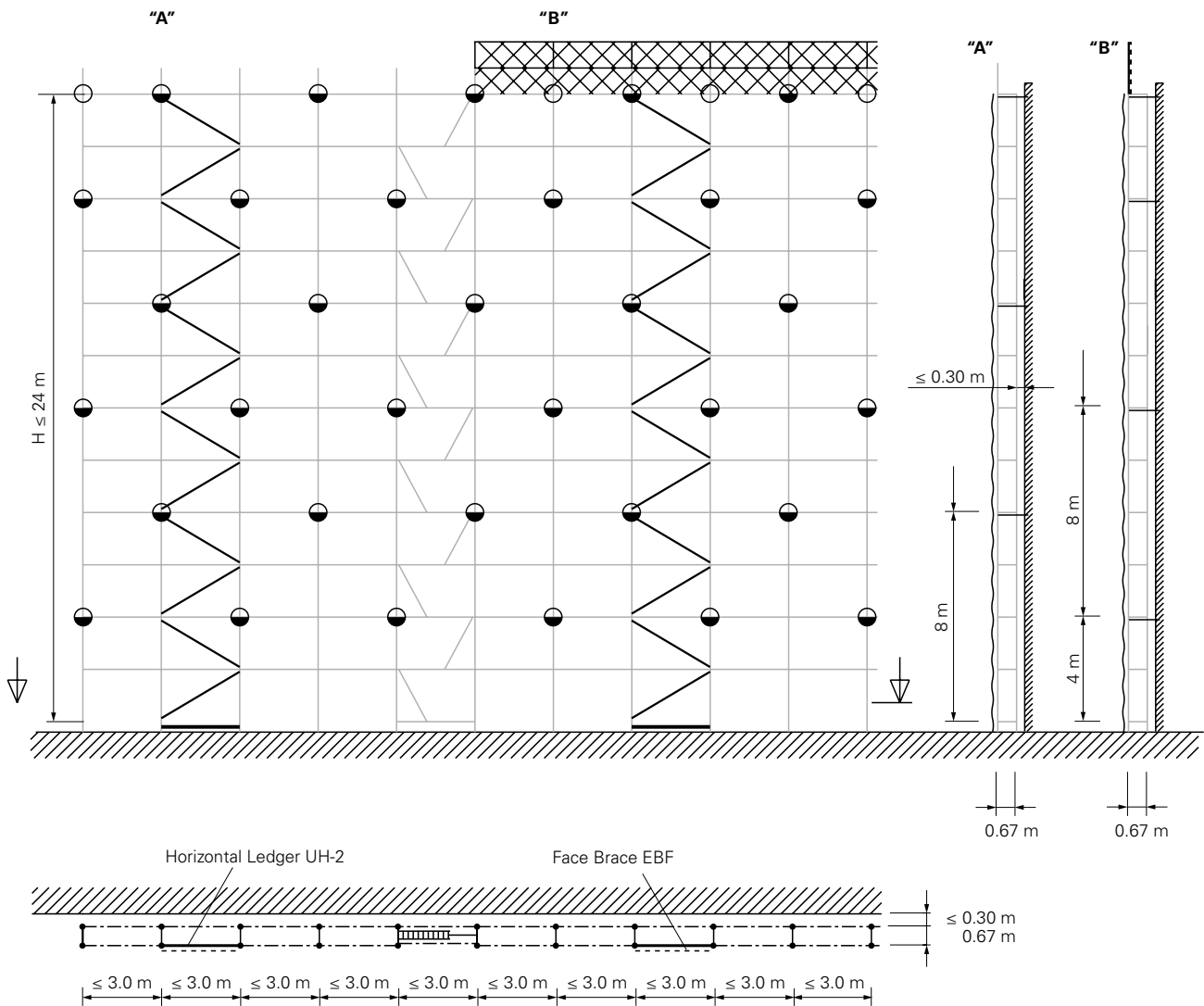

Note: lateral protection components not shown.

Wall tie

Standard variant ≤ 24 m

Basic variant 3/LC3

Protection roof execution

Take the following points into account in addition to the specified assembly guidelines for basic variant 3.

Tie pattern

- Anchor the protection roof position in each frame column with a wall tie.

Bracing

- No additional bracing required.

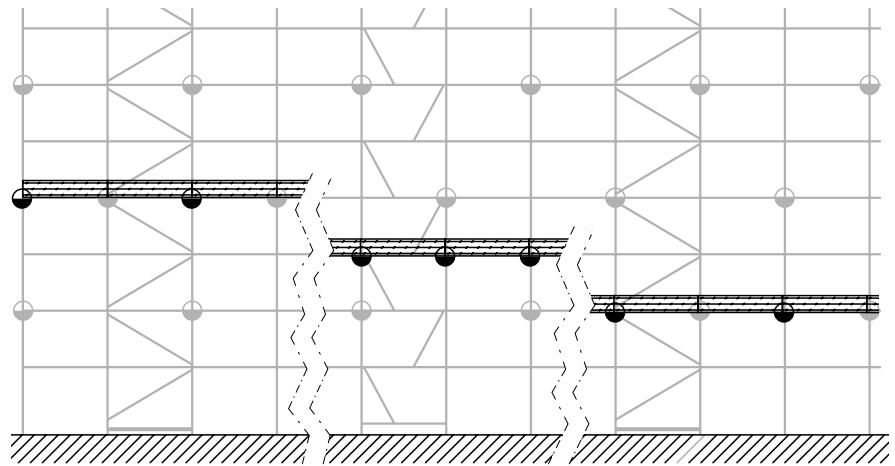

Note: lateral protection components not shown.

- ⊕ Single-standard wall tie
- ⊙ Wall tie

F4 Tie pattern

Standard variant ≤ 24 m

Variante 3.1/LC3

Standard configuration:
netting in front of closed facade.

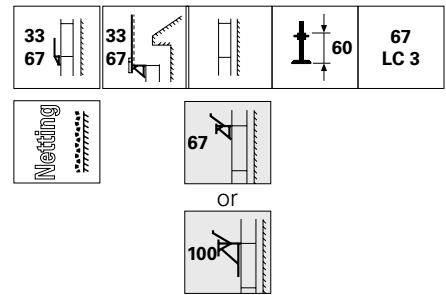

8 m offset tie pattern

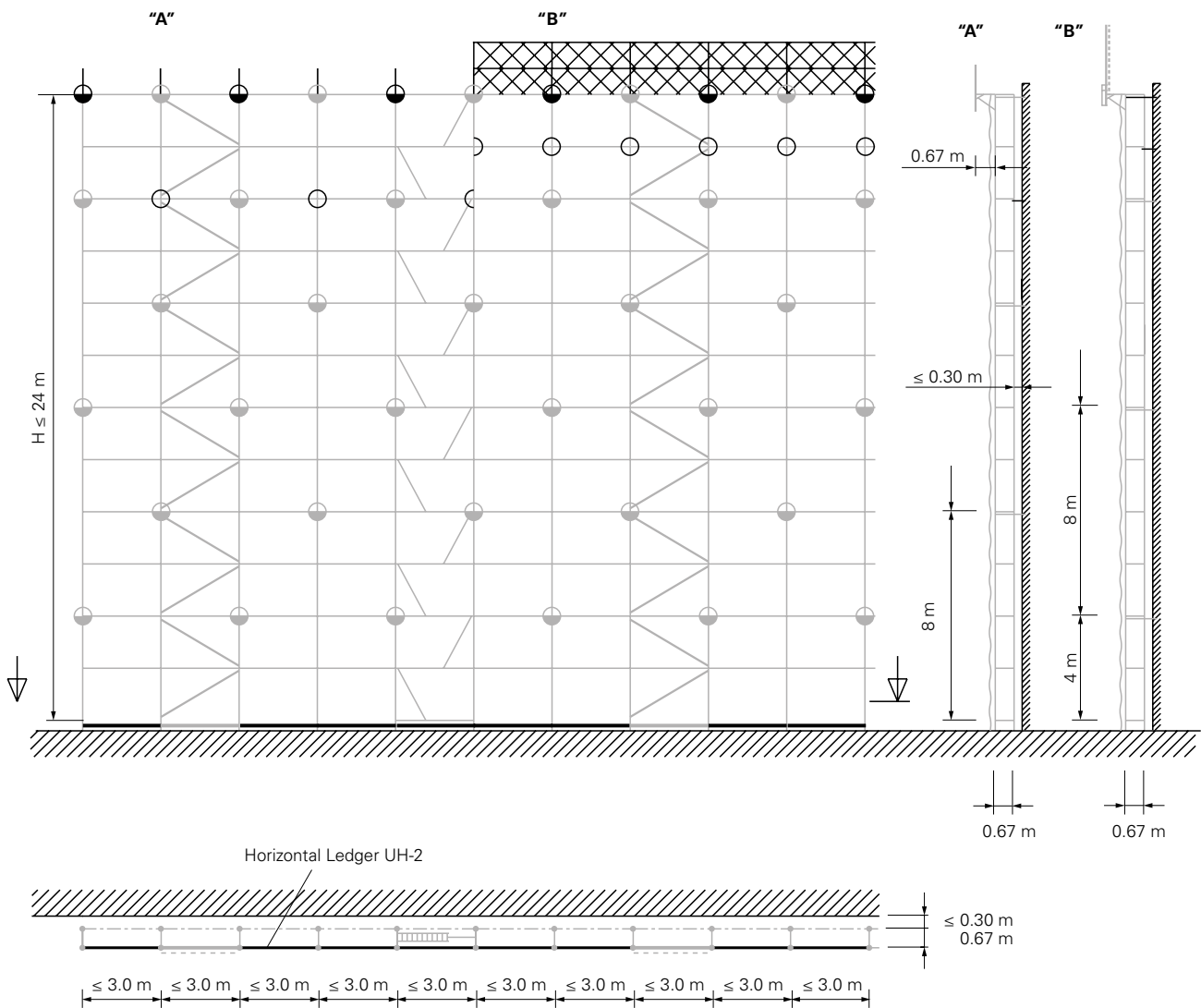

Note: lateral protection components not shown.

- ⊕ Single-standard wall tie
- Wall tie

Standard variant ≤ 24 m

Variant 3.1/LC3

Protection roof execution

Take the following points into account in addition to the specified assembly guidelines for variant 3.1.

Tie pattern

- Anchor the protection roof position in each frame column with a wall tie.
- If the protection roof is in the second scaffold level, then anchor the tie position above it in each frame column with a single-standard wall tie at the very least.

Bracing

- No additional bracing required.

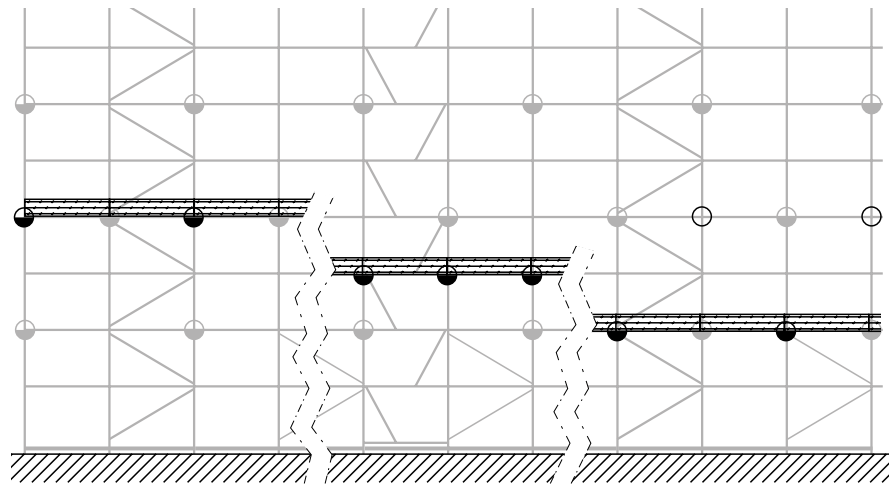

Note: lateral protection components not shown.

- ⊕ Single-standard wall tie
- Wall tie

F4 Tie pattern

Standard variant ≤ 24 m

Variante 3.2/LC3

Standard configuration:
netting in front of closed facade.

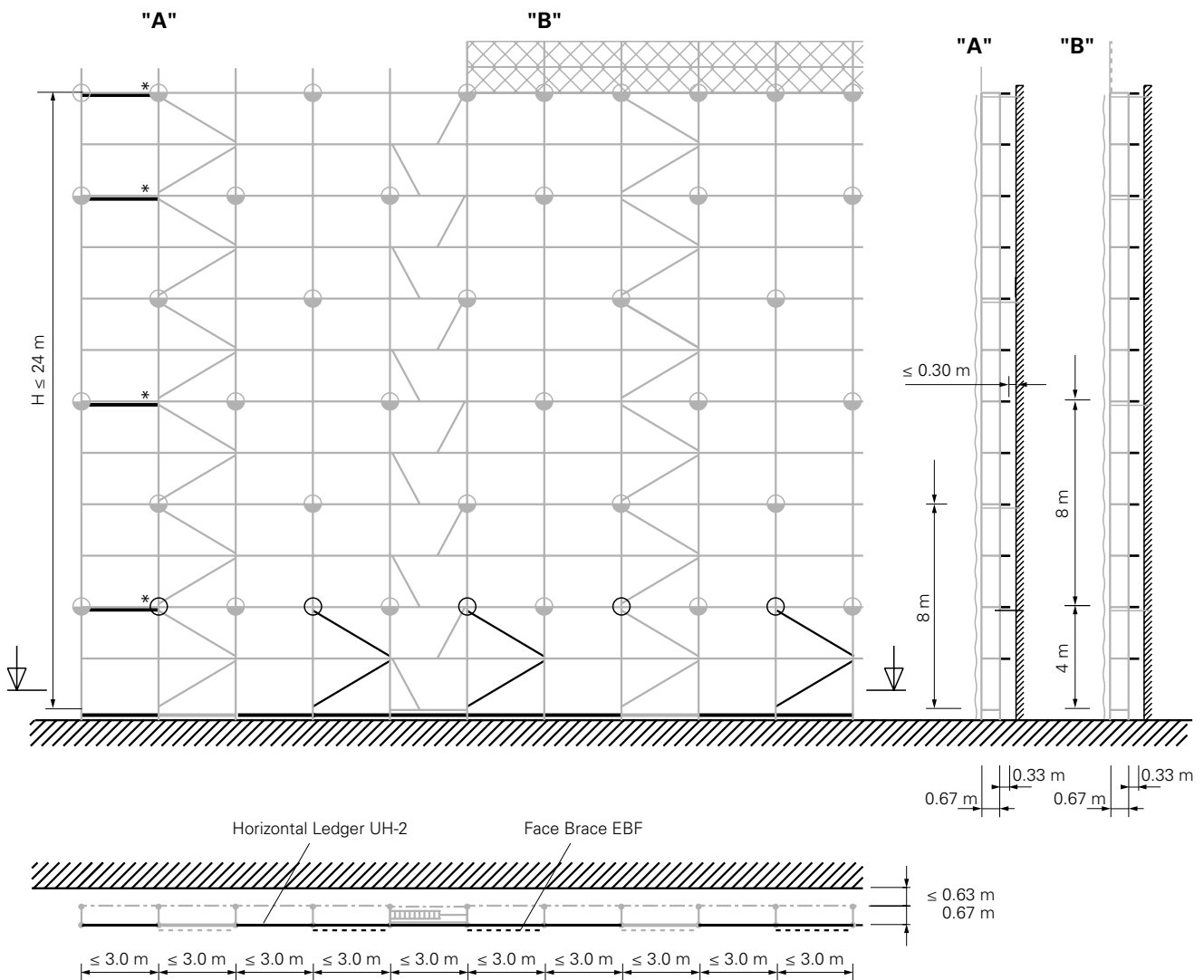
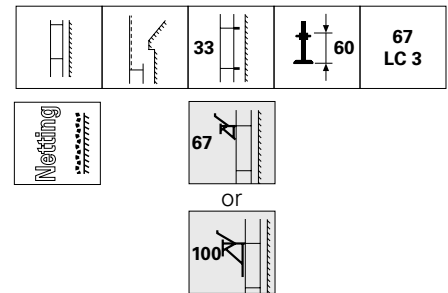

* If the edge standard is anchored, then fit a horizontal ledger onto the inner standard.
Note: lateral protection components not shown.

- ⊕ Single-standard wall tie
- Wall tie

Standard variant ≤ 24 m

Variant 3.2/LC3

Protection roof execution

Take the following points into account in addition to the specified assembly guidelines for variant 3.2.



Tie pattern

- Anchor the protection roof position in each frame column with a wall tie.
- Anchor the tie position above it in each frame column with a single-standard wall tie at the very least.

Bracing

- No additional bracing required.

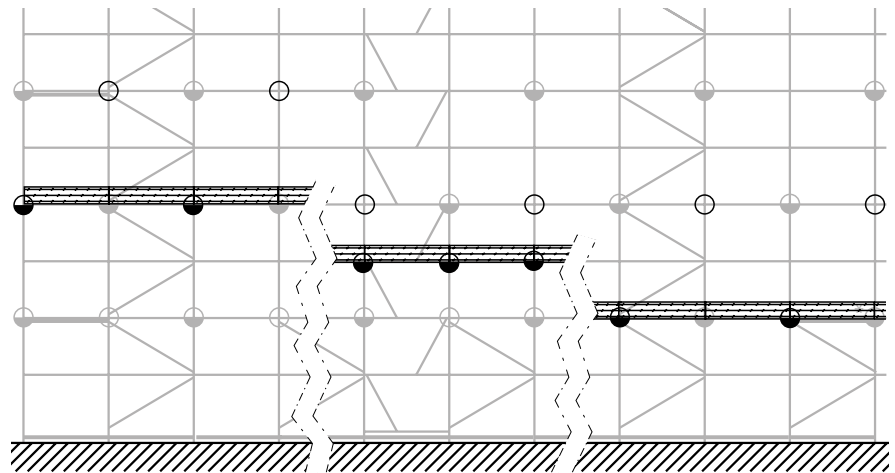

Easy 67

Note: lateral protection components not shown.

- ⊕ Single-standard wall tie
- Wall tie

F4 Tie pattern

Standard variant ≤ 24 m

Variant 3.3/LC3

Standard configuration:
netting in front of closed facade.

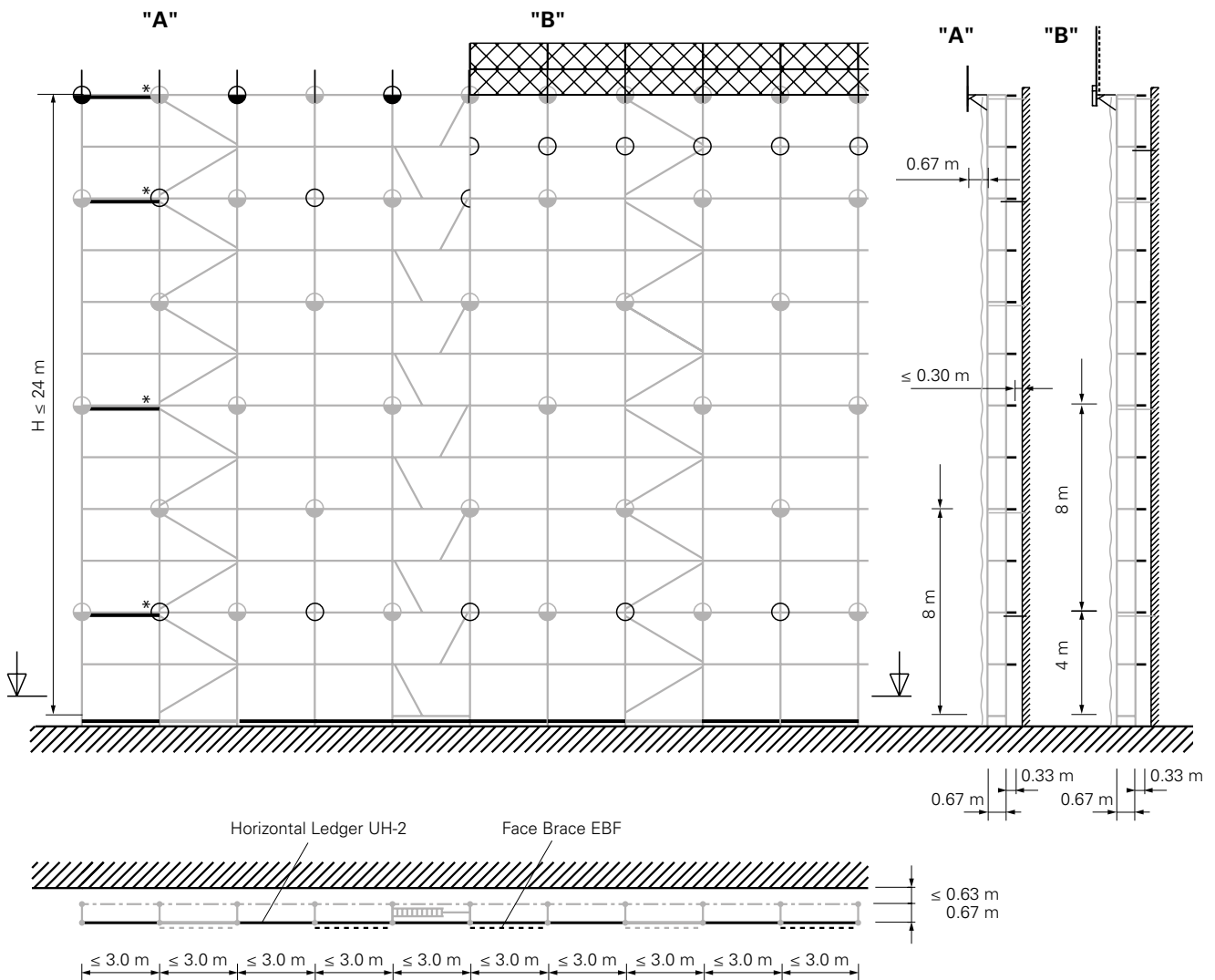
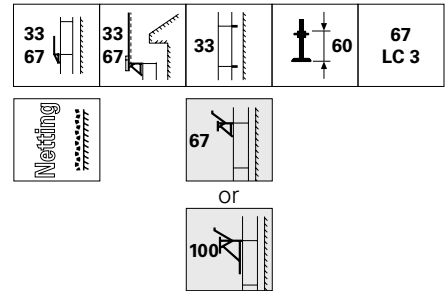

* If the edge standard is anchored, then fit a horizontal ledger onto the inner standard.
Note: lateral protection components not shown.

- ⊕ Single-standard wall tie
- Wall tie

Standard variant ≤ 24 m

Variant 3.3/LC3

Protection roof execution

Take the following points into account in addition to the specified assembly guidelines for variant 3.3.

Tie pattern

- Anchor the protection roof position in each frame column with a wall tie.
- Anchor the second scaffold level in each frame column with wall ties.
- In each frame column, anchor the scaffold level below the protection roof position with a single-standard wall tie at the very least.

Bracing

- No additional bracing required.

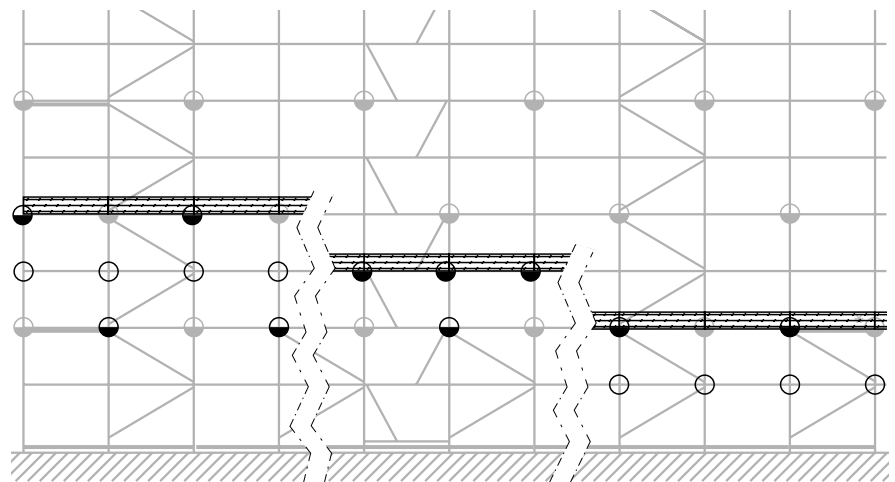

Easy 67

Note: lateral protection components not shown.

- ⊕ Single-standard wall tie
- Wall tie

F4 Tie pattern

Standard variant ≤ 24 m

Basic variant 4a/LC3

Standard configuration:
netting in front of open facade.

Netting 67 100			60	67 LC 3



Or



4 m offset tie pattern

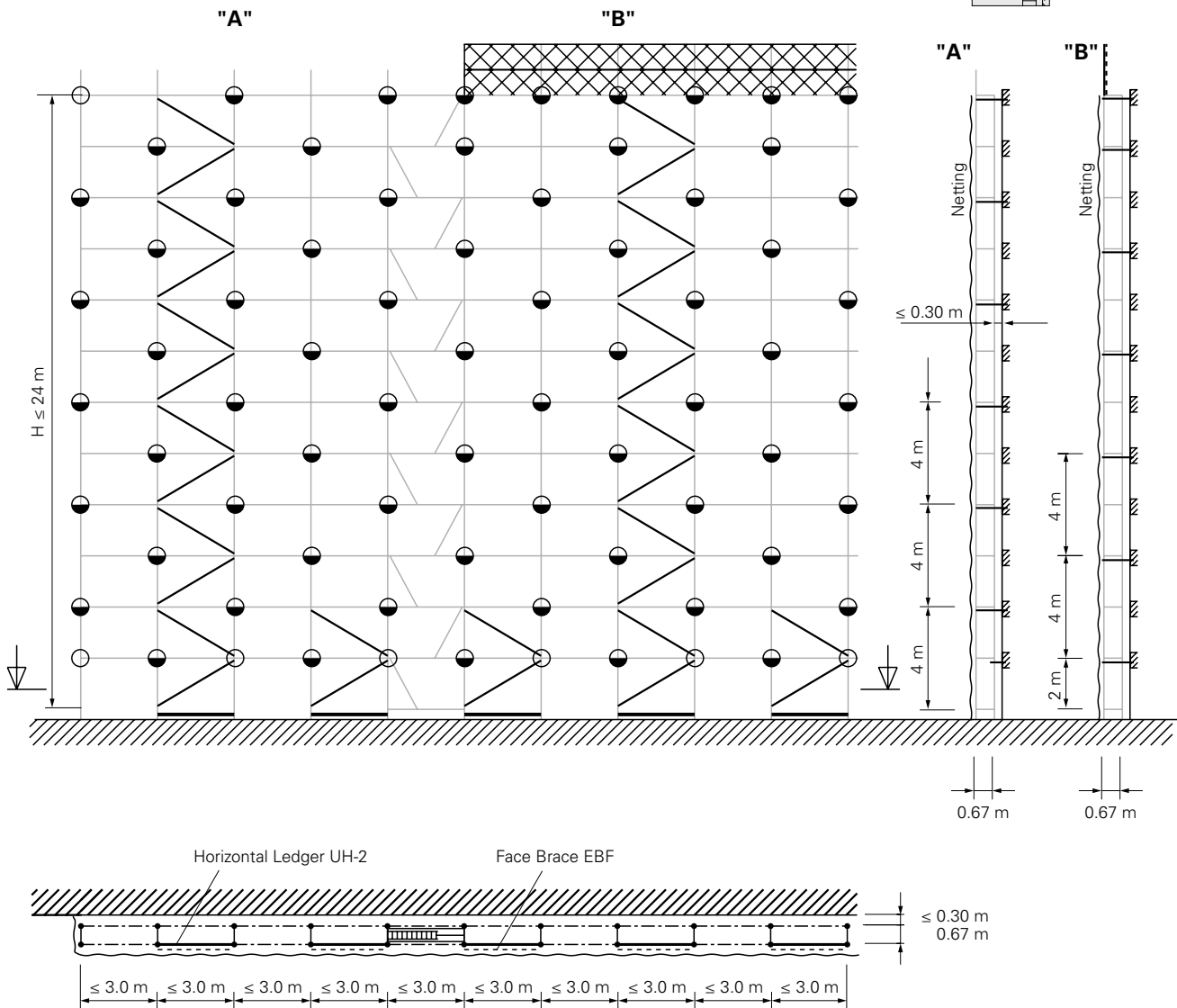

Note: lateral protection components not shown.

- Single-standard wall tie
- Wall tie

Standard variant ≤ 24 m

Basic variant 4a/LC3

Protection roof execution

Take the following points into account in addition to the specified assembly guidelines for basic variant 4a.

Tie pattern

- Anchor the protection roof position in each frame column with a wall tie.

Bracing

- No additional bracing required.

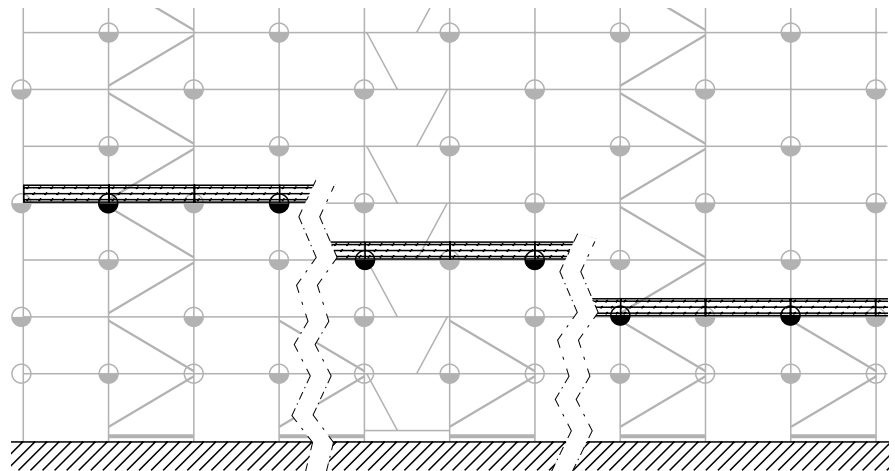

Note: lateral protection components not shown.

- ⊕ Single-standard wall tie
- Wall tie

F4 Tie pattern

Standard variant ≤ 24 m

Basic variant 4b/LC3

Standard configuration:
netting in front of open facade.

Netting 67 100			67 LC 3
----------------------	--	--	------------



or



4 m offset tie pattern

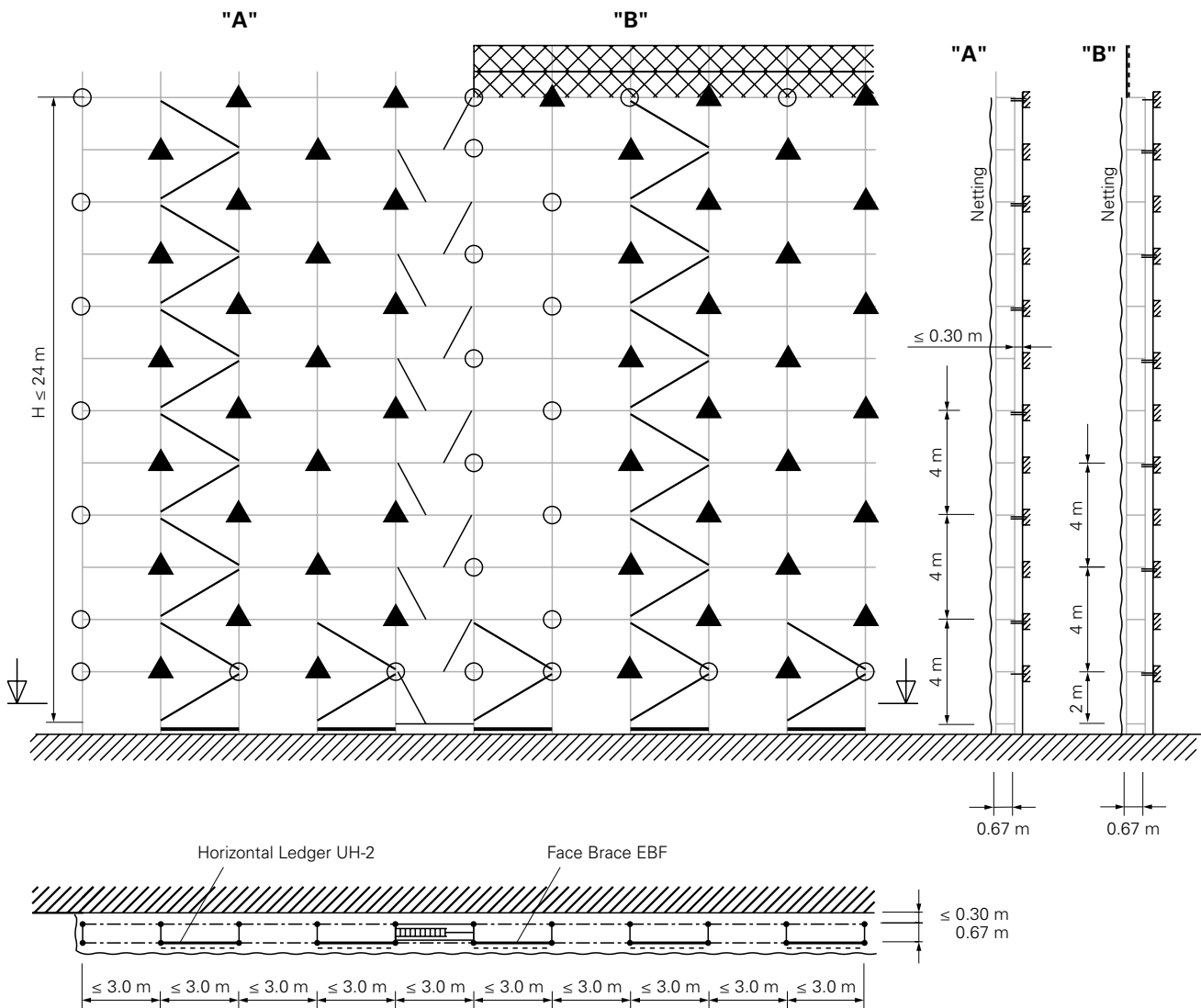

Note: lateral protection components not shown.

- Single-standard wall tie
- Triangulated tie

Standard variant ≤ 24 m

Basic variant 4b/LC3

Protection roof execution

Take the following points into account in addition to the specified assembly guidelines for basic variant 4a.

Tie pattern

- Anchor the protection roof position in every second frame column with triangulated ties.
- Anchor remaining frame columns with single-standard wall ties.

Bracing

- No additional bracing required.

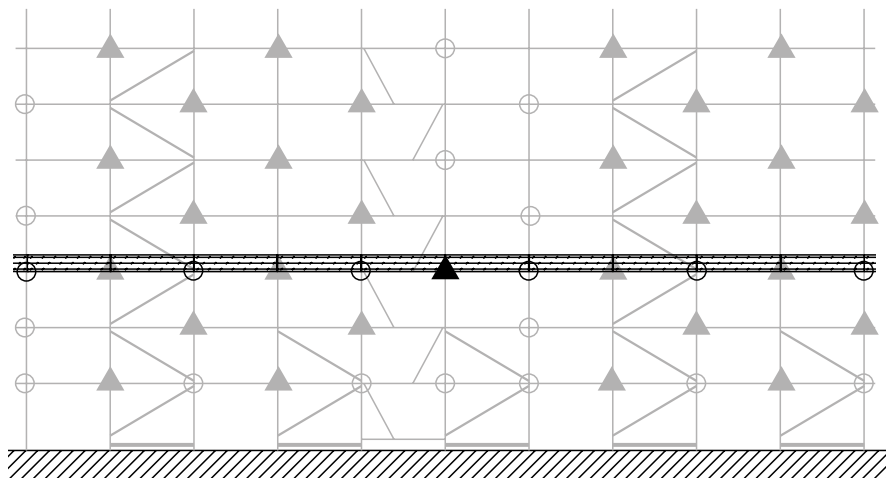
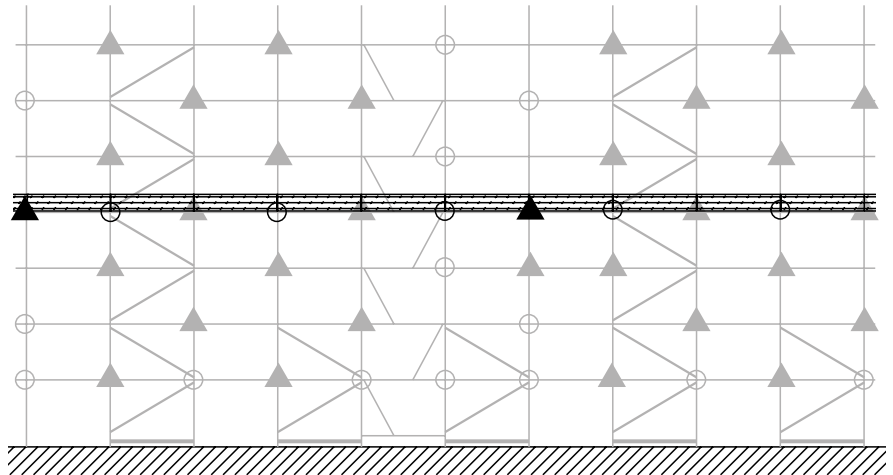

Note: lateral protection components not shown.

⊕ Single-standard wall tie

▲ Triangulated tie

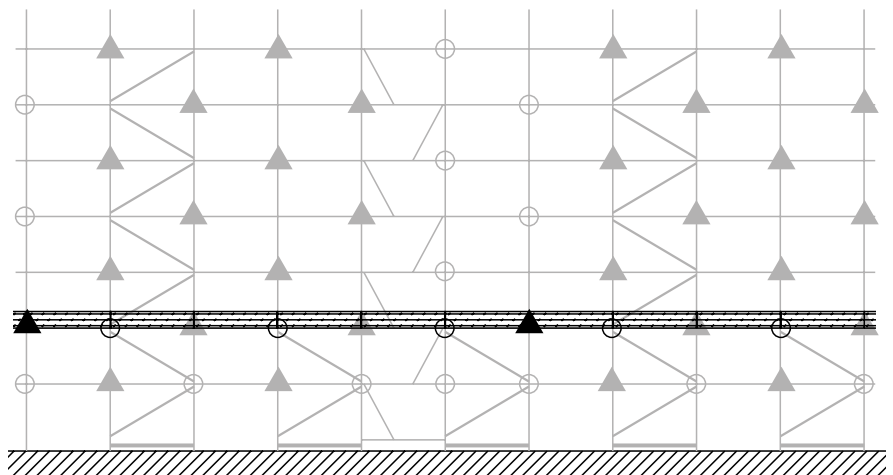

F4 Tie pattern

Standard variant ≤ 24 m

Variante 4.1/LC3

Standard configuration:
netting in front of open facade.

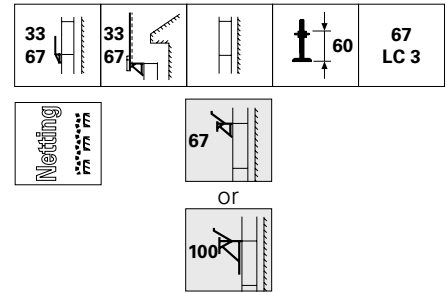

4 m offset tie pattern

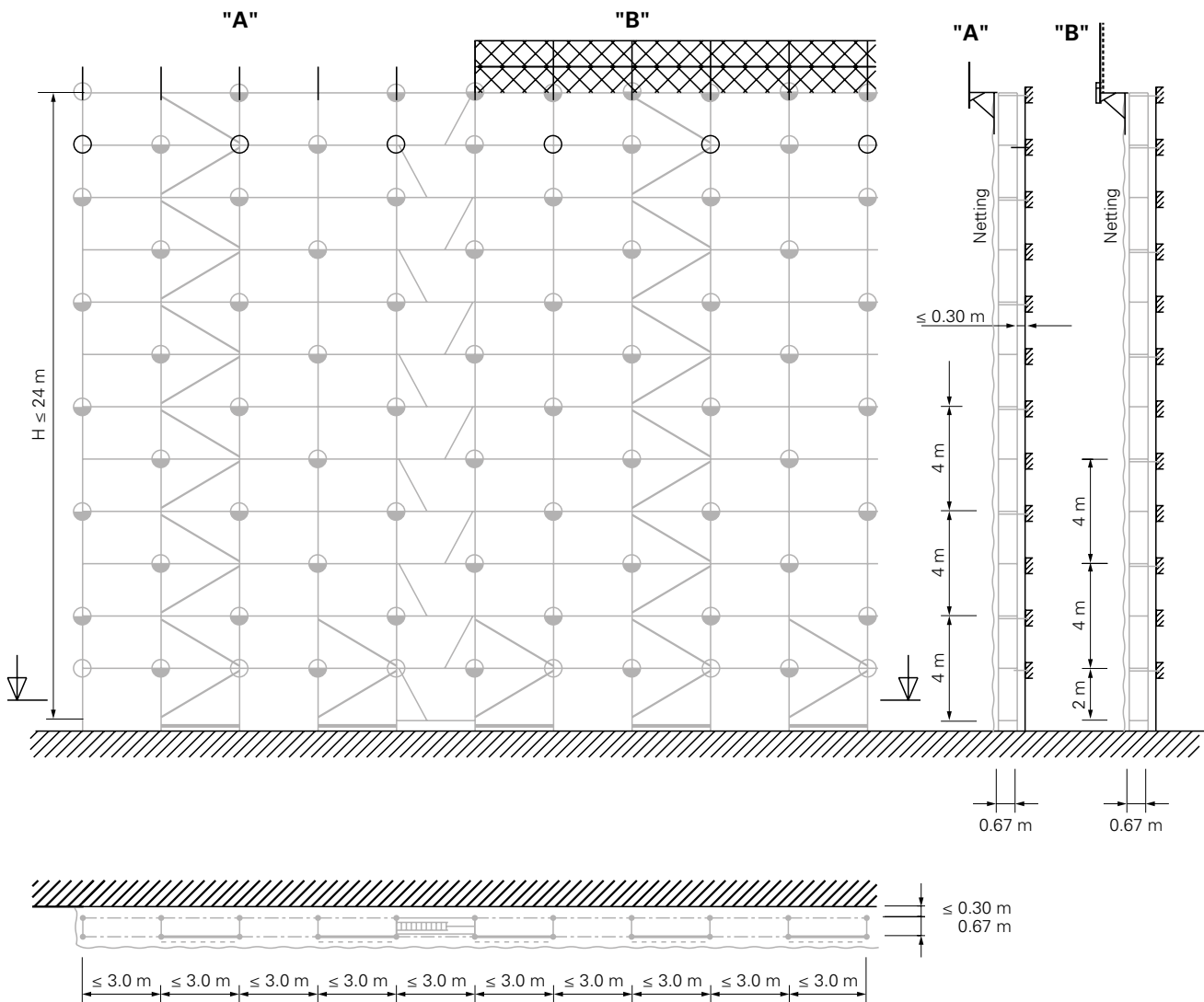

Note: lateral protection components not shown.

- ⊕ Single-standard wall tie
- ⊕ Wall tie

F4 Tie pattern

Standard variant ≤ 24 m

Variant 4.1/LC3

Protection roof execution

Take the following points into account in addition to the specified assembly guidelines for variant 4.1.



Tie pattern

- Anchor the protection roof position in each frame column with wall ties.

Bracing

- No additional bracing required.

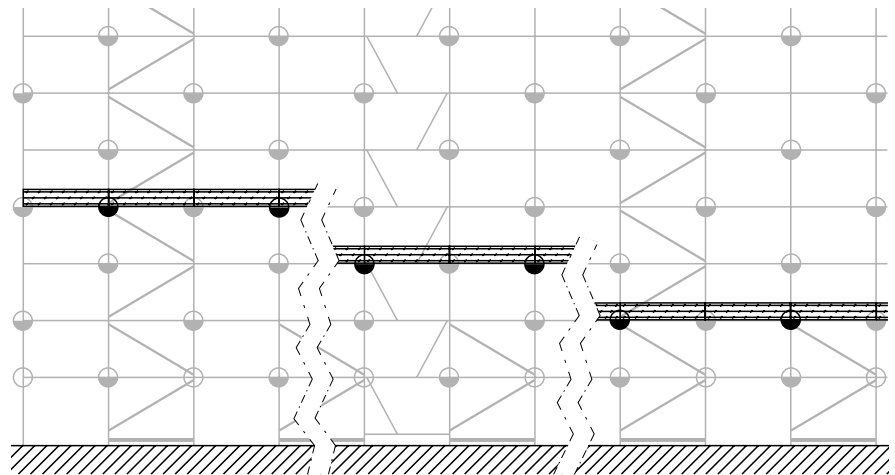

Easy 67

Note: lateral protection components not shown.

- ⊕ Single-standard wall tie
- ⊖ Wall tie

F4 Tie pattern

Standard variant ≤ 24 m

Variante 4.2/LC3

Standard configuration:
netting in front of open facade.

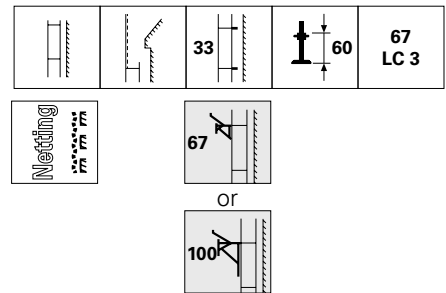

4 m offset tie pattern

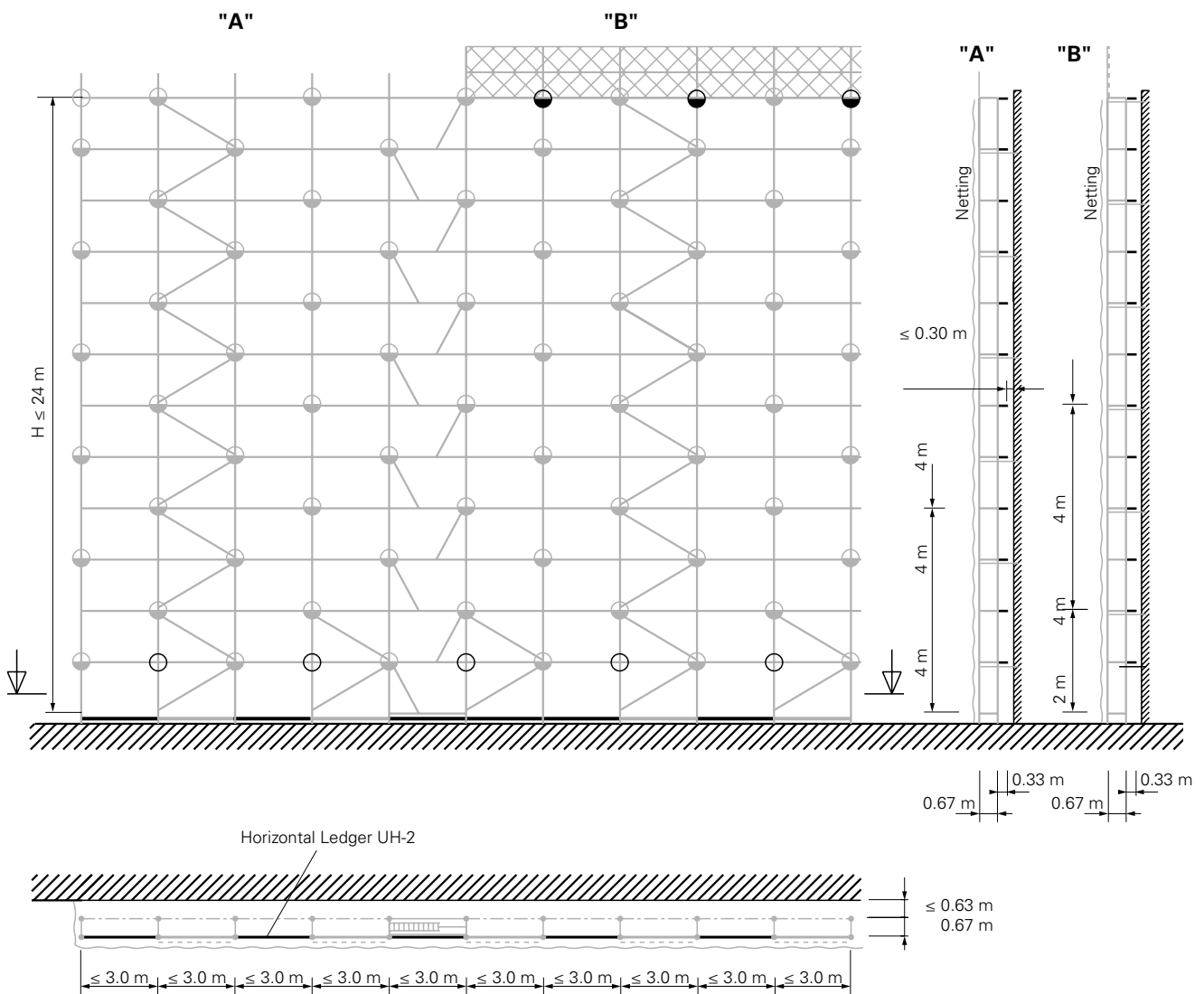

Note: lateral protection components not shown.

- ⊕ Single-standard wall tie
- ⊖ Wall tie

F4 Tie pattern

Standard variant ≤ 24 m

Variant 4.2/LC3

Protection roof execution

Take the following points into account in addition to the specified assembly guidelines for variant 4.2.

Tie pattern

- Anchor the protection roof position in each frame column with wall ties.

Bracing

- No additional bracing required.

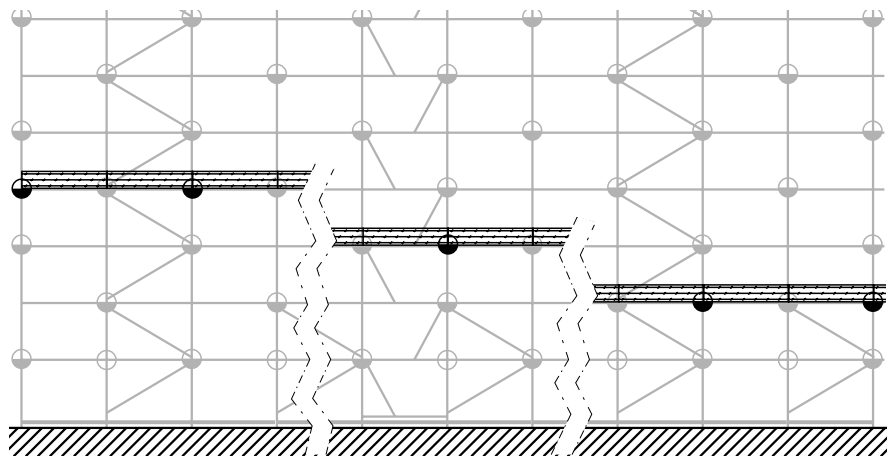

Easy 67

Note: lateral protection components not shown.

- ⊕ Single-standard wall tie
- ⊙ Wall tie

F4 Tie pattern



Standard variant ≤ 24 m

Variante 4.3/LC3

Standard configuration:
netting in front of open facade.

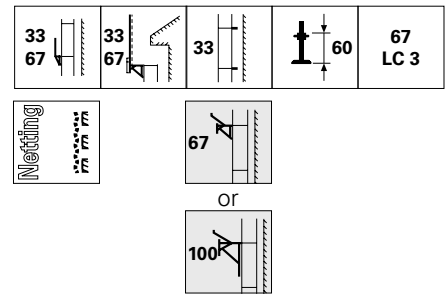

4 m offset tie pattern

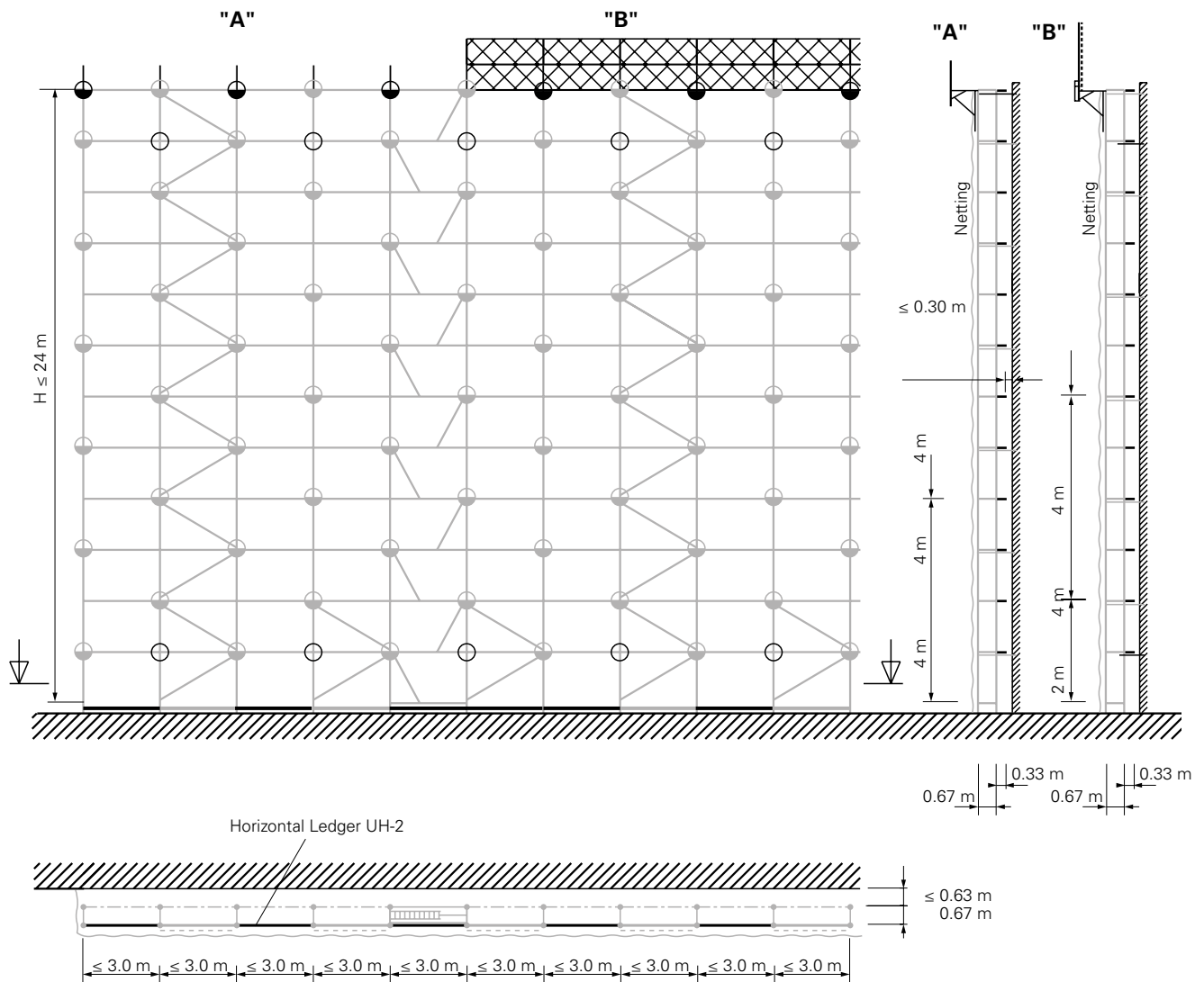

Note: lateral protection components not shown.

- ⊕ Single-standard wall tie
- Wall tie

Standard variant ≤ 24 m

Variant 4.3/LC3

Protection roof execution

Take the following points into account in addition to the specified assembly guidelines for variant 4.3.

Tie pattern

- Anchor the protection roof position in each frame column with wall ties.

Bracing

- No additional bracing required.

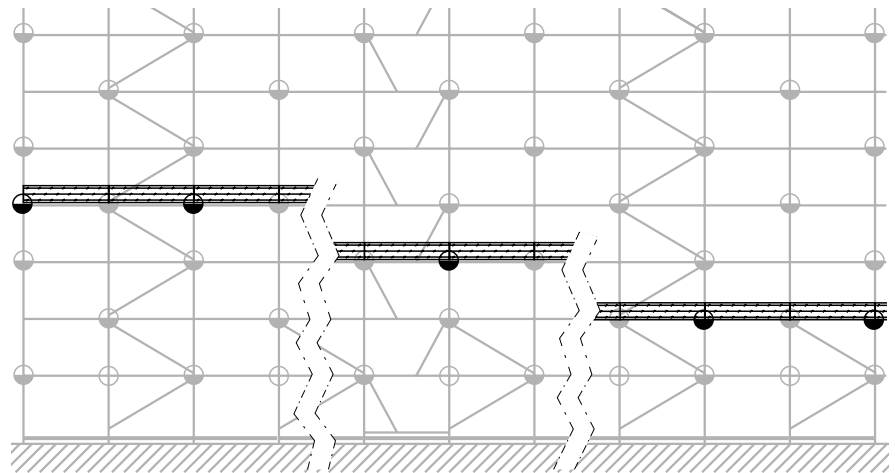

Easy 67

Note: lateral protection components not shown.

- ⊕ Single-standard wall tie
- ⊙ Wall tie

F4 Tie pattern

Standard variant ≤ 24 m

Variant 4.4/LC3

Standard configuration:
tarpaulin in front of closed facade.

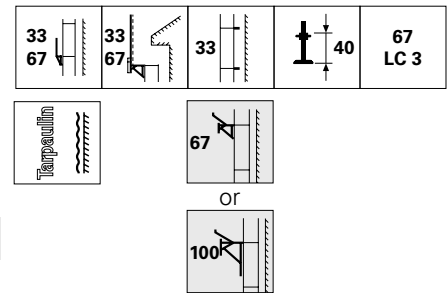

2 m tie pattern

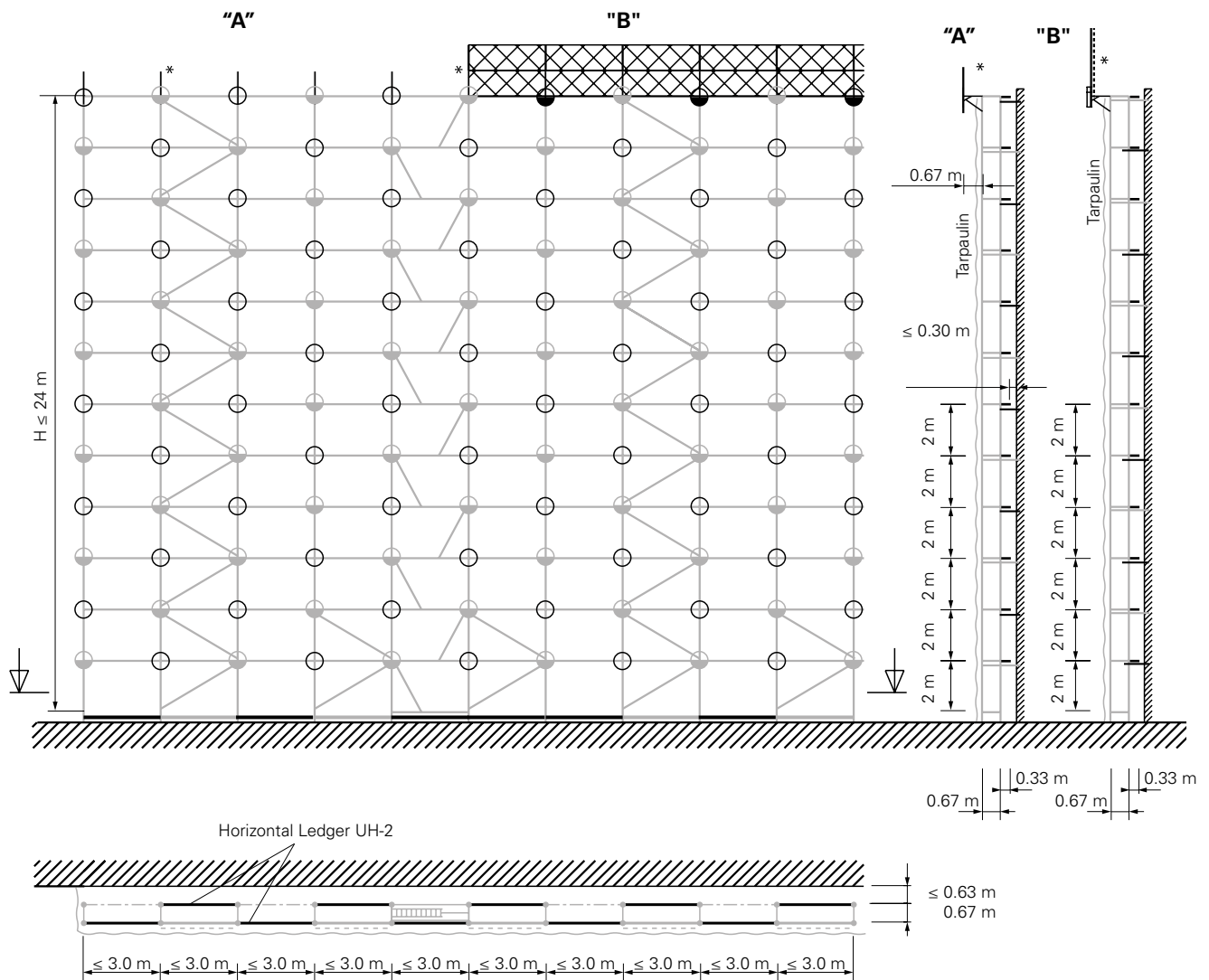

Note: lateral protection components not shown.

- ⊕ Single-standard wall tie
- ⊙ Wall tie
- * Secure the outer console brackets at the lower point of contact with the Guardrail Coupler EPR to prevent lifting.

F4 Tie pattern

Standard variant ≤ 24 m

Variant 4.4/LC3

Protection roof execution

Take the following points into account in addition to the specified assembly guidelines for variant 4.4.

Tie pattern

- Anchor the protection roof position in each frame column with wall ties.

Bracing

- No additional bracing required.

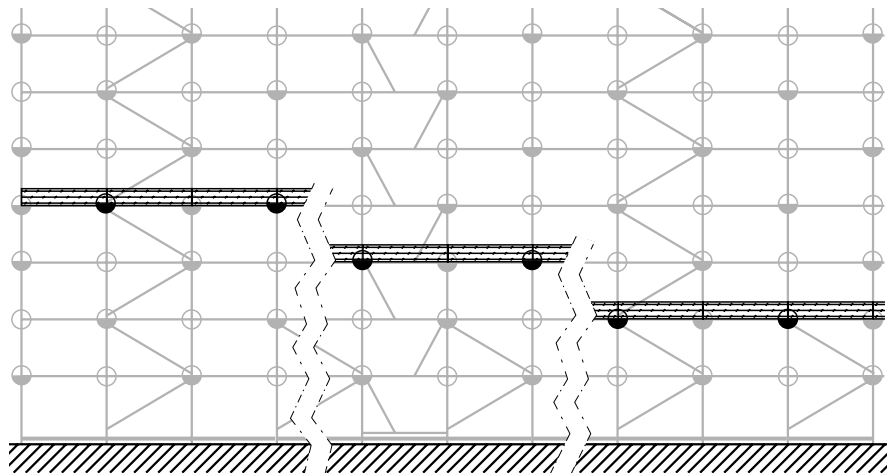

Easy 67

Note: lateral protection components not shown.

- ⊕ Single-standard wall tie
- ⊙ Wall tie

F5 Uplifting wind forces

For structures with roof inclination $\leq 20^\circ$, secure scaffolds to provide protection against lifting wind forces.

For this, secure all scaffold levels from the highest anchored level to the next anchored level by means of Locking Pins $\varnothing 48/57$ (19).

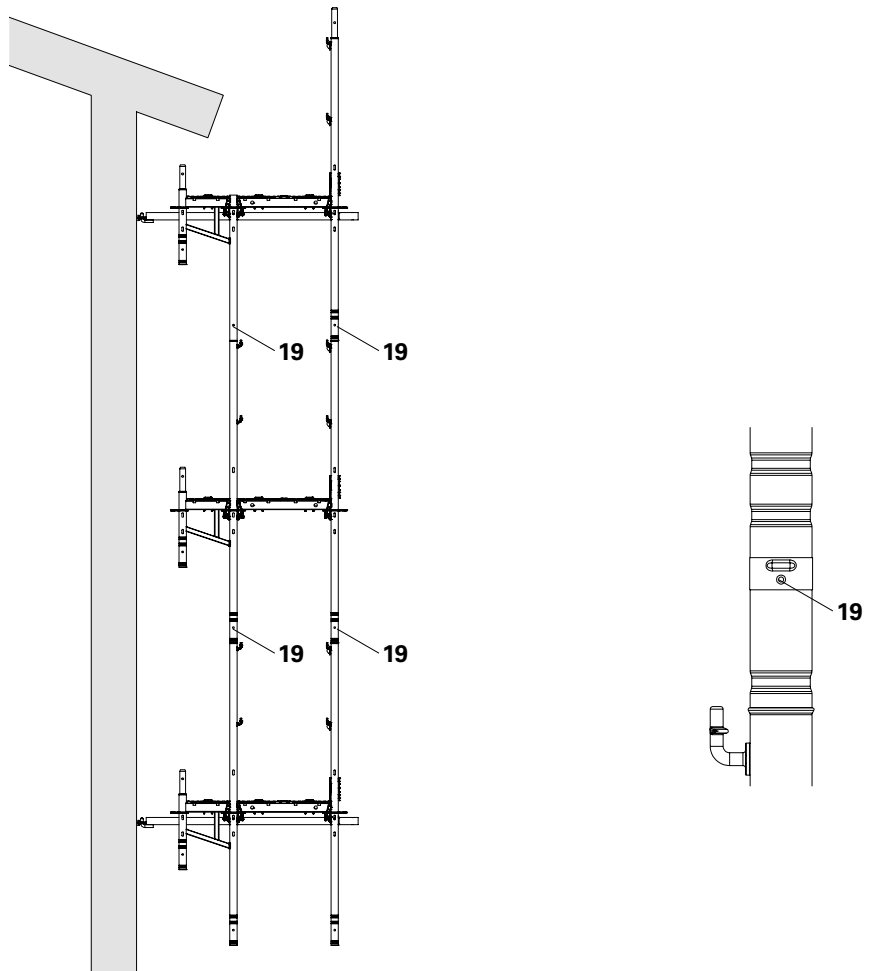

For structures with internal corners, secure scaffolds to provide protection against lifting wind forces.

- At the very least, secure the frame columns in the building corner, as well as the next frame column in each case.
- Secure all scaffold levels from the highest anchored level to the next anchored level by means of Locking Pins $\varnothing 48/57$ (19) or M10 x 70 bolts and nuts.

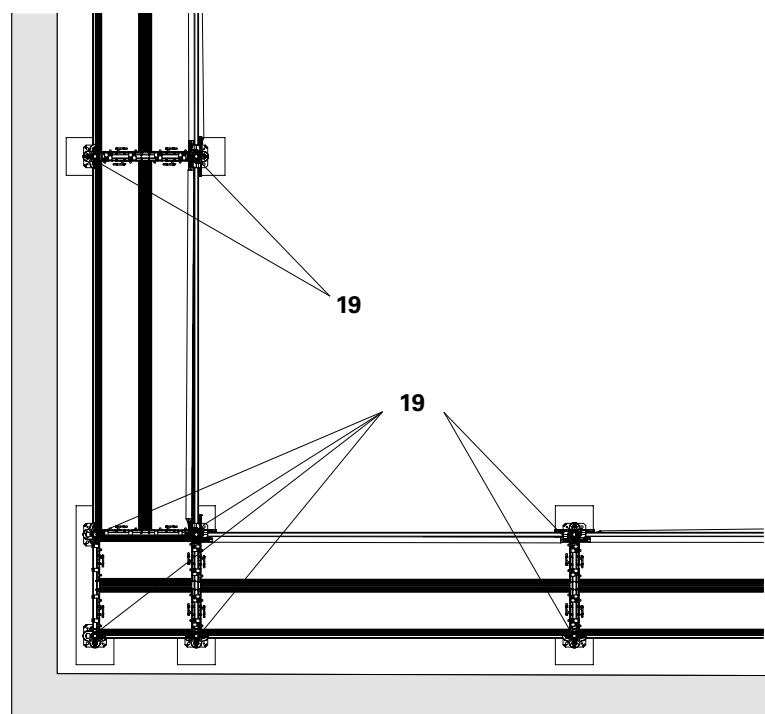

Note: lateral protection components not shown.

Anchoring with wall ties

PERI UP Easy 100, use in Load Class 4 (3.0 kN/ m ²)						
			Tie forces for (+ = tensile force/- = compressive force) **			
			Standard configuration for open facade		Standard configuration for closed facade	
Tie pattern	Cladding	Bay length [m]	Full-width wall tie			
			⌀ A _⊥ [kN]	⌀ A _∥ [kN]	⌀ A _⊥ [kN]	⌀ A _∥ [kN]
4.0 m	without	2.00	+/-1.7	2.7*	+/-0.6	2.7
		2.50	+/-1.9	2.7*	+/-0.6	2.7
		3.00	+/-2.2	2.7*	+/-0.7	2.7
	with netting	2.00	not possible		+/-1.3	2.1
		2.50	not possible		+/-1.6	2.1
		3.00	not possible		+/-1.9	2.1

Anchoring with triangulated ties or single-standard wall ties

PERI UP Easy 100, use in Load Class 4 (3.0 kN/ m ²)								
			Tie forces for (+ = tensile force/- = compressive force)					
			Standard configuration for open facade			Standard configuration for closed facade		
Tie pattern	Cladding	Bay length [m]	Single-standard wall tie	Triangulated tie (per anchoring point)		Single-standard wall tie	Triangulated tie (per anchoring point)	
			⌀ A _⊥ [kN]	+ A _⊥ [kN]	+ A _∥ [kN]	⌀ A _⊥ [kN]	+ A _⊥ [kN]	+ A _∥ [kN]
4.0 m	without	2.00	+/-1.2	+/-3.6	3.6	+/-0.4	+/-3.8	3.8
		2.50	+/-1.4	+/-3.7	3.7	+/-0.5	+/-3.8	3.8
		3.00	+/-1.6	+/-3.8	3.8	+/-0.5	+/-3.8	3.8
	with netting	2.00	not possible			+/-1.0	+/-3.0	3.0
		2.50	not possible			+/-1.3	+/-3.0	3.0
		3.00	not possible			+/-1.5	+/-3.0	3.0

open facade vs. closed facade depends on ratio of gross visible area of the facade A_g to net visible area of the facade with openings deducted A_n :
 $A_n/A_g = 1.0$: closed facade
 $A_n/A_g = 0.4 \leq x < 1.0$: open facade

** For protection panels, use whichever of the "open" and "closed" facade standard configurations is the worse.

* If there are only two continuous scaffold ties per five bays (variant 1), multiply the table value by 1.5.

Basic scaffold - Load Class 4

PERI UP Easy 100, use in Load Class 4 (3.0 kN/ m ²)					
	Equipment	Bay length [m]	Structure height		
			24 m	16 m	8 m
	Inner leg				
			F_i [kN]	F_i [kN]	F_i [kN]
	without internal console brackets	2.5	10.9	9.6	8.2
		3.0	12.7	11.3	9.7
	with Internal Console Bracket UCS 33	2.5	16.8	14.7	12.6
with Internal Console Bracket ECM 33	3.0	19.7	17.4	15.0	
	Outer leg				
			F_a [kN]	F_a [kN]	F_a [kN]
	without external console bracket	2.5	14.0	11.9	9.9
		3.0	16.4	14.1	11.8
			additional to F_a [kN]		
	with external console bracket ECM 33	2.5		1.9	
		3.0		2.3	
	Protection panel (in addition to console bracket or frame)	2.5		0.3	
		3.0		0.3	
	Protection roof on console bracket ECM 67 (incl. console bracket ECM 67)	2.5		0.8	
		3.0		1.0	
	Protection roof on console bracket ECM 100 (incl. console bracket ECM 100)	2.5		1.0	
3.0			1.2		

Easy 100

Basic scaffold - Load Class 3

PERI UP Easy 100, use in Load Class 3 (2.0 kN/ m²)

	Equipment	Bay length [m]	Structure height		
			24 m	16 m	8 m
	Inner leg				
			F_i [kN]	F_i [kN]	F_i [kN]
	without internal console brackets	2.5	9.0	7.7	6.3
		3.0	10.5	9.0	7.5
	with Internal Console Bracket UCS 33	2.5	13.7	11.6	9.5
	with Internal Console Bracket ECM 33	3.0	15.9	13.6	11.2
	Outer leg				
			F_a [kN]	F_a [kN]	F_a [kN]
	without external Console Bracket	2.5	12.1	10.1	8.0
		3.0	14.1	11.8	9.5
			additional to F_a [kN]		
	with external Console Bracket ECM 33	2.5	1.9		
		3.0	2.3		
	Protection panel (in addition to Console Bracket or frame)	2.5	0.3		
		3.0	0.3		
	Protection roof on Console Bracket ECM 67 (incl. Console Bracket ECM 67)	2.5	0.8		
		3.0	0.9		
	Protection roof on Console Bracket ECM 100 (incl. Console Bracket ECM 100)	2.5	1.0		
3.0		1.2			

Pavement gantries/bridgings

PERI UP Easy 100, use in load class 4 (3.0 kN/m²)

Pavement gantry

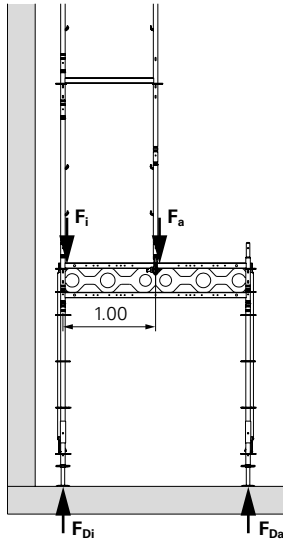

F_{Da}
[kN]

F_{Di}
[kN]

0.6 × F_a

F_i + 0.6 × F_a

Bridgings

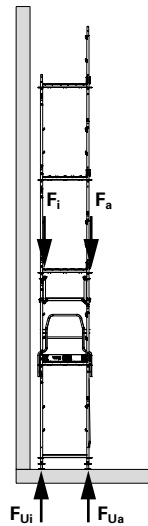
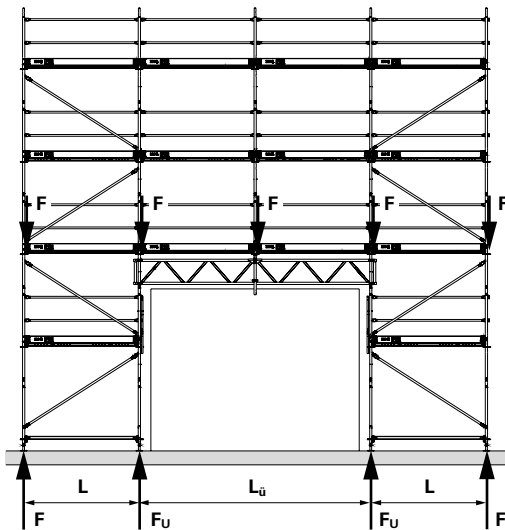

Bay length L
[m]

F_{Ua}
[kN]

F_{Ui}
[kN]

L_ü = 4.0 m

2.50

1.35 × F_a

1.35 × F_i

3.00

1.25 × F_a

1.25 × F_i

L_ü = 5.0 m

2.50

1.50 × F_a

1.50 × F_i

3.00

1.40 × F_a

1.40 × F_i

L_ü = 6.0 m

2.50

1.70 × F_a

1.70 × F_i

3.00

1.50 × F_a

1.50 × F_i

Select F_a and F_i for appropriate bay length L.

Overview of equipment variations

Standard variant ≤ 24 m, Load Class 4

PERI UP Easy 100: LC4 – 3.0 kN/m²: overview of equipment variations

LC4 – 3.00 kN/m ²		
	1a/b	2a/b
Page	232	234
alternatively possible with ▲ tie	233	235
Cladding	without	
Facade	open	
Internal Console Brackets ECM 33 or UCS 33 for $l \leq 2.50$ m	–	●
External Console Bracket ECM 33	–	–
External Console Bracket ECM 67	–	–
External Console Bracket ECM 100	–	–
Protection panel on outer leg	●	●
Protection roof on ECM 67	–	–
Protection roof on ECM 100	–	–
Bridging 5.0 m (2.5 + 2.5)	–	–
Bridging 6.0 m (3.0 + 3.0)	–	–
Pavement gantry	–	–

- Not permitted within this structural arrangement
- Possible within this structural arrangement – shown

G4 Tie pattern

Key

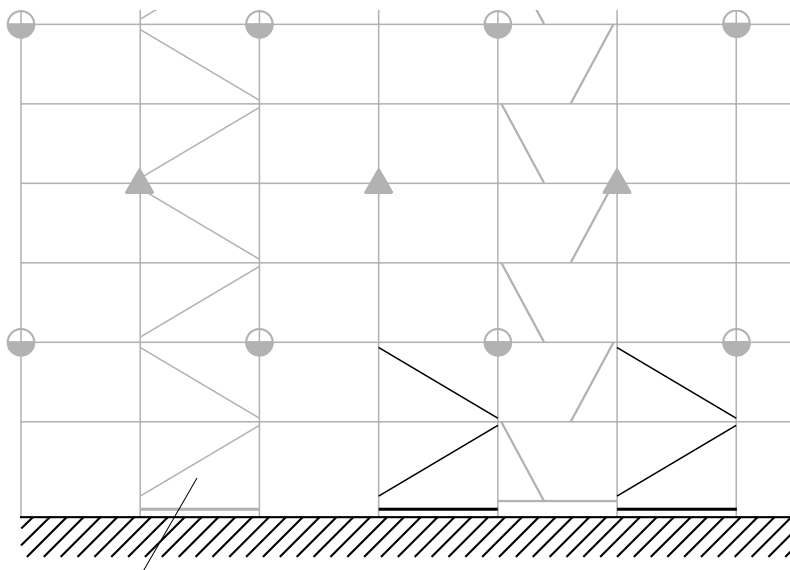
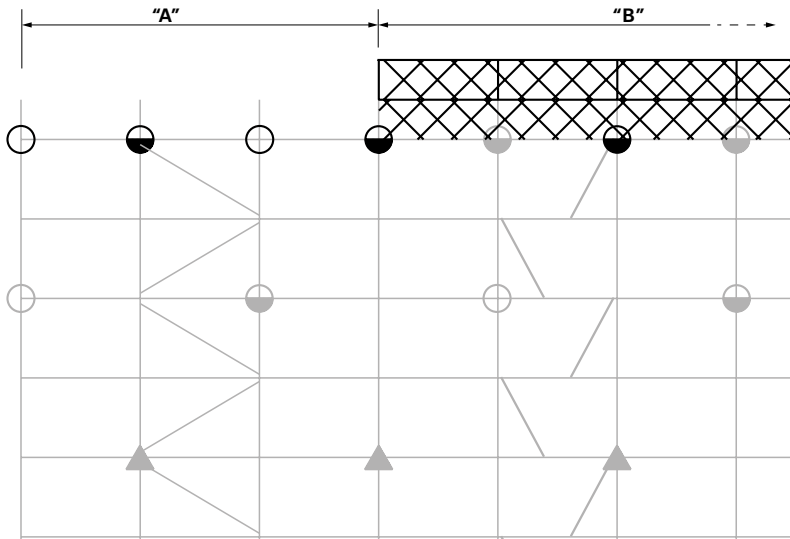

Braced bay

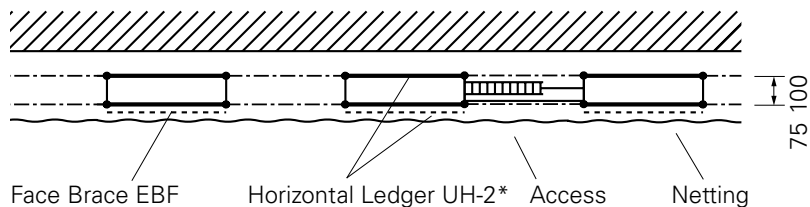

*Unless stated otherwise, horizontal ledgers are only required at the base level



All tie patterns illustrated are shown as a continuous scaffold with a left-hand edge post. There is no separation between the areas "A" and "B". At the right-hand edge of the illustration, the scaffold continues to run as intended.

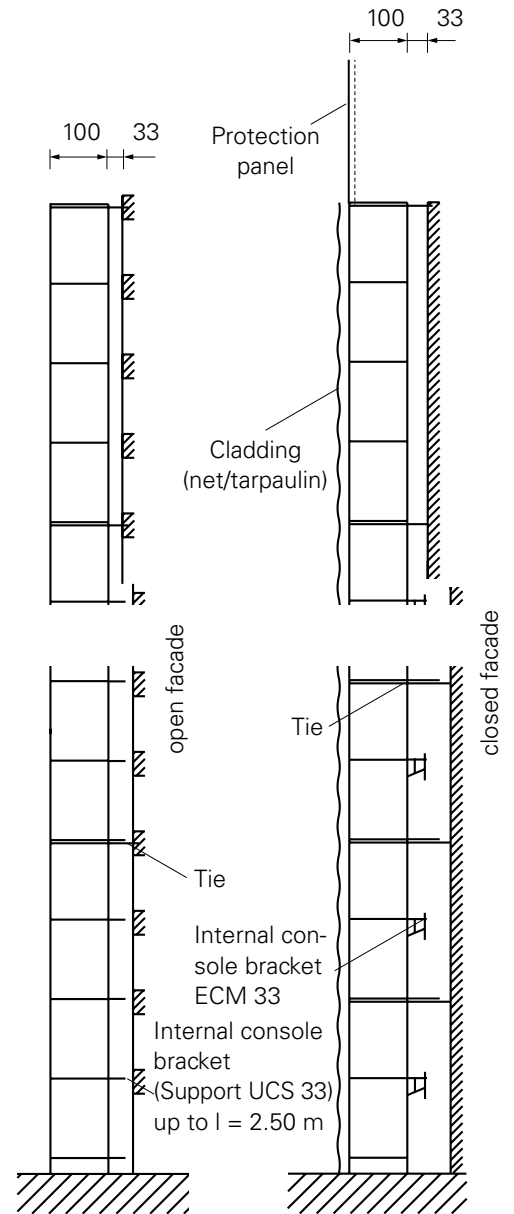

Tie types

- ⊕ Single-standard wall tie
- Wall tie
- ▲ Triangulated tie

Ties and bracing shown in grey are already included in the respective basic variant.

Modified or additional ties and bracing are shown in black.

Meanings of the pictograms

	<p>PERI UP Easy 100 Load class 4 (3.0 kN/m²)</p>	<p>Protection roof</p>		<p>on Console Bracket ECM 67</p>	<p>Bridging</p>		<p>6 m, with formwork girders</p>
	<p>Maximum spindle extension height h (incl. plate and nut)</p>			<p>on Console Bracket ECM 100</p>	<p>Scaffold with netting</p>		<p>in front of closed facade</p>
	<p>without console brackets</p>	<p>Protection panel</p>		<p>on Easy standard</p>		<p>in front of open facade (with <60% opening)</p>	
<p>Extension console brackets</p>				<p>on External Console Bracket ECM 33</p>	<p>Scaffold with tarpaulin</p>		<p>in front of closed facade</p>
	<p>External Console Bracket ECM 33</p>			<p>Internal Console Bracket ECM 33</p>	<p>Pavement gantry</p>		<p>in front of open facade (with <60% opening)</p>
	<p>Internal Console Brackets UCS 33 to = < 2.50 m</p>			<p>Pavement gantry</p>	<p>attachment parts not shown</p>	<p>Protection roof</p>	
	<p>Internal Console Bracket ECM 33</p>			<p>on Console Bracket ECM 67</p>			<p>on Console Bracket ECM 100</p>

Equipment variations:
Possible with additional local ties
cf. equipment variation tables

G4 Tie pattern

Graphical tie pattern Standard variant ≤ 24 m

Basic variant 1a/LC4

Standard configuration:
unclad scaffold in front of open or closed facade

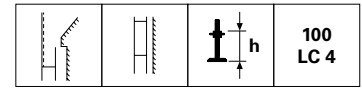

4 m tie pattern

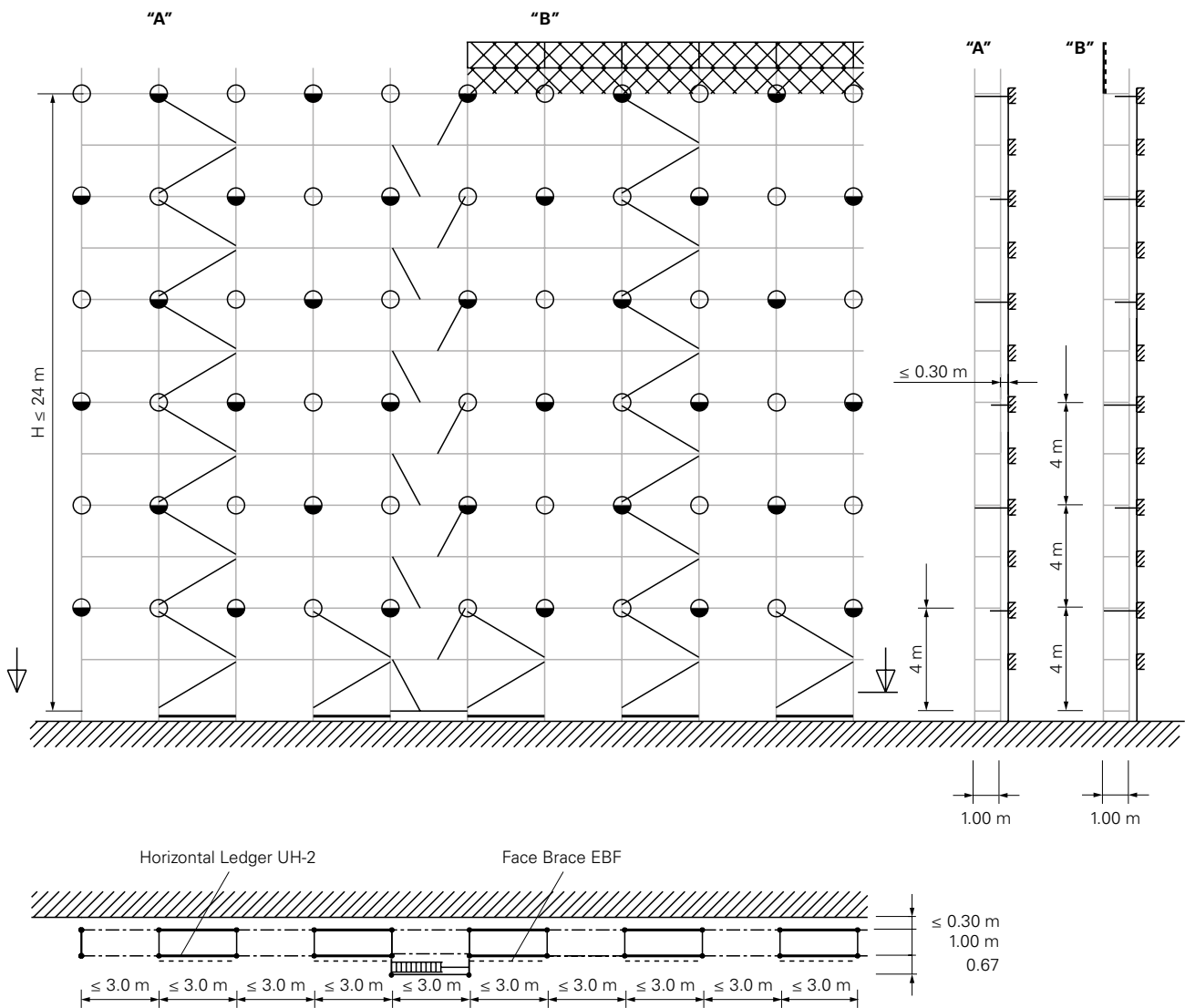

Note: lateral protection components not shown.

- ⊕ Single-standard wall tie
- ⊙ Wall tie

G4 Tie pattern

Standard variant ≤ 24 m

Basic variant 1b/LC4

Standard configuration:
unclad scaffold in front of open or closed facade

			100 LC 4
--	--	--	-------------

4 m tie pattern

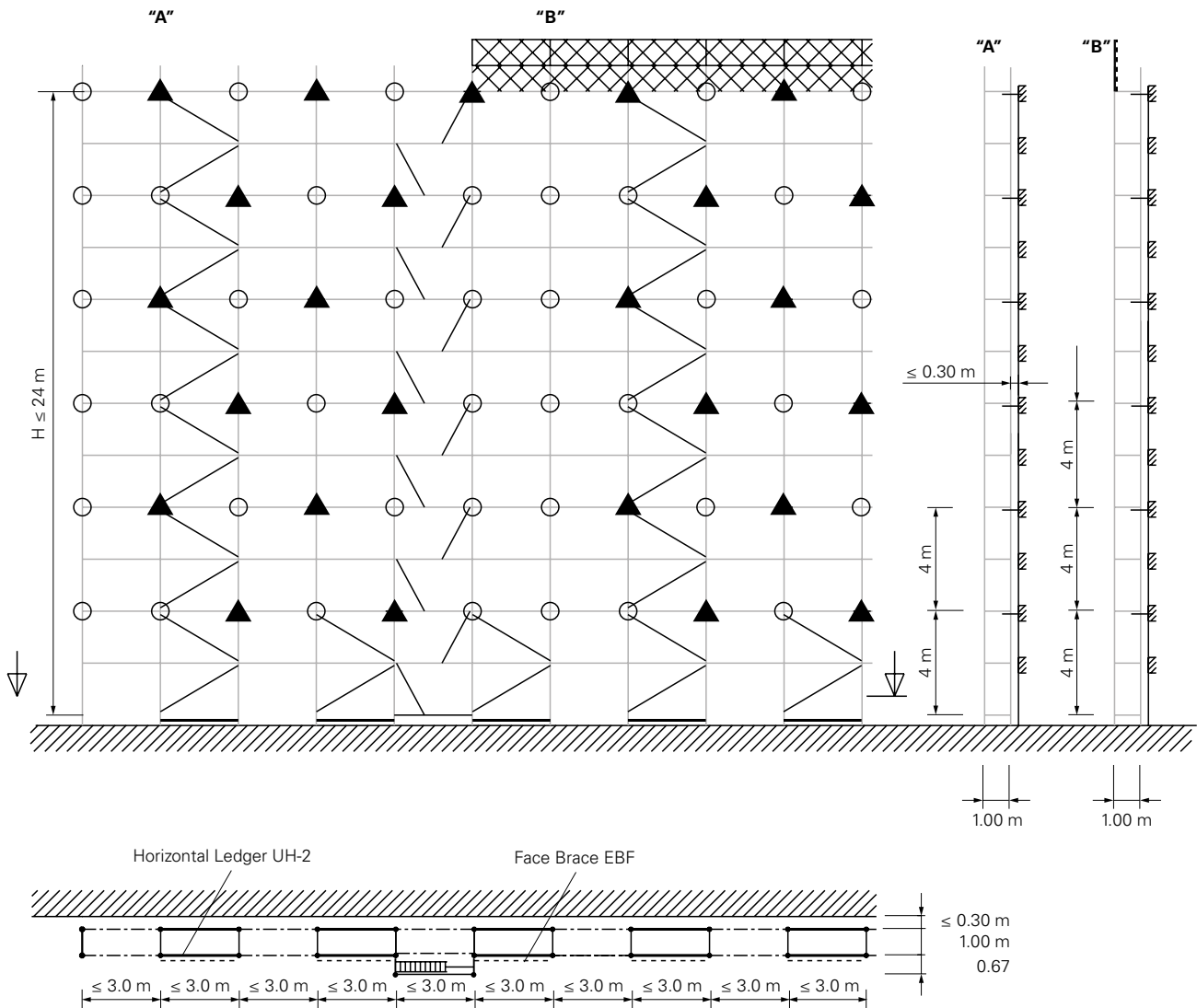

Note: lateral protection components not shown.

- ⊕ Single-standard wall tie
- ▲ Triangulated tie

Easy 100

G4 Tie pattern

Standard variant ≤ 24 m

Basic variant 2a/LC4

Standard configuration:
unclad scaffold in front of open or closed facade

	33		35	100 LC 4
--	----	--	----	-------------

4 m tie pattern

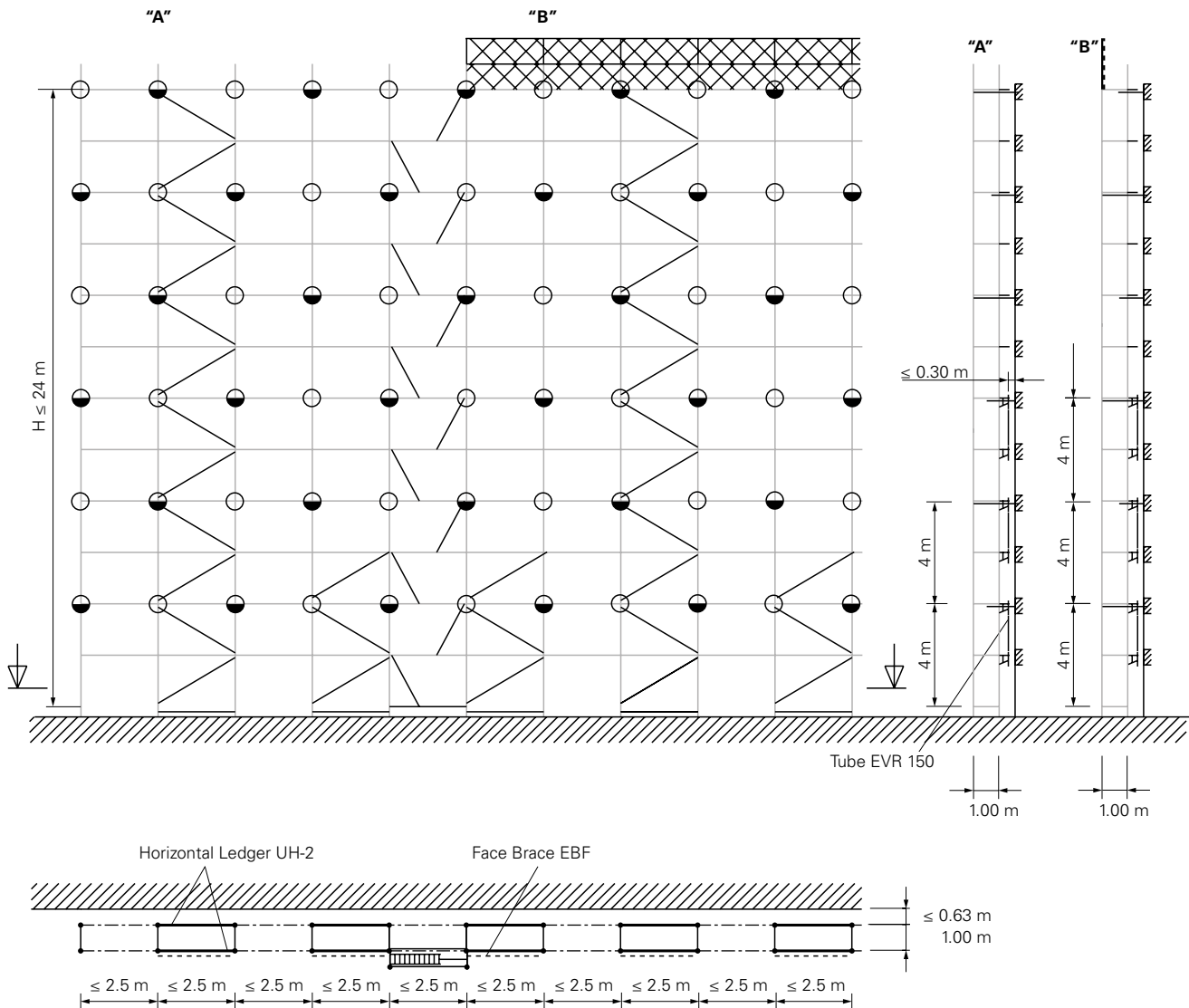

For details on the arrangement of the internal console brackets, see Section "Fitting internal console brackets onto the PERI UP Easy 100 (standard variant)" on page 106
Note: lateral protection components not shown.

- Single-standard wall tie
- Wall tie

G4 Tie pattern

Standard variant ≤ 24 m

Basic variant 2b/LC4

Standard configuration:
unclad scaffold in front of open or closed facade

	33		35	100 LC 4
--	----	--	----	-------------

4 m tie pattern

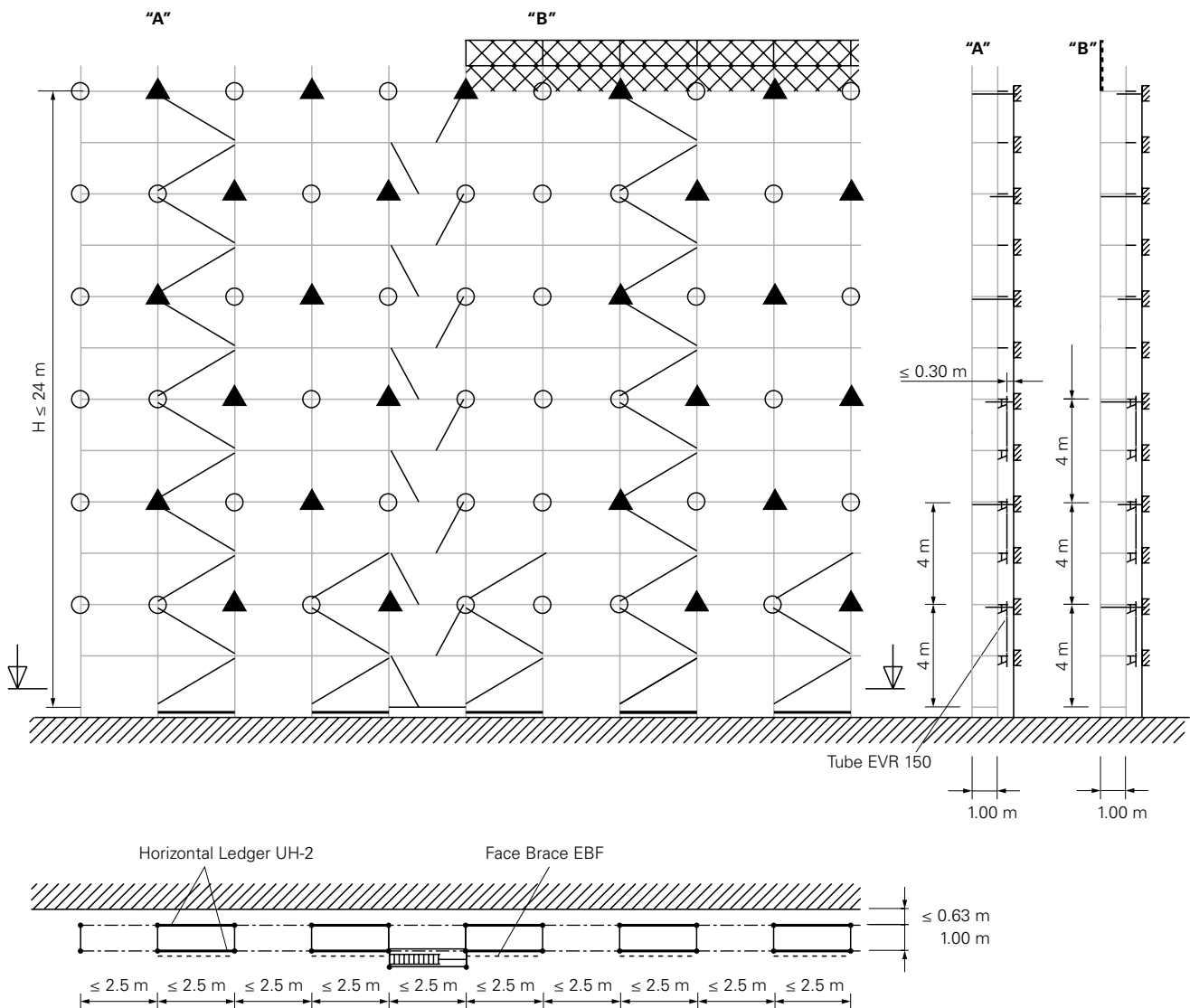

For details on the arrangement of the internal console brackets, see Section "Fitting internal console brackets onto the PERI UP Easy 100 (standard variant)" on page 106
Note: lateral protection components not shown.

- ⊕ Single-standard wall tie
- ▲ Triangulated tie

Easy 100

G5 Uplifting wind forces

For structures with roof inclination $\leq 20^\circ$, secure scaffolds to provide protection against lifting wind forces.

For this, secure all scaffold levels from the highest anchored level to the next anchored level by means of Locking Pins $\varnothing 48/57$ (19) or bolts and nuts.

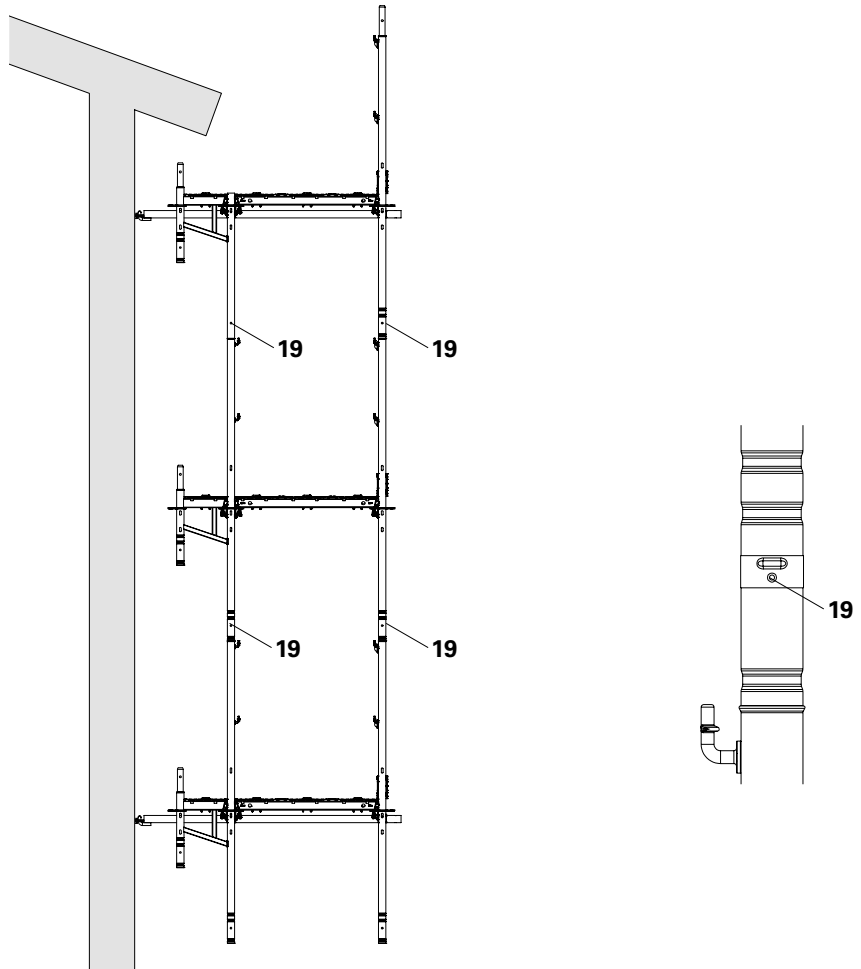

For structures with internal corners, secure scaffolds to provide protection against lifting wind forces.

- At the very least, secure the frame columns in the building corner, as well as the next frame column in each case.
- Secure all scaffold levels from the highest anchored level to the next anchored level by means of Locking Pins $\varnothing 48/57$ (19) or bolts and nuts.

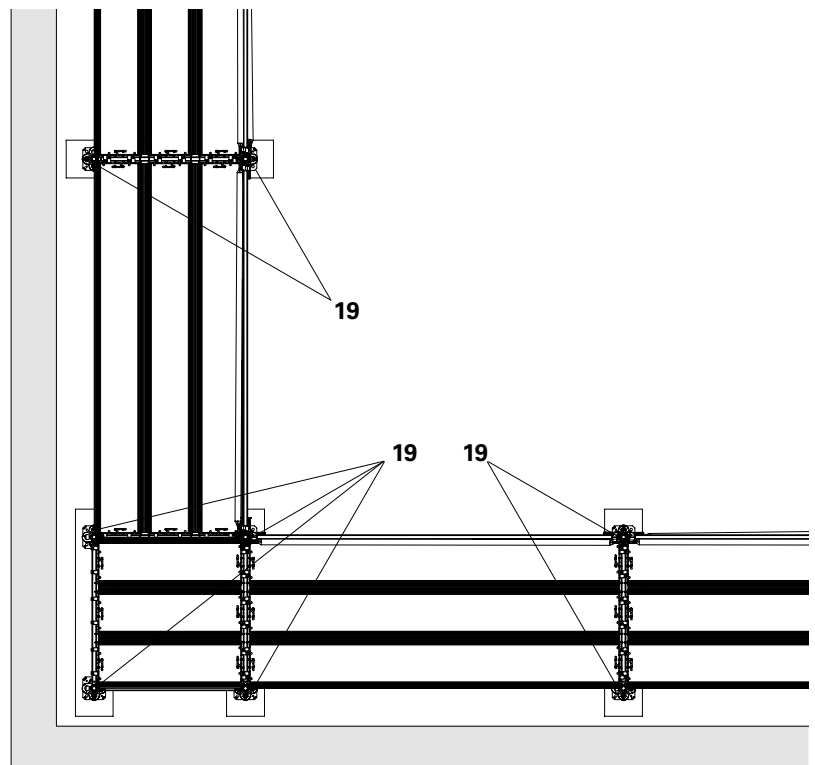

Note: lateral protection components not shown.

General

In addition to the standard configuration shown in these Instructions for Assembly and Use, a wide range of structural arrangements are possible.



The following structural arrangements are not covered by the standard configuration.

They are examples only and are not to be understood as assembly instructions in any way.

Installation instructions must be prepared for these structural arrangements by the contractor and the scaffolding team is to be briefed on the content!



Executions deviating from the standard configuration require separate static proof of stability.



Warning

In the following examples, assembly situations can arise whereby there is a risk of falling.

- ⇒ Use personal protective equipment to prevent falling from a height (PPE)!
- ⇒ Use the verified attachment points!

Scaffolding support

On structures that do not allow anchoring, scaffolding support can be attached to the scaffold.
Continuously install scaffolding support in line with basic scaffold assembly.

If required, the support bays with Horizontal Ledgers UHV-2 and decks can be used as ballast support, for example, if pressure support is not possible. Do not exceed the maximum permissible load!

For assembly of the scaffolding support, the following are also required:

- Easy Standard EVM 200,
- Horizontal Ledger UH-2,
- Ledger Brace UBL-2
- Horizontal Brace UBH Flex.

(Fig. H.01 – H.01b)



Alternatively, the Standard UVR-2 200 can be used.

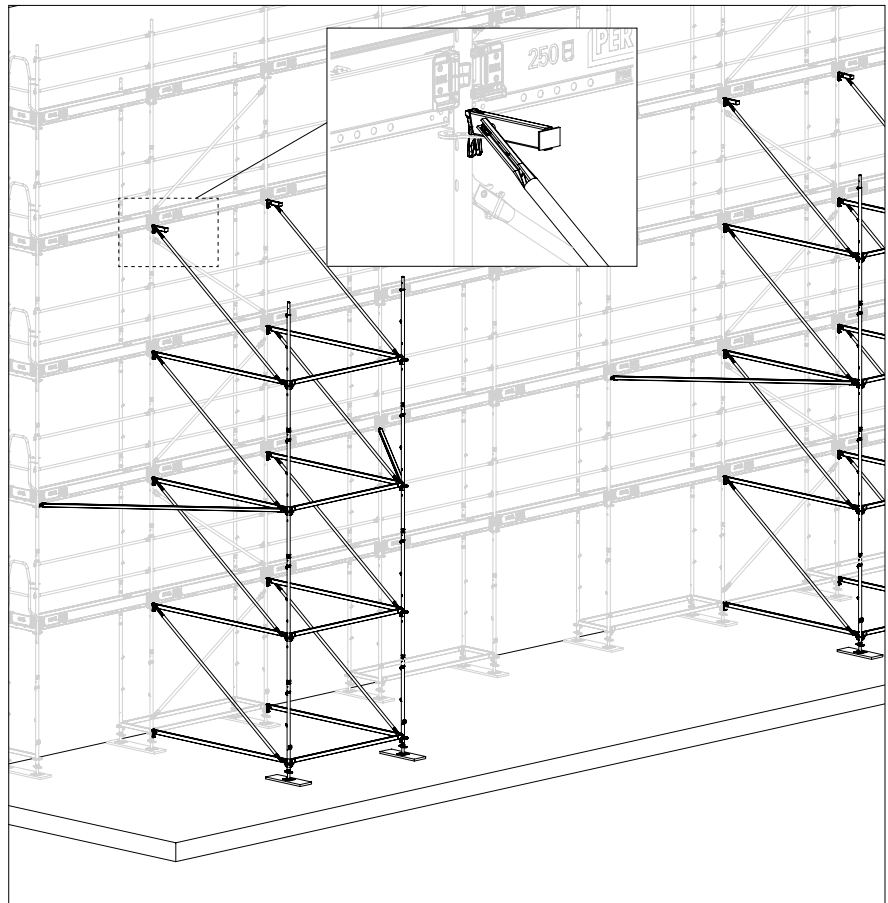

Fig. H.01

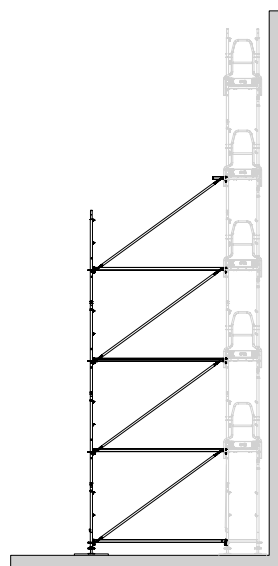

Fig. H.01a

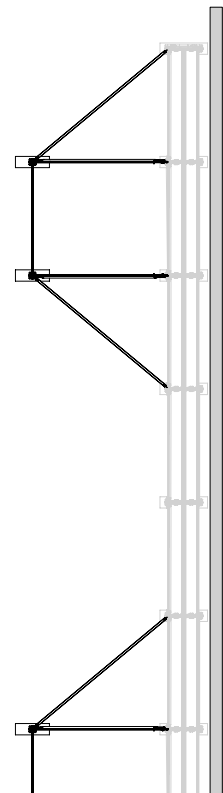

Fig. H.01b

Landing platform

Landing platforms can be installed to store materials.
Do not exceed the maximum permissible load!

- ① = tensile force
 - ② = compressive force
- (Fig. H.02 + H.03)

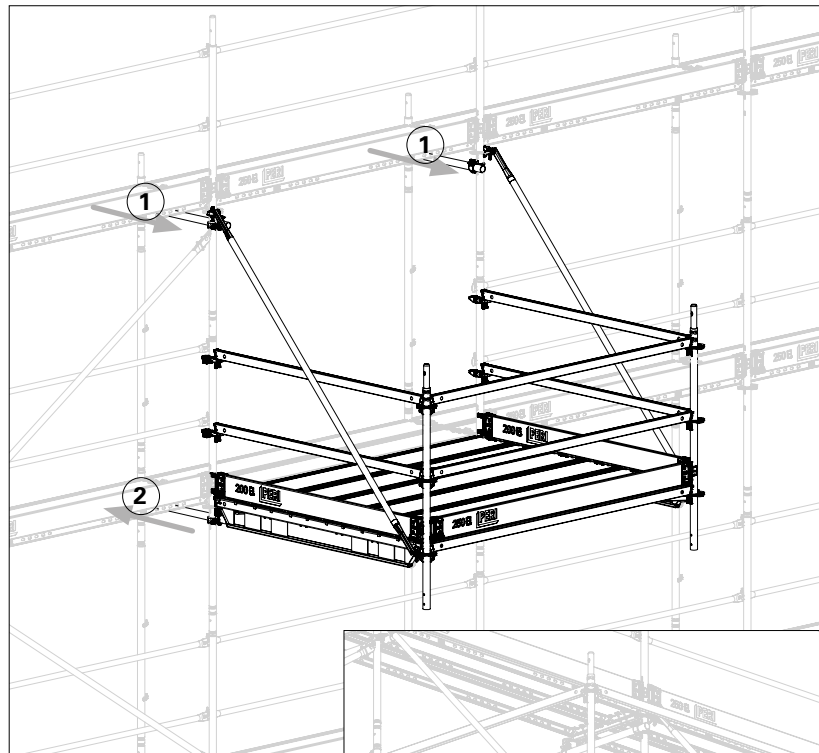

Fig. H.02

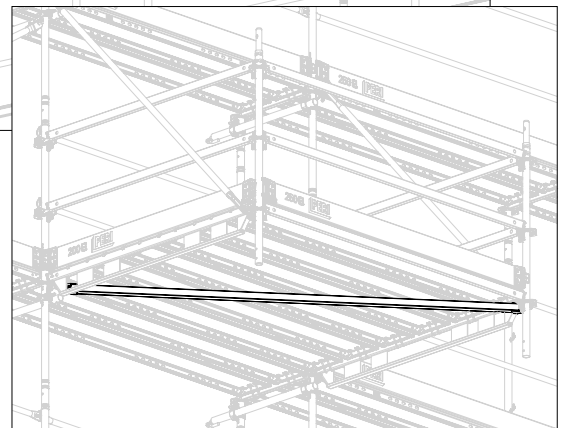
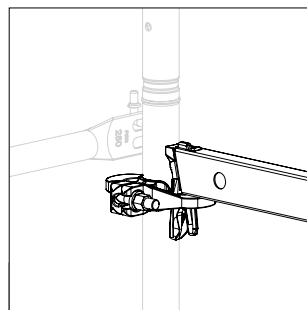

Fig. H.03



Variant:

Node braces for vertical bracing can also be installed, supported from the scaffold level immediately below.

- ① = tensile force
 - ② = compressive force
- (Fig. H.04)

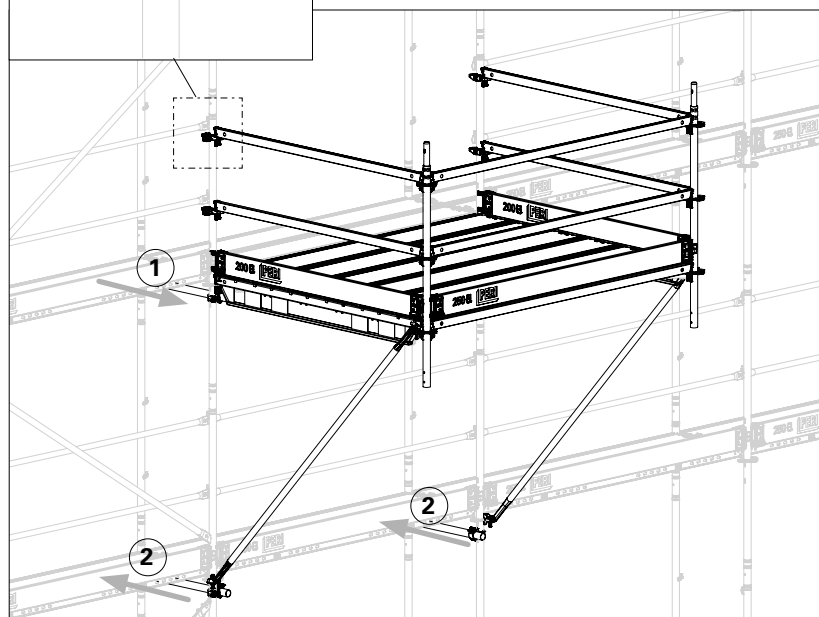

Fig. H.04

External access with Stair Tower EAS/UAS-2 and Standards UVR-2

If required, scaffold access can also be realised with Standards UVR-2 instead of using Easy Standards.

Horizontal Ledgers UH-2 are installed as lateral protection.

In terms of lateral protection, it is sufficient to simply wedge the horizontal ledgers into the rosette of the stair post.



In addition, the horizontal ledger can be installed on the Easy standard using a screw-on rosette. From a structural point of view, however, this is not necessary.

To assemble the scaffold access, the following are also required:

- Standard UVR-2 300,
- Standard UVR-2 200,
- Horizontal Ledger UH-2 75.

Depending on the situation and customer requirements

- a Safety Entry Gate UPS can be installed at the entrance to the staircase,
- and a Stair Guardrail UAG at any position on the inner side of the flight of stairs.

(Fig. H.05)

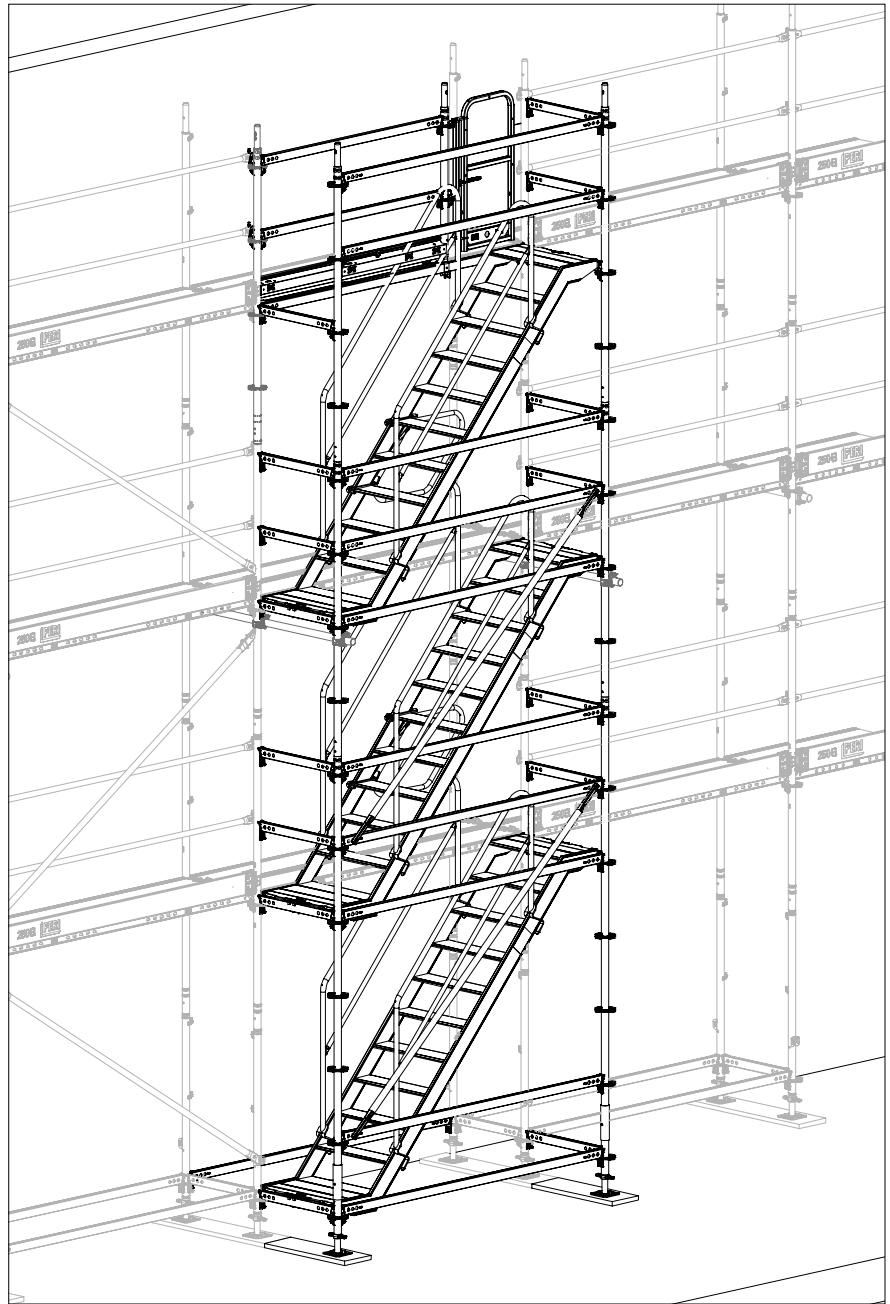

Fig. H.05

Adjusted roof protection

Outreach 33 cm,
Height 1.00 m.
(Fig. H.06 + H.06a)



Lateral protection components not shown.

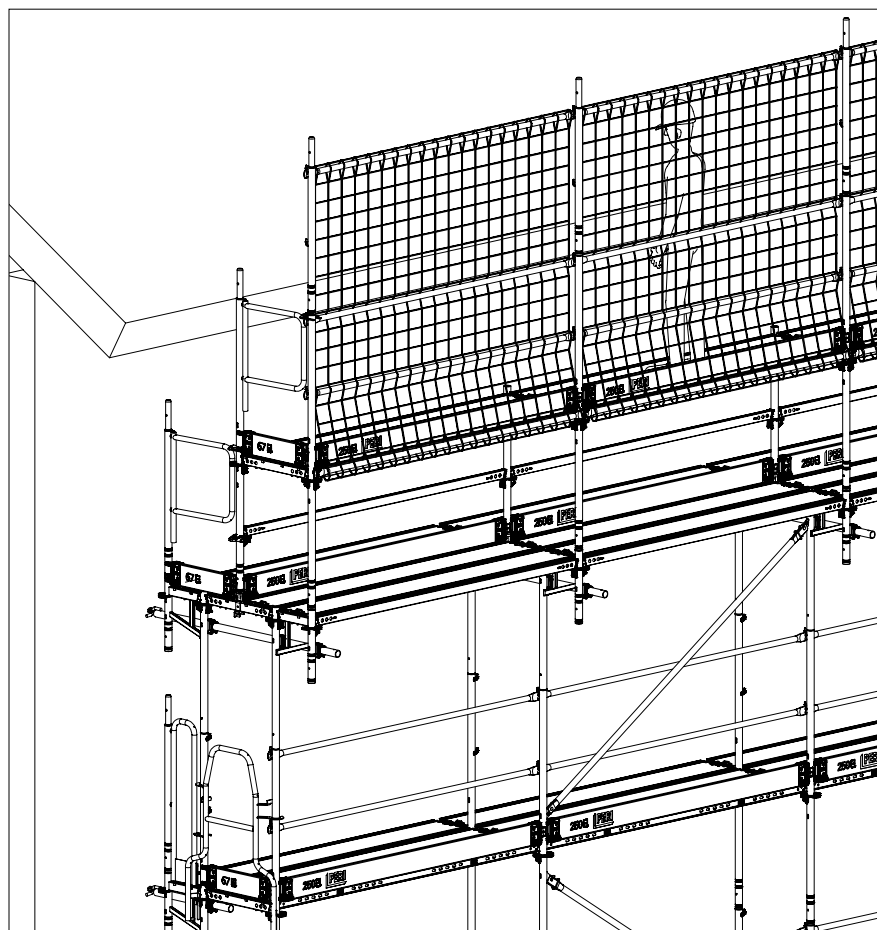

Fig. H.06

Section

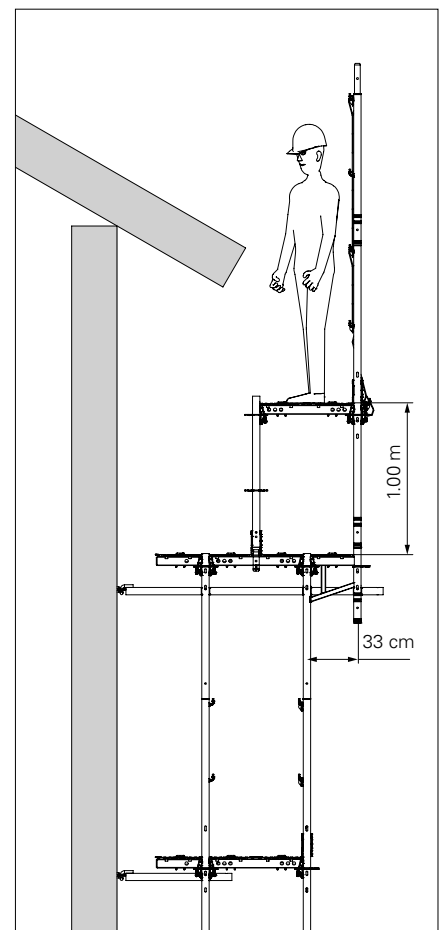

Fig. H.06a

Adjusted roof protection

Outreach 67 cm,
Height 1.00 m.
(Fig. H.07 + H.07a)



Lateral protection components not shown.

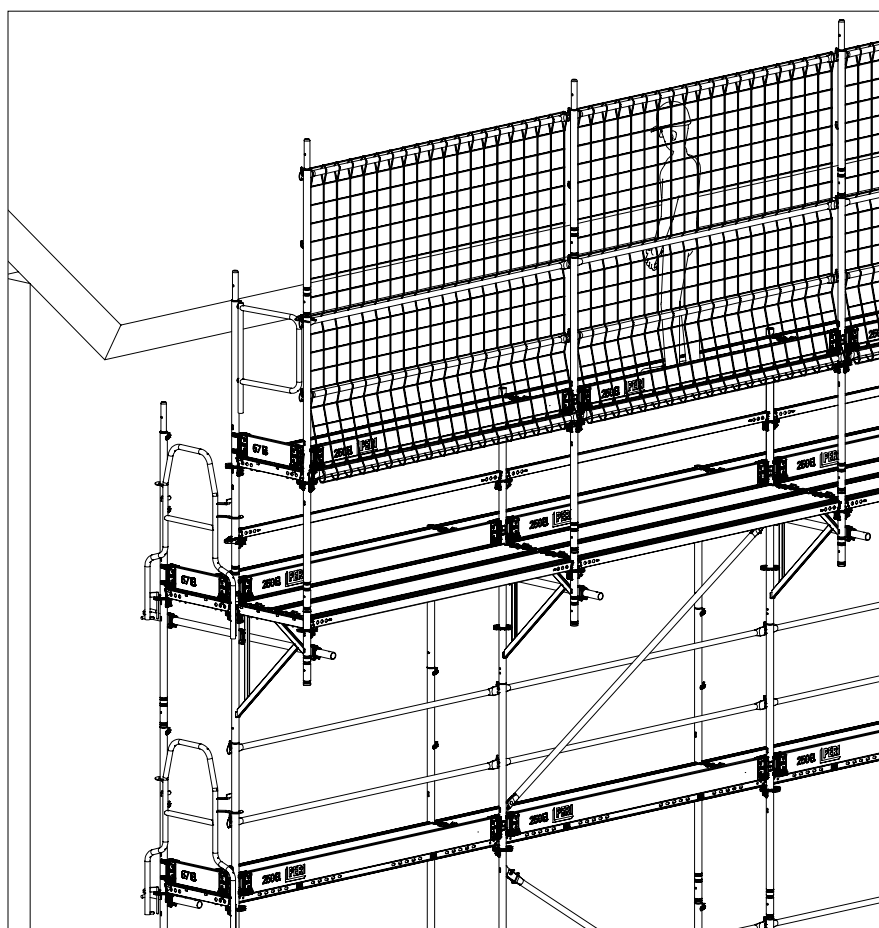

Fig. H.07

Section

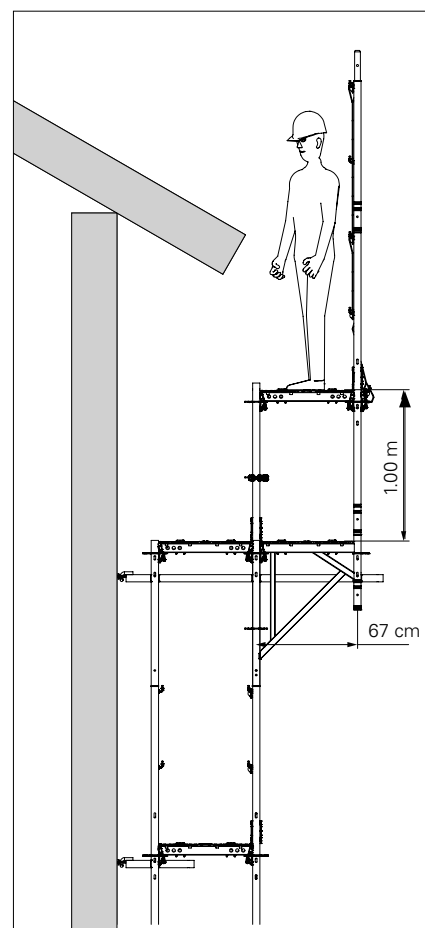

Fig. H.07a

Adjusted roof protection

Outreach 33 cm,
Height 1.50 m.
(Fig. H.08 + H.08a)



Lateral protection components not shown.

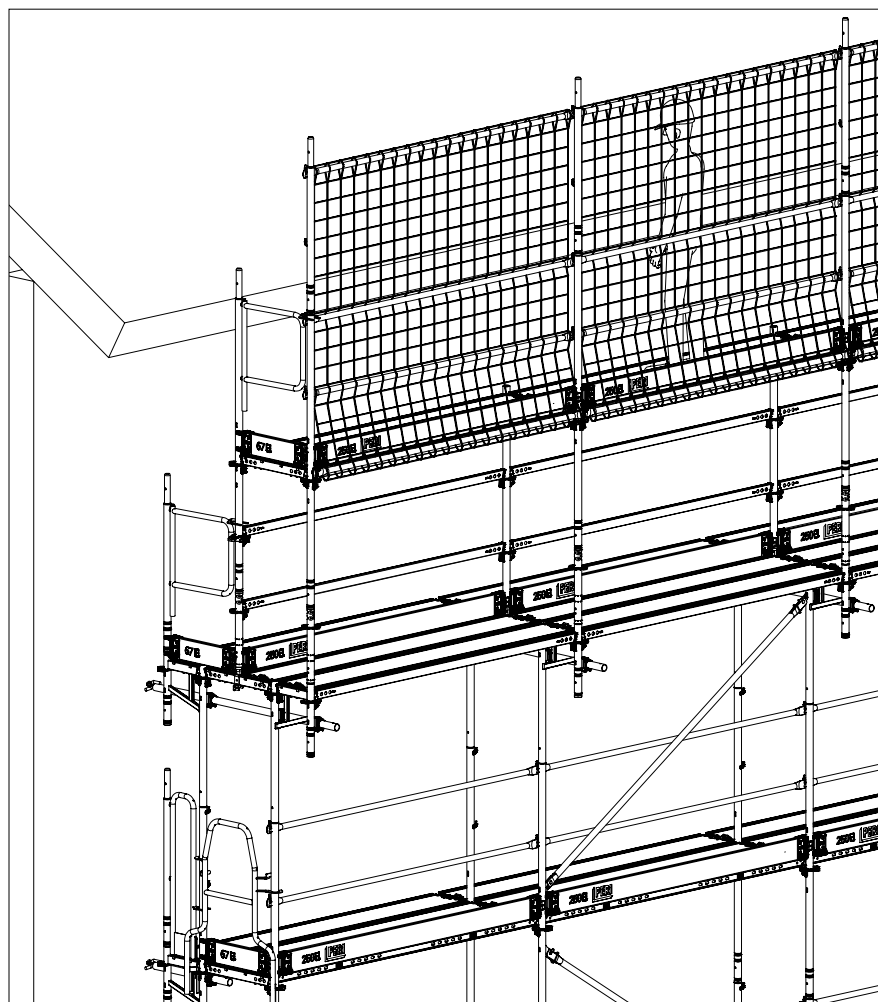

Fig. H.08

Section

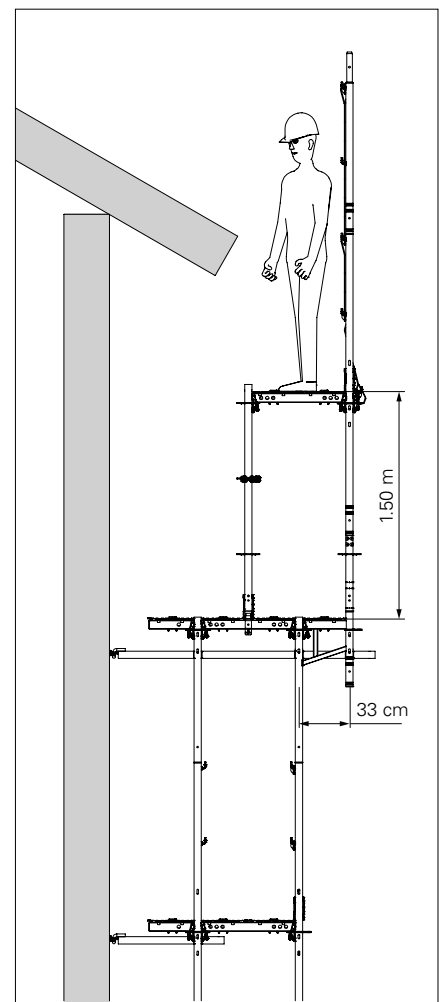

Fig. H.08a

Adjusted roof protection

Outreach 67 cm,
Height 1.50 m.
(Fig. H.09 + H.09a)



Lateral protection components not shown.

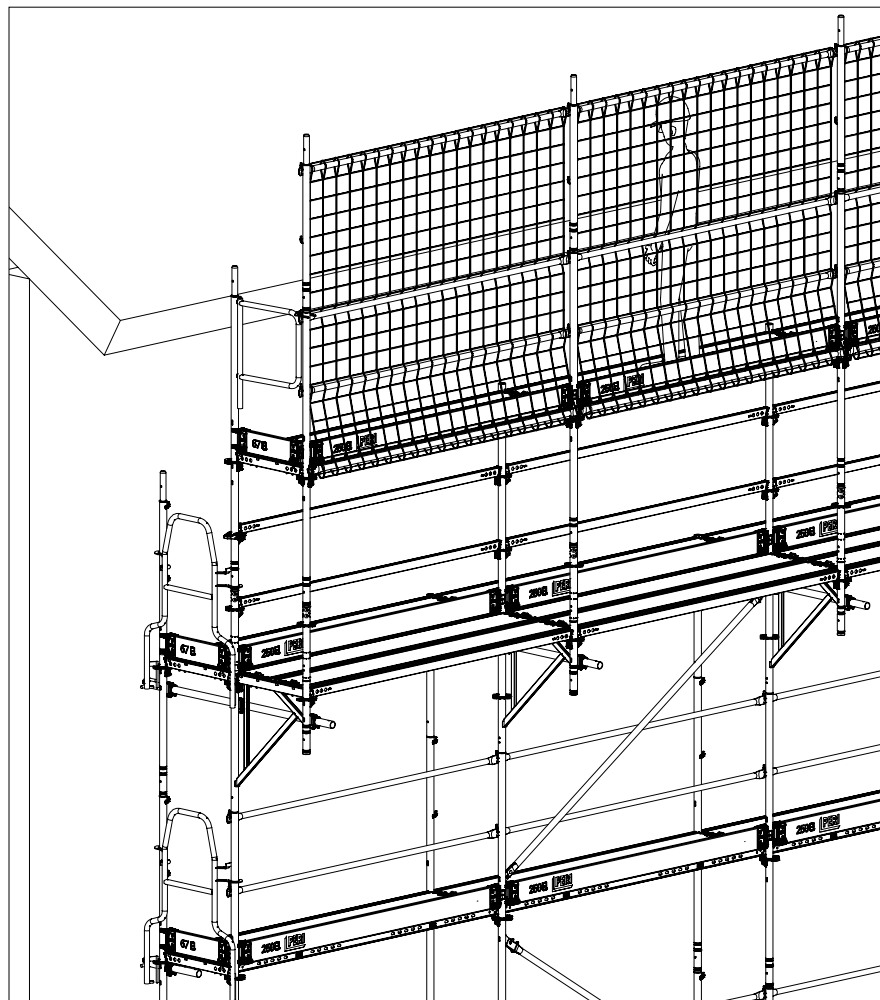

Fig. H.09

Section

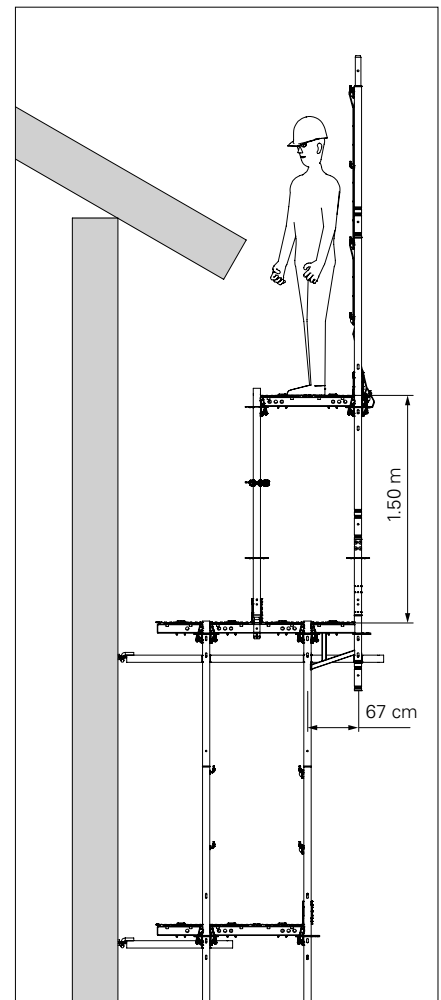

Fig. H.09a

Bridging with node braces

Bridging without formwork girders can be realised with four Node Braces UBK-2 (87), four Horizontal Ledgers UH-2 (94) and a base unit consisting of 2 x Easy Base Standard EVS 124 (23) and 1 x Horizontal Ledger UH-2 67 (98). On the base unit, further assembly of the scaffold takes place as described.

Up to a bridging width of 3 m, the bridging can be formed from the basic scaffold. Auxiliary scaffolding is also required.

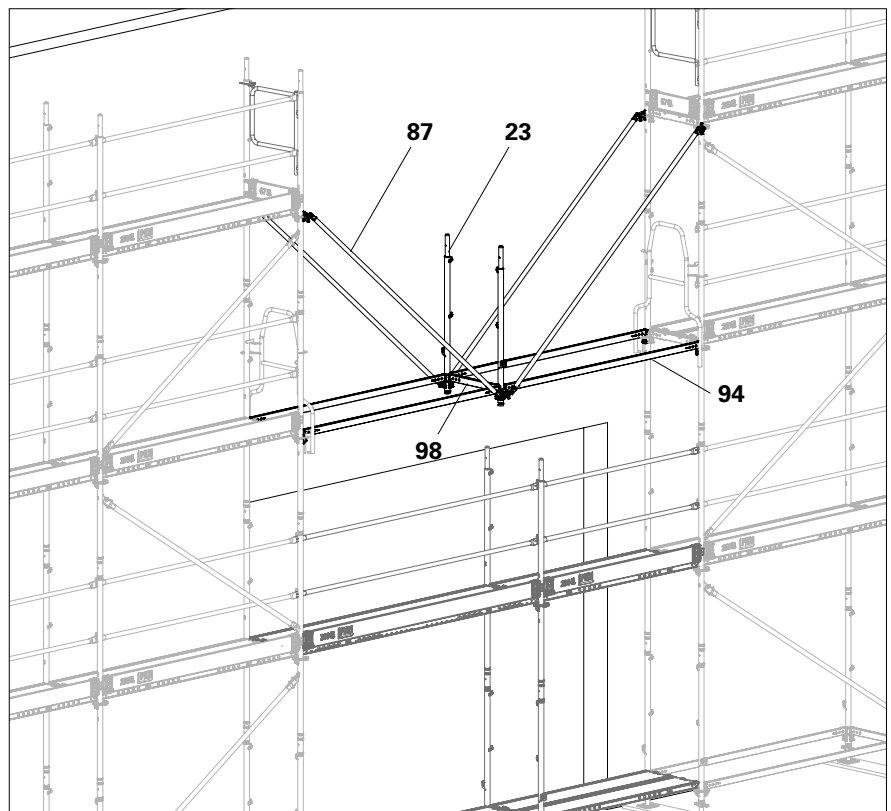

Fig. H.10

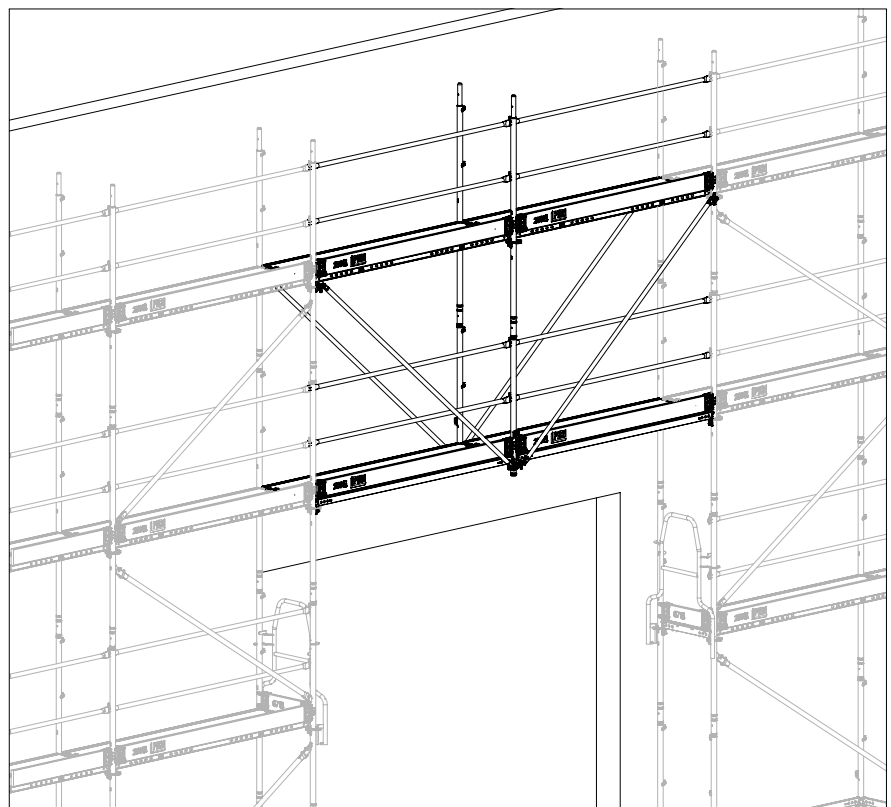

Fig. H.10a

Article no. Weight kg

116762 2.830

Base Spindle UJB 38-36/17

Note

With captive quick jack nut.

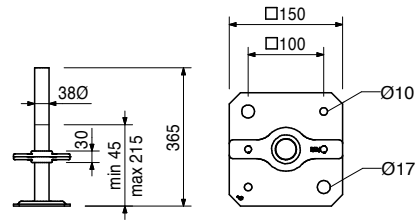
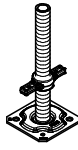

Accessories

100863 1.020

Spindle Locking UJS

100411 3.390

Base Spindle UJB 38-50/30

Note

With captive red quick jack nut.

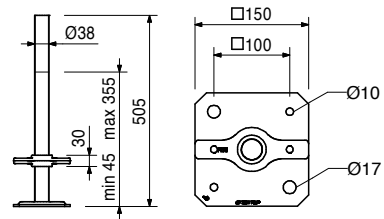

Accessories

100863 1.020

Spindle Locking UJS

100242 4.570

Base Spindle UJB 38-80/55

Note

With captive yellow quick jack nut.

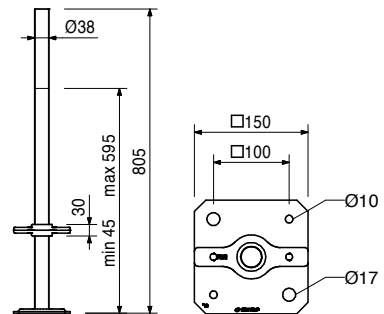
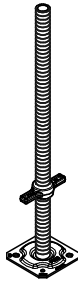

Accessories

100863 1.020

Spindle Locking UJS

Article no. Weight kg

100159	5.130
--------	-------

Pivoting Base Spindle UJS 38-80/50

Note

With captive yellow quick jack nut.

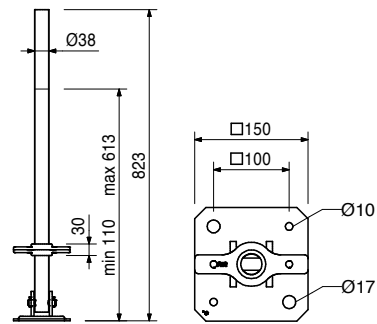
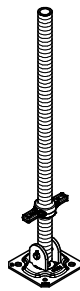

Accessories

100863	1.020
--------	-------

Spindle Locking UJS

130518	13.200
130858	14.200

Base Frame EVB
Base Frame EVB 67
Base Frame EVB 100

X

670

1000

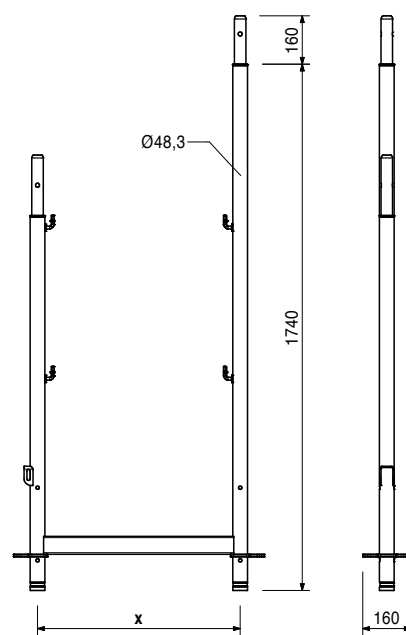
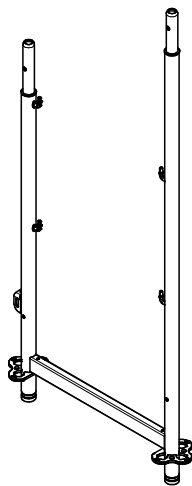

Article no. Weight kg

Article no.	Weight kg		X
130466	11.500	Easy Standard EVF	670
130860	12.500	Easy Standard EVF 67	1000
		Easy Standard EVF 100	

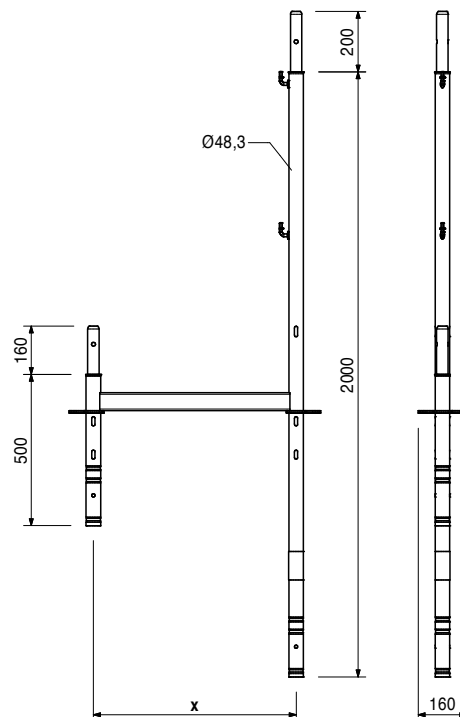
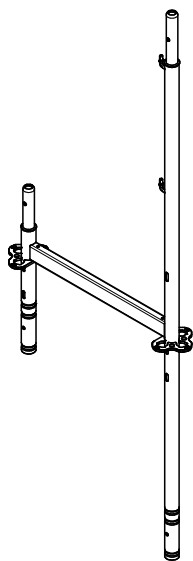

130481 5.130

Tube EVR 150
Complements Easy Standard EVF.

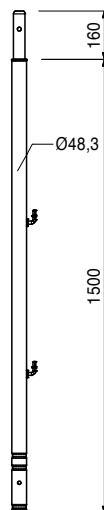

Article no. Weight kg

129314	8.370
130804	9.390

Head Frame EVH
Head Frame EVH 67
Head Frame EVH 100

For completing the top section of the scaffold when using Console Bracket ECM to increase the width of the scaffold.

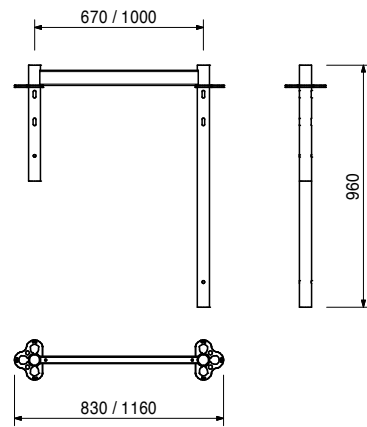
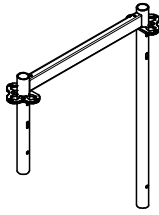

130512	3.720
--------	-------

Guardrail Post EVP

For completing the scaffold in conjunction with Console Brackets ECM or Protection Panel Posts EPS.

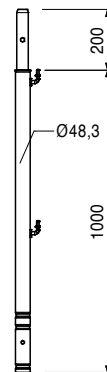

130522	7.020
130854	8.040

Base Compensation EVA
Base Compensation EVA 67/50
Base Compensation EVA 100/50

Facilitates height adjustments.

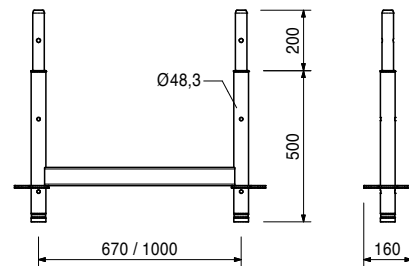
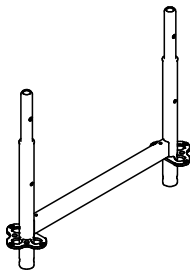

Article no. Weight kg

130526	10.000	Base Compensation EVA
130856	11.100	Base Compensation EVA 67/100
		Base Compensation EVA 100/100

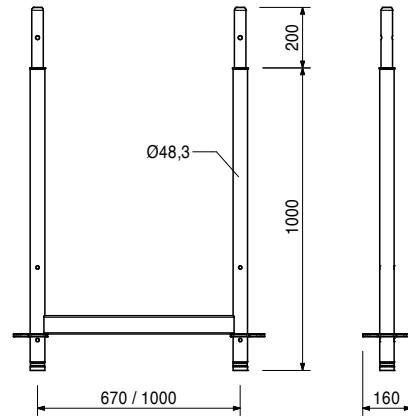
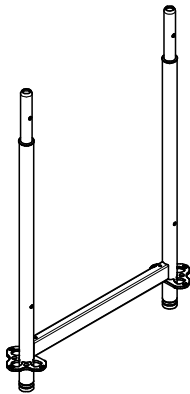

130619 5.260 **Easy Base Standard EVS 124**

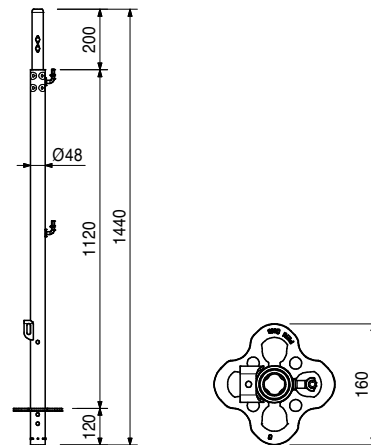

Article no. Weight kg

130621 7.450

Easy Standard EVM 200

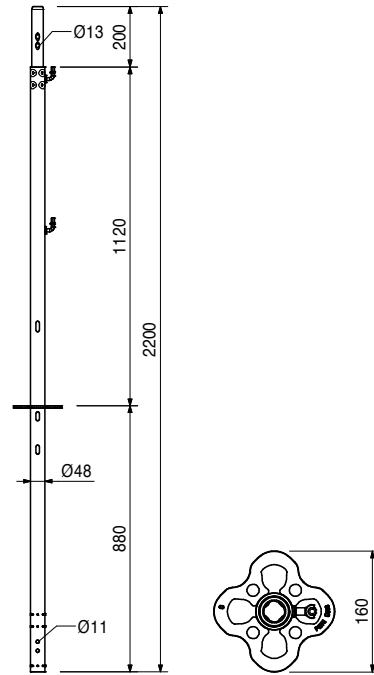

135972 4.310

Top Standard EVT 96

For completing the top section of the scaffold when using Console Bracket ECM in conjunction with Easy Standard EVM to increase the width of the scaffold.

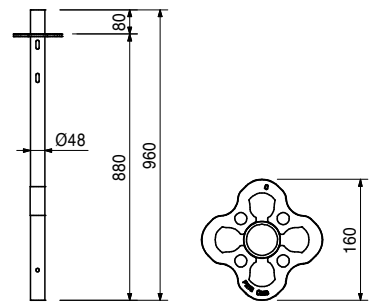
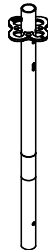

Article no. Weight kg

Article no.	Weight kg	Horizontal Ledger UH-2
131995	1.410	Horizontal Ledger UH-2 25
133900	1.590	Horizontal Ledger UH-2 33
131998	2.030	Horizontal Ledger UH-2 50
133903	2.480	Horizontal Ledger UH-2 67
132213	2.690	Horizontal Ledger UH-2 75
132004	3.740	Horizontal Ledger UH-2 100
132007	4.510	Horizontal Ledger UH-2 125
132010	4.680	Horizontal Ledger UH-2 150
132013	5.340	Horizontal Ledger UH-2 175
132016	6.000	Horizontal Ledger UH-2 200
132019	6.660	Horizontal Ledger UH-2 225
132025	7.320	Horizontal Ledger UH-2 250
132022	8.650	Horizontal Ledger UH-2 300

L	X
204	250
284	330
454	500
624	670
704	750
954	1000
1204	1250
1454	1500
1704	1750
1954	2000
2204	2250
2454	2500
2954	3000

Note

With length marking for easier identification.

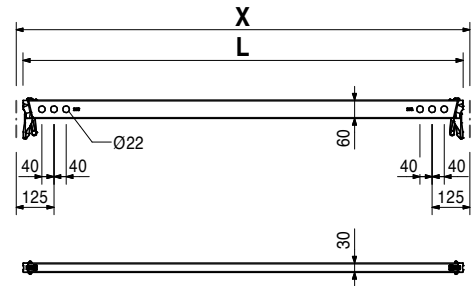
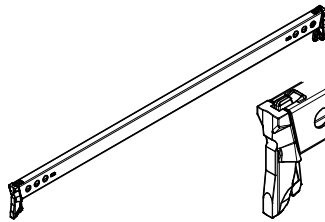

Article no.	Weight kg	Horizontal Ledger UH Plus
414613	1.420	Horizontal Ledger UH 25 Plus
414595	2.070	Horizontal Ledger UH 50 Plus
429982	2.520	Horizontal Ledger UH 67 Plus
414629	2.730	Horizontal Ledger UH 75 Plus
414632	4.390	Horizontal Ledger UH 100 Plus
414638	5.340	Horizontal Ledger UH 125 Plus
414641	4.720	Horizontal Ledger UH 150 Plus
417032	5.380	Horizontal Ledger UH 175 Plus
414645	6.040	Horizontal Ledger UH 200 Plus
416356	6.700	Horizontal Ledger UH 225 Plus
414648	7.360	Horizontal Ledger UH 250 Plus
414651	8.680	Horizontal Ledger UH 300 Plus

L	X
204	250
454	500
624	670
704	750
954	1000
1204	1250
1454	1500
1704	1750
1954	2000
2204	2250
2454	2500
2954	3000

Note

With length marking for easier identification.

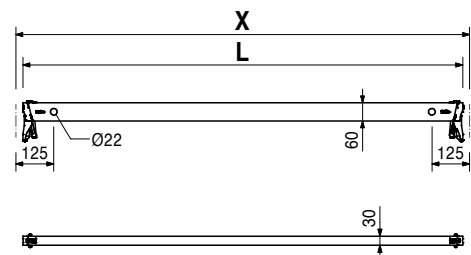
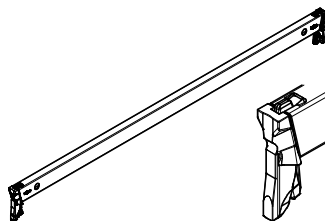

Article no. Weight kg

Article no.	Weight kg		L	X
137020	9.410	Horizontal Ledger UHV-2	1454	1500
137025	12.700	Horizontal Ledger UHV-2 150	1954	2000
137030	15.200	Horizontal Ledger UHV-2 200	2454	2500
137035	18.500	Horizontal Ledger UHV-2 250	2954	3000
		Horizontal Ledger UHV-2 300		

For high loads, e.g. in the case of material storage.

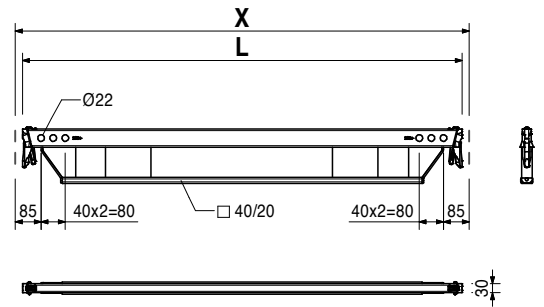
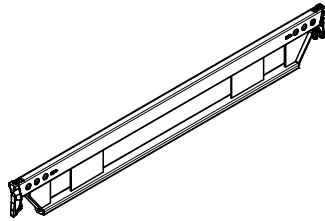

Article no.	Weight kg		L	X
414681	10.900	Horizontal Ledger UHV Plus	1454	1500
414687	14.700	Horizontal Ledger UHV 150 Plus	1954	2000
414691	17.900	Horizontal Ledger UHV 200 Plus	2454	2500
414695	21.600	Horizontal Ledger UHV 250 Plus	2954	3000
		Horizontal Ledger UHV 300 Plus		

For high loads, e.g. in the case of material storage.

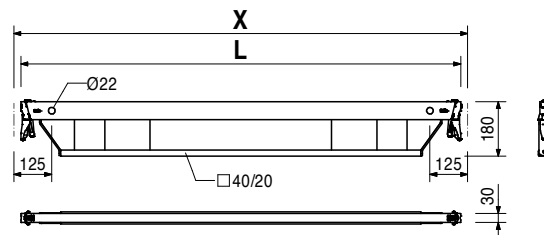
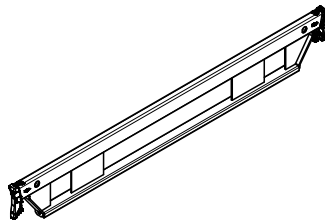

Article no.	Weight kg		L	X
130009	3.410	Coupling Latch UHC	670	780
127537	5.310	Coupling Latch UHC 67	1000	1110
		Coupling Latch UHC 100		

For deck levels at any height and bracing of form-work girders.

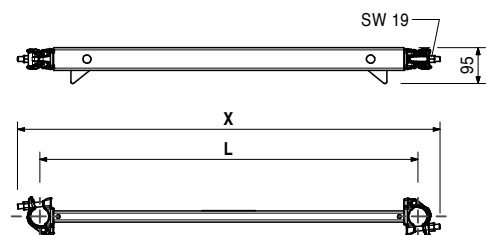
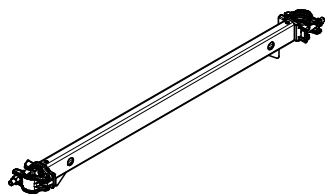

Article no. Weight kg

		Face Braces EBF
130162	5.030	Face Brace EBF 150/200
130171	5.750	Face Brace EBF 200/200
130180	6.570	Face Brace EBF 250/200
130189	7.460	Face Brace EBF 300/200

L	X	Y
2216	1500	2000
2577	2000	2000
2979	2500	2000
3406	3000	2000

Note

With length marking for easier identification.

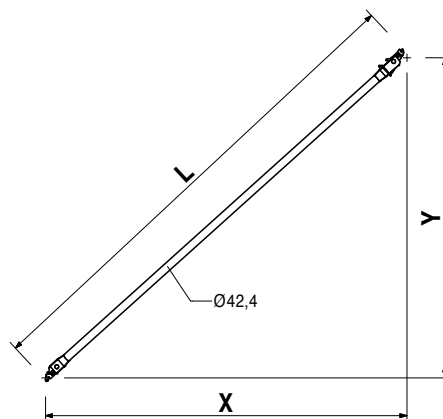
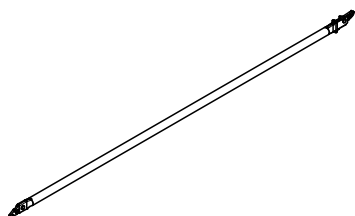

131863 1.230

Brace Adapter EBA

Used for connection of one or two Face Braces EBF.

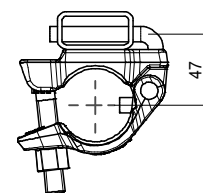
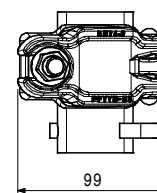
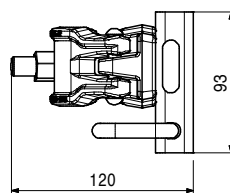
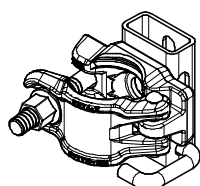

Article no. Weight kg

130450	5.420
130448	7.360
130445	10.300
130441	13.300
130438	16.200
129272	19.200

- Steel Decks EDS 33**
- Steel Deck EDS 33 x 67**
- Steel Deck EDS 33 x 100**
- Steel Deck EDS 33 x 150**
- Steel Deck EDS 33 x 200**
- Steel Deck EDS 33 x 250**
- Steel Deck EDS 33 x 300**

Installation on crossbar of the frame components or on Horizontal Ledger UH.

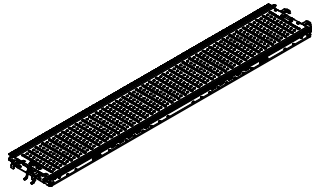

X	perm. p [kN/m ²]
670	6.0
1000	6.0
1500	6.0
2000	6.0
2500	4.5
3000	3.0

Note
Values correspond with EN 12811-1.

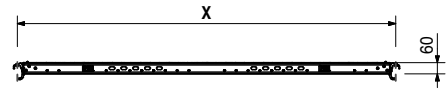

131789	12.100
131791	15.100
131788	18.500
131790	22.400

- Combi Decks EDW-2 67**
- Combi Deck EDW-2 67 x 150**
- Combi Deck EDW-2 67 x 200**
- Combi Deck EDW-2 67 x 250**
- Combi Deck EDW-2 67 x 300**

Deck surface made of coated plywood board.

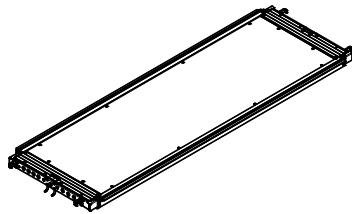

X	perm. p [kN/m ²]
1500	2.0
2000	2.0
2500	2.0
3000	2.0

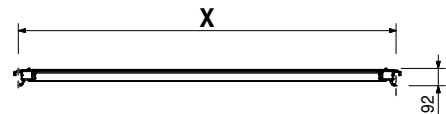

130321	13.200
130317	16.300
130313	19.700
130309	22.800

- Combi Decks EDW**
- Combi Deck EDW 150**
- Combi Deck EDW 200**
- Combi Deck EDW 250**
- Combi Deck EDW 300**

Deck surface made of coated plywood board.

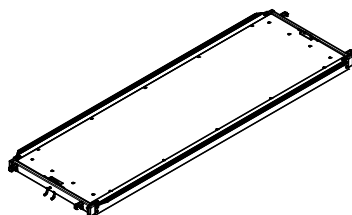

X	perm. p [kN/m ²]
1500	2.0
2000	2.0
2500	2.0
3000	2.0

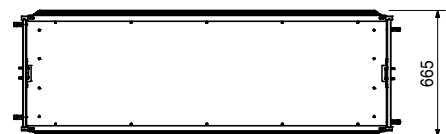
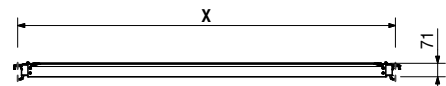

Article no. Weight kg

132928 15.900

Entry Platform EAW-2 67 x 200

Deck surface made of coated plywood board.

Technical data

Load Class 3, 2.0 kN/m²

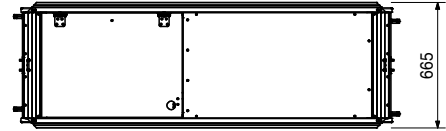
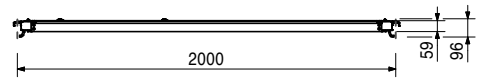
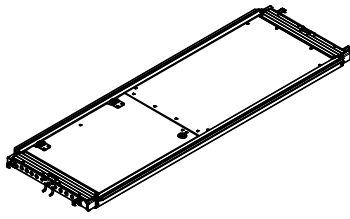

Accessories

109879 3.820

Ladder UAF 200, Aluminium

130426 18.400

Entry Platform EAW 200

Deck surface made of coated plywood board.

Technical data

Load Class 3, 2.0 kN/m²

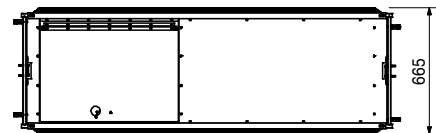
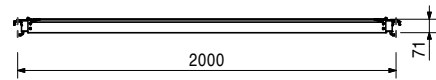
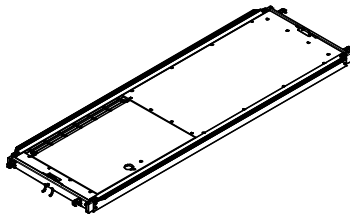

133286 24.100
133285 27.300

Access Decks EAW-2, 67
Access Deck EAW-2 67 x 250-L
Access Deck EAW-2 67 x 300-L

Deck surface made of coated plywood board.

Technical data

Load Class 3, 2.0 kN/m²

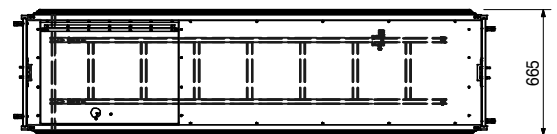
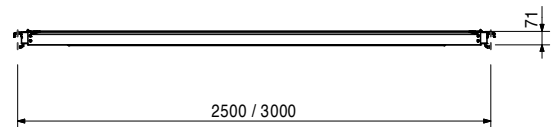
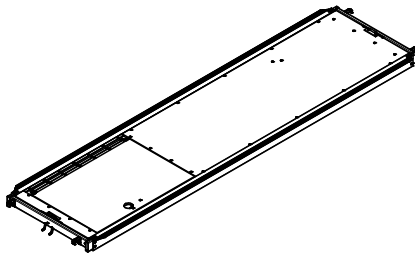

Article no. Weight kg

130431	25.800
130425	29.200

Access Decks EAW

Access Deck EAW-L 250

Access Deck EAW-L 300

Deck surface made of coated plywood board.

Technical data

Load Class 3, 2.0 kN/m²

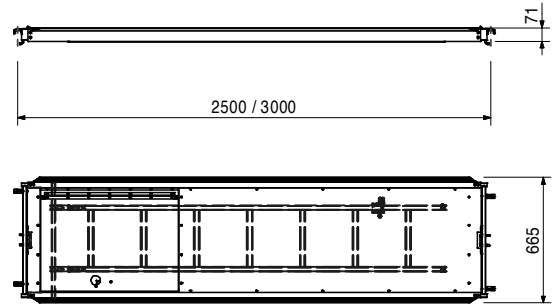
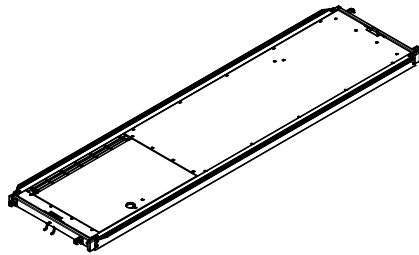

133525	6.360
133524	8.420
133523	11.500
133522	14.700
133521	17.800
133492	21.000

Aluminium Deck EDA 67

Aluminium Deck EDA 67 x 67

Aluminium Deck EDA 67 x 100

Aluminium Deck EDA 67 x 150

Aluminium Deck EDA 67 x 200

Aluminium Deck EDA 67 x 250

Aluminium Deck EDA 67 x 300

Deck surface made of aluminium profiles.

X	perm. p [kN/m ²]
670	6.0
1000	3.0
1500	3.0
2000	3.0
2500	3.0
3000	2.0

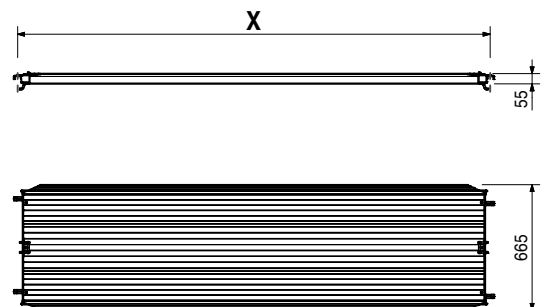
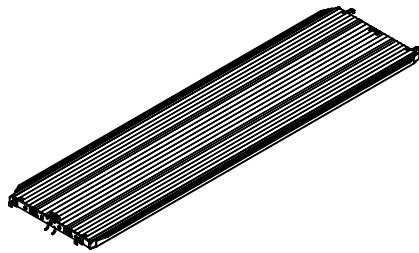

132882	17.500
--------	--------

Entry Platform EAA 67 x 200

Deck surface made of aluminium profiles.

Technical data

Load Class 3, 2.0 kN/m²

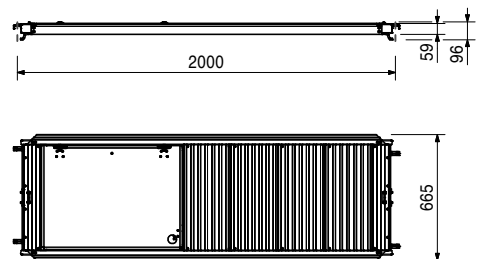
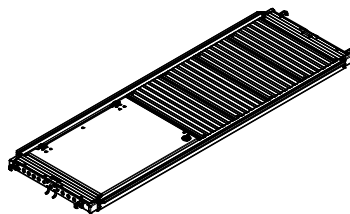

109879	3.820
--------	-------

Accessories

Ladder UAF 200, Aluminium

Article no. Weight kg

133289	25.200
133287	28.300

Access Decks EAA 67
Access Decks EAA 67 x 250-L
Access Decks EAA 67 x 300-L

Deck surface made of aluminium profiles.

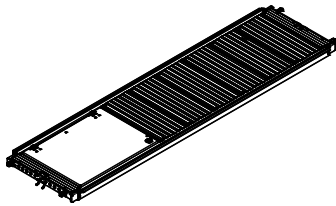

Technical data
 Load Class 3, 2.0 kN/m²

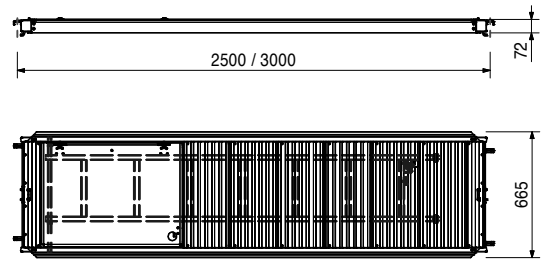

135376	12.500
135375	15.600
135374	19.200
135365	23.200

Composite Deck EDC 67
Composite Deck EDC 67 x 150
Composite Deck EDC 67 x 200
Composite Deck EDC 67 x 250
Composite Deck EDC 67 x 300

Deck surface made of glass-fibre reinforced plastic.

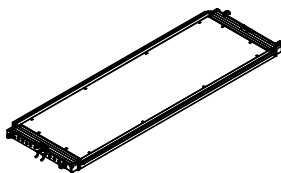

L
1500
2000
2500
3000

Technical data
 Load Class 3, 2.0 kN/m²

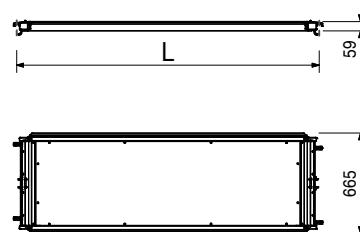

135369	16.500
--------	--------

Entry Platform EAC 67 x 200
 Deck surface made of glass-fibre reinforced plastic.

Technical data
 Load Class 3, 2.0 kN/m²

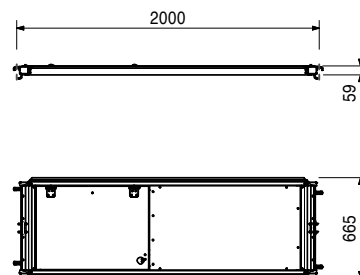
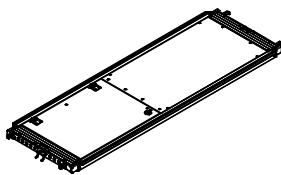

109879	3.820
--------	-------

Accessories
Ladder UAF 200, Aluminium

Article no. Weight kg

135368	24.800
135367	28.100

Access Decks EAC 67
Access Decks EAC 67 x 250-L
Access Decks EAC 67 x 300-L

Deck surface made of glass-fibre reinforced plastic.

Technical data
 Load Class 3, 2.0 kN/m²

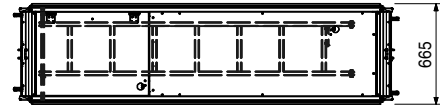
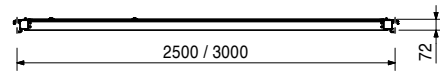
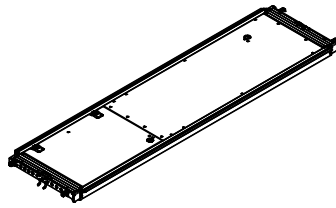

109879 3.820

Ladder UAF 200, Aluminium

To mount on the Passage Deck EAW, EAA, EAC 200.

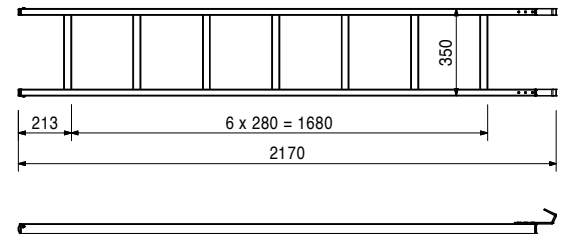
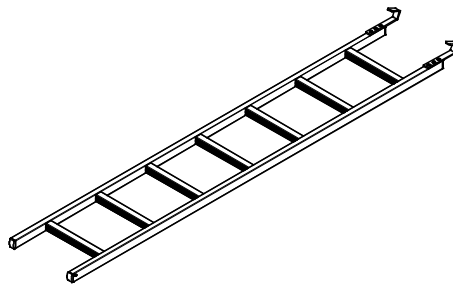

134539 6.270

Deck Compensation EDL 33

For compensation lengths of up to 67 cm.

Note
 Load Class 4, 3.0 kN/m².

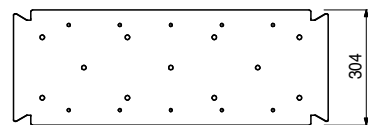
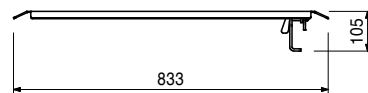
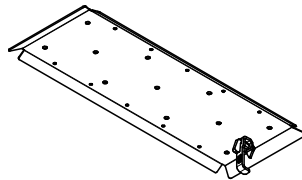

136925 4.250

Cover Plate UDB 20 x 150

Note
 Load class 3, 2.0 kN/m²

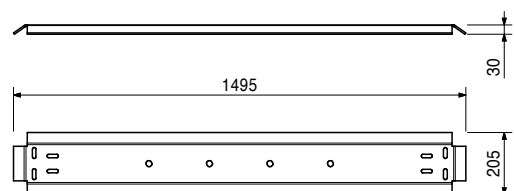
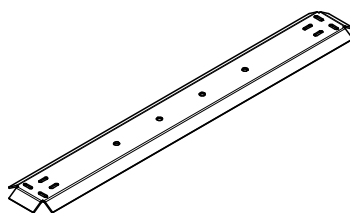

Accessories

137279	0.100
137252	0.200

Hex nut ISO 4032 M10-8, galv. SW17
FLRD screw M 10 x 60 DIN 603, 8.8, galv.

Article no. Weight kg

136927	2.780	Cover Plate UDB 20 x 100
--------	-------	---------------------------------

Note

Load class 3, 2.0 kN/m²

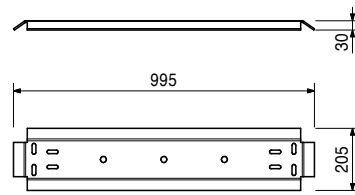
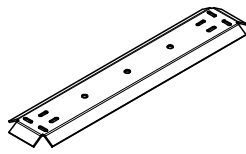

Accessories

137252	0.200	FLRD screw M 10 x 60 DIN 603, 8.8, galv.
137279	0.100	Hex nut ISO 4032 M10-8, galv. SW17

		Inside Corner Plates EDP
134549	2.800	Inside Corner Plate 25
134552	4.940	Inside Corner Plate 33

L

290

378

Note

Load Class 4, 3.0 kN/m².

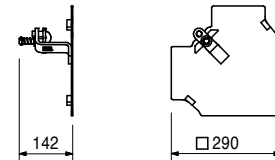
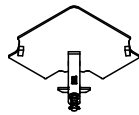

		Guardrail Posts EPG
130191	1.150	Guardrail Post EPG 67
130193	1.680	Guardrail Post EPG 100
130195	2.480	Guardrail Post EPG 150
130197	3.280	Guardrail Post EPG 200
130199	4.090	Guardrail Post EPG 250
130201	4.890	Guardrail Post EPG 300

L

735

1065

1565

2065

2565

3065

X

670

1000

1500

2000

2500

3000

Note

With length marking for easier identification.

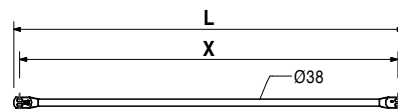
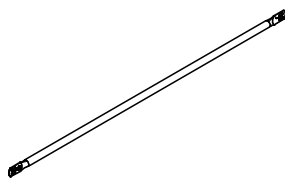

Article no. Weight kg

130434 1.100

Guardrail Coupling EPR

For installing the Guardrail Posts EPG on the scaffold standards at any height.

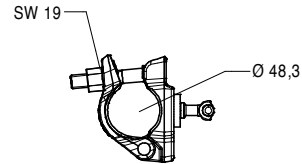
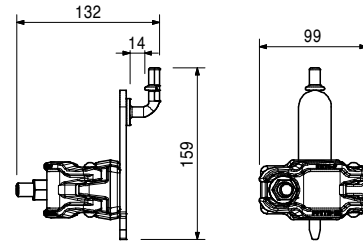
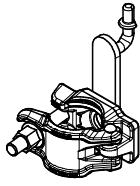

130562 0.623

Guardrail Holder EPW

For installing the Guardrail Posts EPG to rosettes.

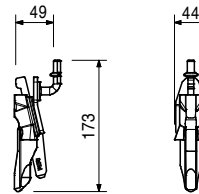

134100 6.730
134104 8.100

End Guardrail End Guardrail UPA-2
End Guardrail End Guardrail UPA-2 67
End Guardrail iEnd Guardrail UPA-2 100

Assembly in advance.

L	X
801	670
1131	1000

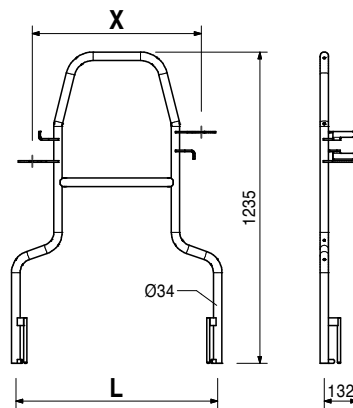
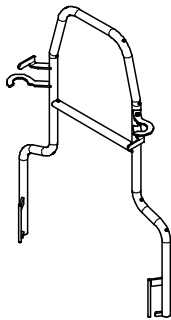

Article no. Weight kg

130476	6.230
130583	7.600

End Guardrail iEnd Guardrail UPA
End Guardrail End Guardrail UPA 67
End Guardrail End Guardrail UPA 100

Assembly in advance.

L	X
801	670
1131	1000

Note

Wood toe board/steel toe board not integrated.

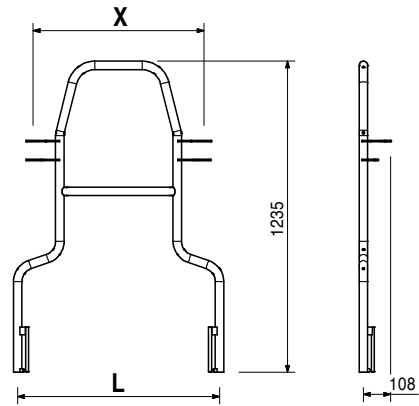
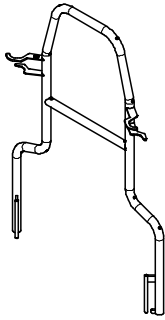

130233	4.480
--------	-------

End Guardrail EPF 33

Assembly not in advance.

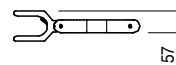
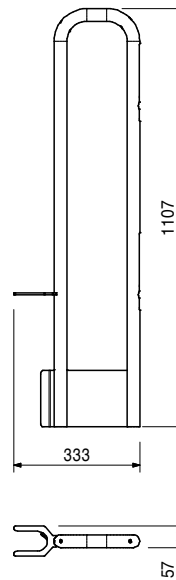
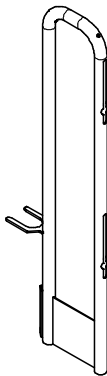

Article no. Weight kg

Article no.	Weight kg		L
130228	3.630	End Guardrail EPF	683
130225	4.660	End Guardrail EPF 67	1013
		End Guardrail EPF 100	

Assembly not in advance.

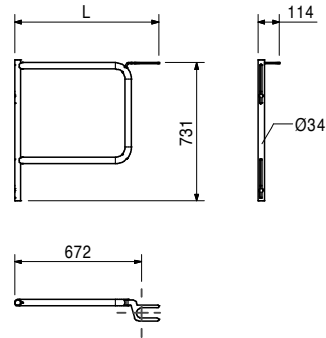
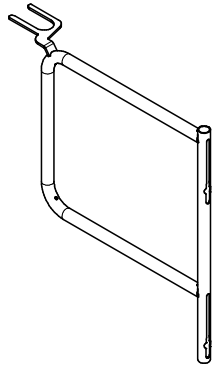

Article no.	Weight kg		X
129490	1.180	Wood Toe Boards UPF	500
129492	1.550	Wood Toe Board UPF 50	670
129496	2.250	Wood Toe Board UPF 67	1000
129498	3.320	Wood Toe Board UPF 100	1500
129500	4.390	Wood Toe Board UPF 150	2000
129502	5.460	Wood Toe Board UPF 200	2500
129504	6.520	Wood Toe Board UPF 250	3000
		Wood Toe Board UPF 300	

Note

- Default surface: painted yellow.

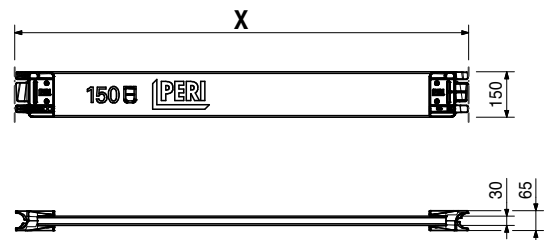
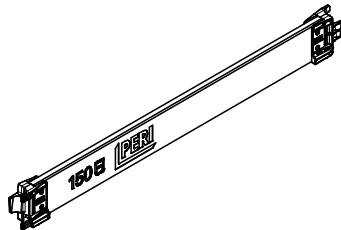

Article no.	Weight kg		X
132555	1.180	Wood Toe Boards UPF-C	500
132556	1.550	Wood Toe Board UPF 50-C	670
132557	1.720	Wood Toe Board UPF 67-C	750
132558	2.250	Wood Toe Board UPF 100-C	1000
132559	3.320	Wood Toe Board UPF 150-C	1500
132560	4.390	Wood Toe Board UPF 200-C	2000
132561	5.460	Wood Toe Board UPF 250-C	2500
132562	6.520	Wood Toe Board UPF 300-C	3000

Customised toe board wood design in RAL colour scheme possible on request.

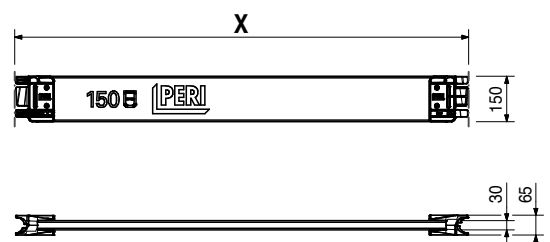
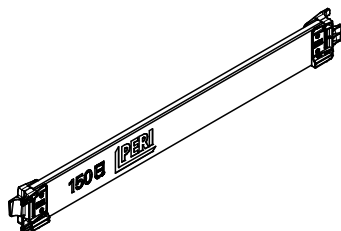

Article no. Weight kg

Article no.	Weight kg	Steel Toe Boards UPY
132592	0.414	Steel Toe Board UPY 25
110213	0.929	Steel Toe Board UPY 50
129947	1.280	Steel Toe Board UPY 67
110073	1.960	Steel Toe Board UPY 100
110160	2.990	Steel Toe Board UPY 150
110176	4.030	Steel Toe Board UPY 200
110208	5.060	Steel Toe Board UPY 250
110211	6.090	Steel Toe Board UPY 300

L	X
236	250
486	500
656	670
986	1000
1486	1500
1986	2000
2486	2500
2986	3000

Note

- Default surface: galvanised and painted in yellow.

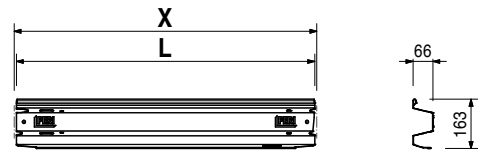
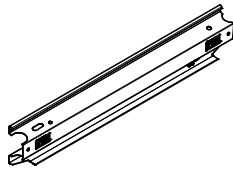

Article no.	Weight kg	Steel Toe Boards UPY-C
134643	0.414	Steel Toe Board UPY 25-C
134642	0.929	Steel Toe Board UPY 50-C
134641	1.280	Steel Toe Board UPY 67-C
134640	1.450	Steel Toe Board UPY 75-C
134639	1.960	Steel Toe Board UPY 100-C
134638	2.480	Steel Toe Board UPY 125-C
134637	2.990	Steel Toe Board UPY 150-C
134636	4.030	Steel Toe Board UPY 200-C
134635	5.060	Steel Toe Board UPY 250-C
134634	6.090	Steel Toe Board UPY 300-C

L	X
236	250
486	500
656	670
736	750
986	1000
1236	1250
1486	1500
1986	2000
2486	2500
2986	3000

Customised toe board steel design in RAL colour scheme possible on request.

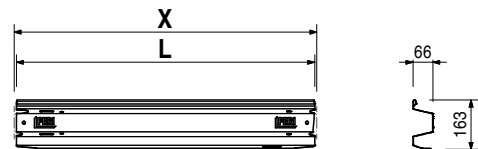
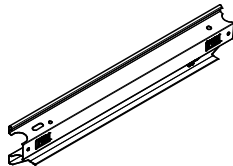

Article no.	Weight kg	Toe Board Compensation UPY-L
134542	0.606	Connection component for connection of 2 x Toe Boards UPY.

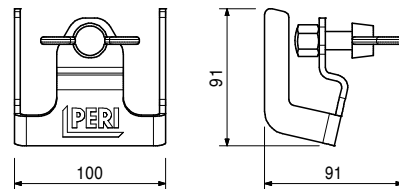
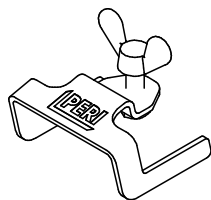

Article no. Weight kg

115959	1.160	Supports UC
130390	1.360	Support UC 25
		Support UC 33

L	X
250	223
330	301

Note

Small console brackets with limit stop for fixing the decks in place.

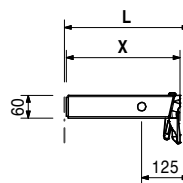
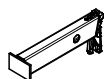

136050 1.880 **Support UCS 33**

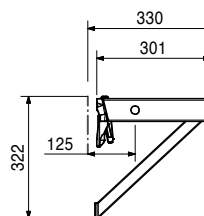
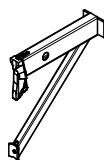

130378 4.550 **Console Bracket ECM 33**

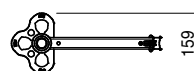
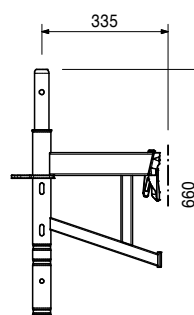
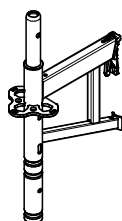

Article no. Weight kg

130372

7.430

Console Bracket ECM 67

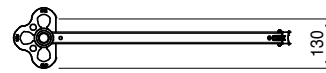
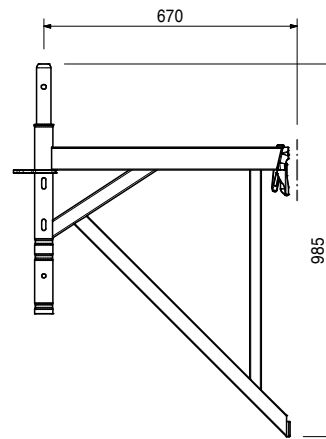
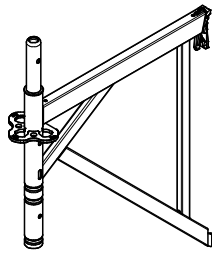

130365

11.200

Console Bracket ECM 100

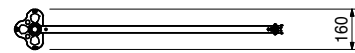
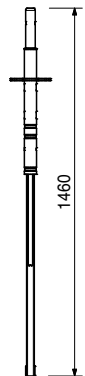
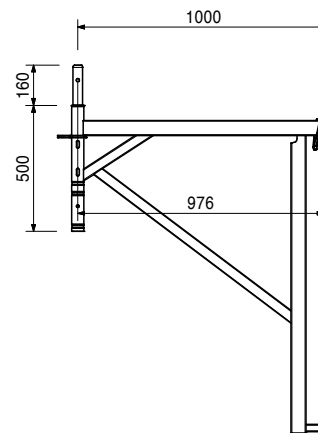
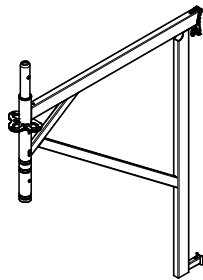

Article no. Weight kg

130532 6.640

Protection Panel Post EPS

For assembling a protection panel.

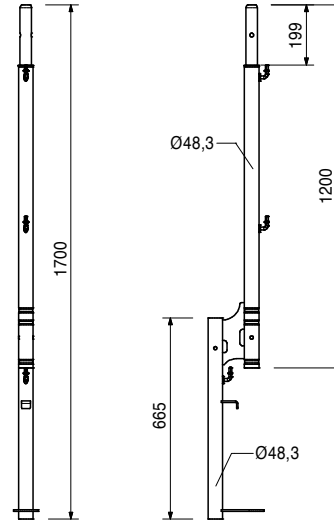

Accessories

130512 3.720

Guardrail Post EVP

130385 2.970

Protection Roof Connector EPC

For assembling a protection roof.

Note

Alternative accessories:
100719 Bolt ISO 4014 M10 x 70-8.8

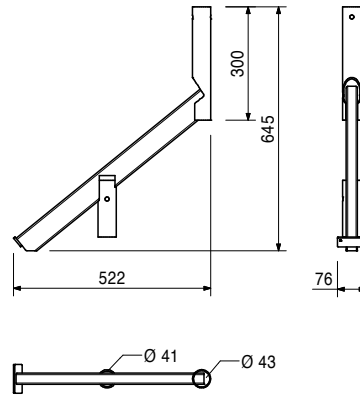
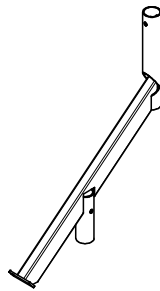

Accessories

123480 0.080

Tube clip 10 x 60, galv.

131093 23.700

Multi Brace EWB

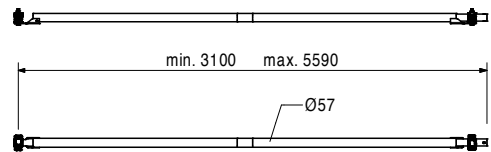
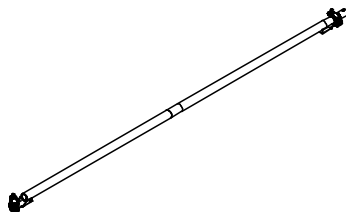

Accessories

131097 1.700

Base plate for EWB

Article no. Weight kg

131092 9.090

Scaffold support, coated

Can be used as an additional inner tube for the EWB Multi Brace if required.

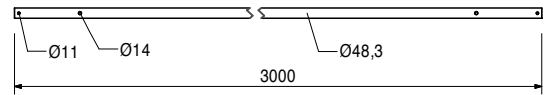
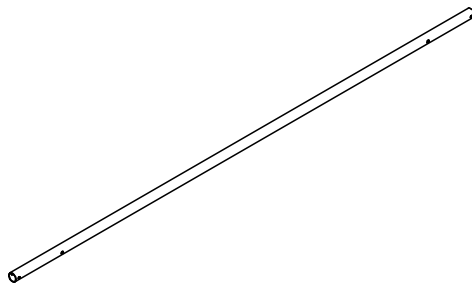

131097 1.700

Base plate for EWB

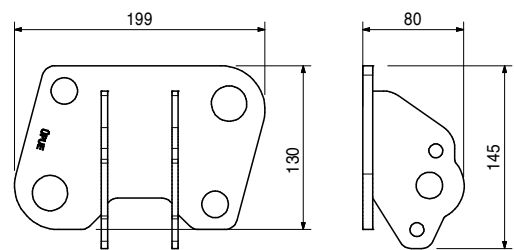
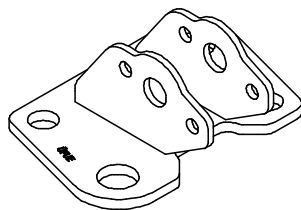

Accessories

710593 0.062

Bolt ISO 4014 M10 x 80-8.8, galv.

112786 0.015

Nut EN 1661 M10-8, galv.

131723 1.440

Brace Connector HDR-2

For connecting push-pull props and kicker braces to components with Ø 48 mm.

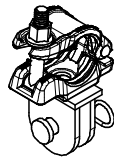

Complete with

1 pc. 027170 bolt Ø 16 x 42, galv.

1 pc. 018060 cotter pin 4/1, galv.

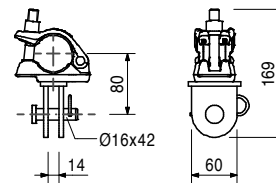

117469 39.900

Push-pull Prop RS 650, galv.

Extension length L = 4.30 – 6.50 m.

For aligning PERI formwork systems and precast concrete elements.

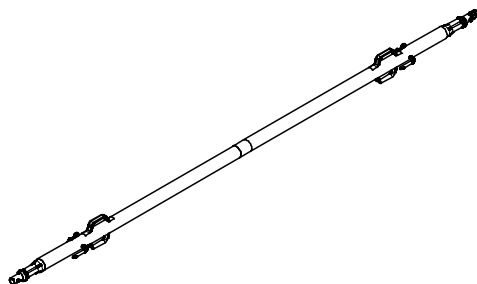

Note

See PERI Design Tables for permissible load.

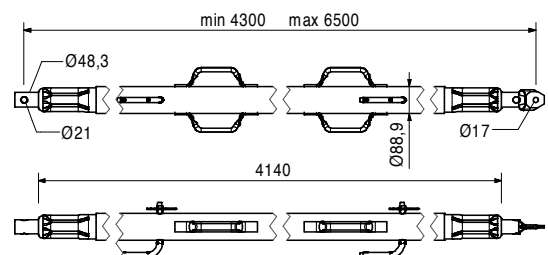

Article no. Weight kg

134005 2.710

Console Bracket UCB 25

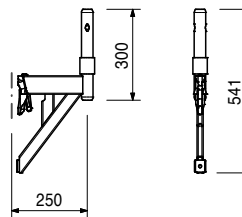

133499

2.270

Base Standard UVB 25

For fitting directly onto the base spindles.
Can also be used as 25 cm standard.

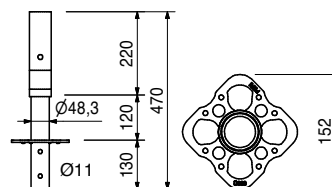
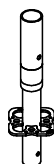

135187

3.590

Base Standard UVB 50

For fitting directly onto the base spindles.

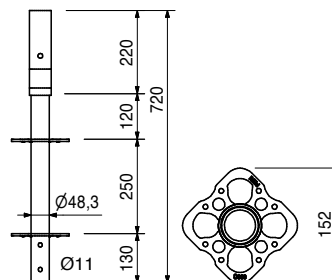
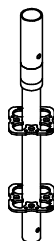

400014

2.470

Base Standard UVB 24

For fitting directly onto the base spindles.

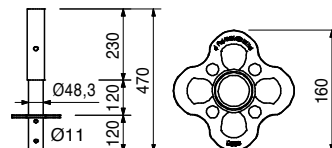
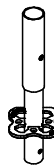

Article no. Weight kg

417194 3.980

Base Standard UVB 49

For fitting directly onto the base spindles. Reduces necessary spindle extensions with 25 cm rosette spacing.

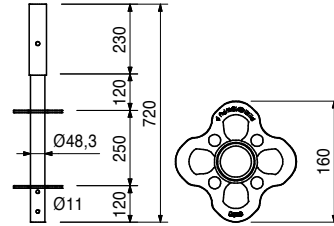

		Top Standards UVH-2	L
132123	2.100	Top Standard UVH-2 50	500
132194	4.210	Top Standard UVH-2 100	1000
132196	6.060	Top Standard UVH-2 125	1250
132198	6.310	Top Standard UVH-2 150	1500
132200	8.420	Top Standard UVH-2 200	2000
132202	10.500	Top Standard UVH-2 250	2500

Without pin for mounting head spindles.

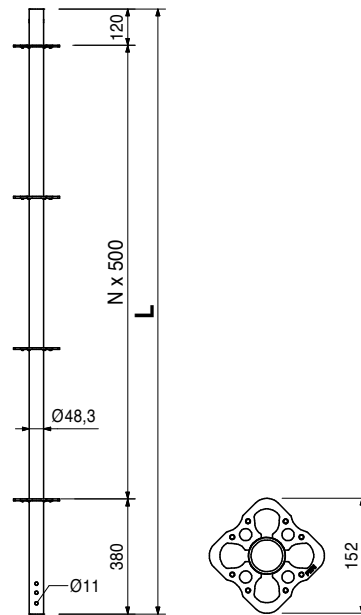

Article no. Weight kg

Article no.	Weight kg	Top Standards UVH	L
401309	2.510	Top Standard UVH 50	500
400000	4.610	Top Standard UVH 100	1000
417195	7.600	Top Standard UVH 125	1250
400003	6.920	Top Standard UVH 150	1500
400005	9.240	Top Standard UVH 200	2000
400007	11.500	Top Standard UVH 250	2500

Without pin for mounting head spindles.

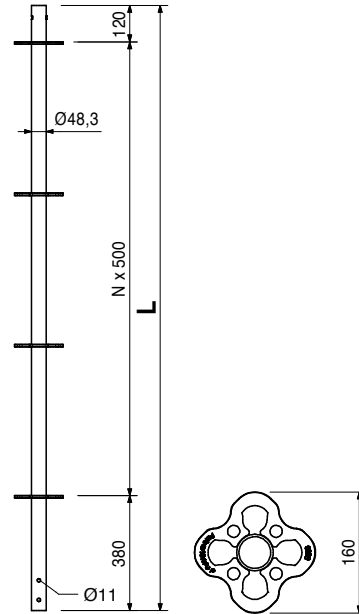

Article no.	Weight kg	Standards UVR-2	L
132219	2.490	Standard UVR-2 50	500
132224	4.350	Standard UVR-2 100	1000
132229	6.190	Standard UVR-2 150	1500
132234	8.040	Standard UVR-2 200	2000
132239	11.700	Standard UVR-2 300	3000

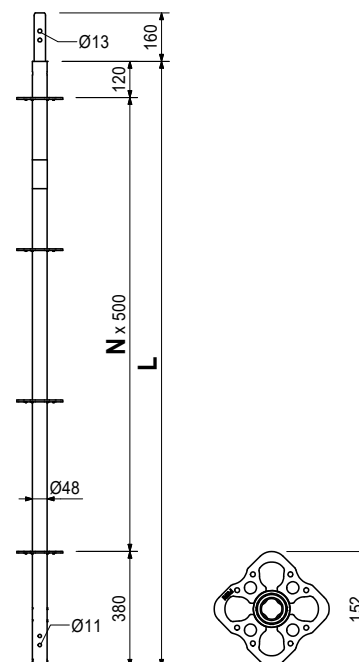
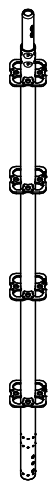

Article no. Weight kg

		Standards UVR	L
402859	3.080	Standard UVR 50	500
401306	5.380	Standard UVR 100	1000
402860	7.690	Standard UVR 150	1500
400009	10.000	Standard UVR 200	2000
400012	14.700	Standard UVR 300	3000
400013	19.200	Standard UVR 400	4000

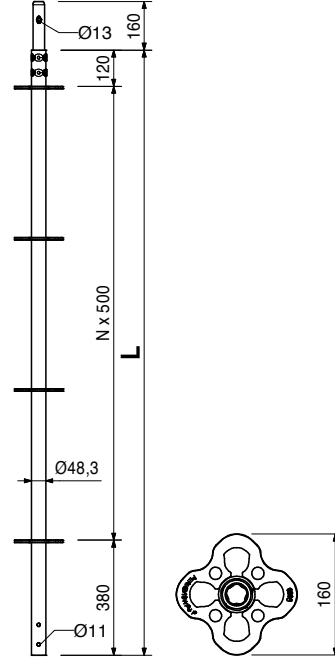

105372 1.340

Spigot w. Spacer Tube URE 4/42

For attaching to Element Collar URP, Connector ULS Flex and Head Frame EVH. Spacer tube enables further installation in the system grid.

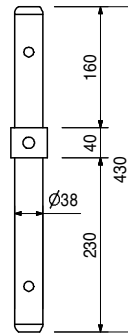

780356 0.011
100719 0.060

Accessories

Nut ISO 7040 M10-8, galv.
Bolt ISO 4014 M10 x 70-8.8

Article no. Weight kg

131368 25.800

Multi Girder ELM

e.g. suitable for the use of pavement gantries!

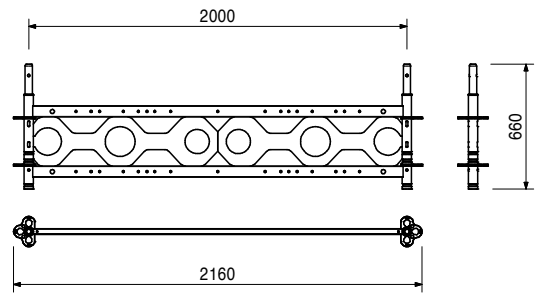
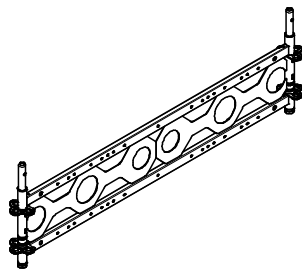

Accessories

130681 1.360
130684 2.020

UH Spigot-2

Ledger-To-Ledger Coupler UHA-2 half with pin

130681 1.360

UH Spigot-2

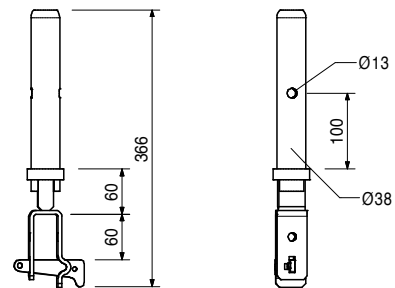
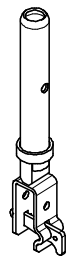

409764 1.250

UH Spigot

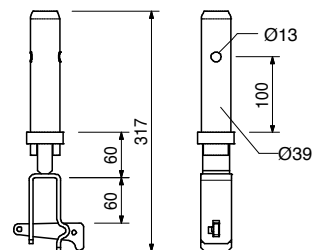
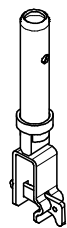

136582 0.829

Ledger-to-Ledger Coupler UHA-2

For connecting horizontal ledgers at right-angles.

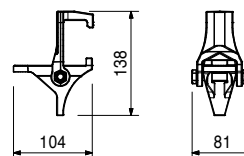
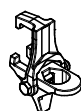

Article no. Weight kg

401731 0.841

Ledger-to-Ledger Coupler UHA

For connecting horizontal ledgers at right-angles.

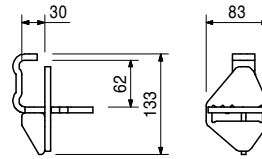

410793 1.090

Ledger-to-Ledger Coupler UHA half

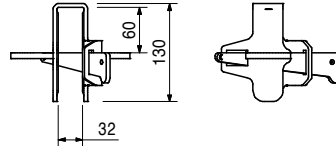
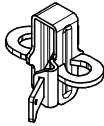

130684 2.020

Ledger-To-Ledger Coupler UHA-2 half with pin

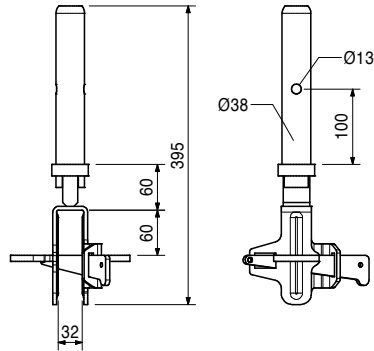
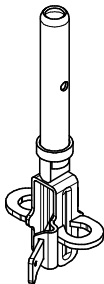

410792 1.900

Ledger-to-Ledger Coupler UHA Half with pin

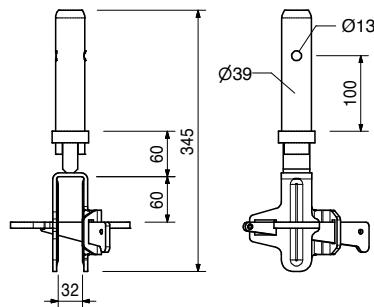
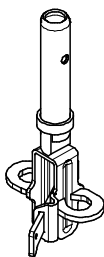

116306 1.700

Clamping Rosette UEV 180 °

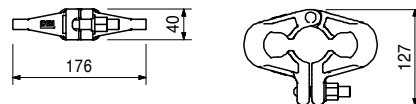
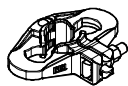

Article no. Weight kg

126453 1.630

Clamping Rosette UEV 90°

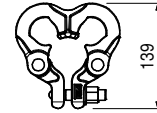
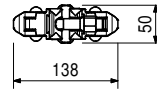
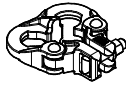

134553 27.000
134554 29.600

Easy Staircase EAS 67
Easy Staircase EAS 67 x 250/200
Easy Staircase EAS 67 x 300/200

Technical data
Permissible load 2.0 kN/m².
Class B according to DIN EN 12811-1.

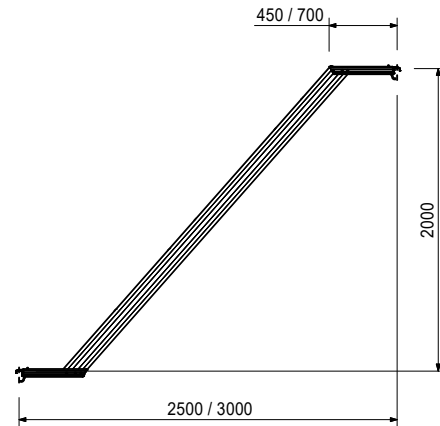

134555 10.700

Easy Staircase EAS 67 x 75/50
Fit onto Horizontal Ledger UH

Technical data
Permissible load 2.0 kN/m².
Class B according to DIN EN 12811-1.

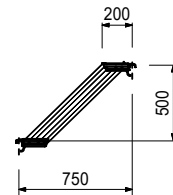
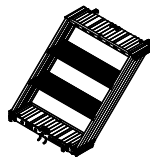

134559 16.500

Easy Staircase EAS 67 x 150/100 T
Fit onto Horizontal Ledger UH

Technical data
Permissible load 2.0 kN/m².
Class B according to DIN EN 12811-1.

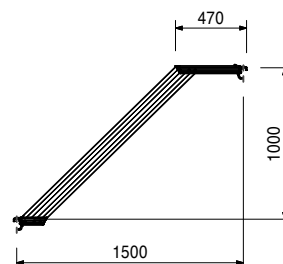
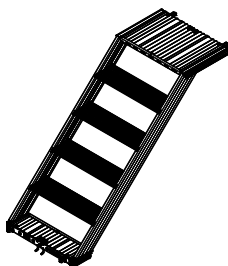

Article no. Weight kg

435769 9.330

Stair Tower UAS 67 x 75/50
Suitable for PERI UP Easy 67.

Technical data
Permissible load 2.0 kN/m².

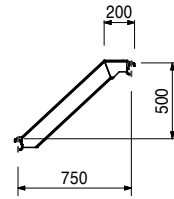
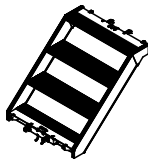

435027 26.100
435026 30.600

Staircases UAS 67
Stair Tower UAS 67 x 250/200
Stair Tower UAS 67 x 300/200
Suitable for PERI UP Easy 67.

Technical data
Permissible load 2.0 kN/m².

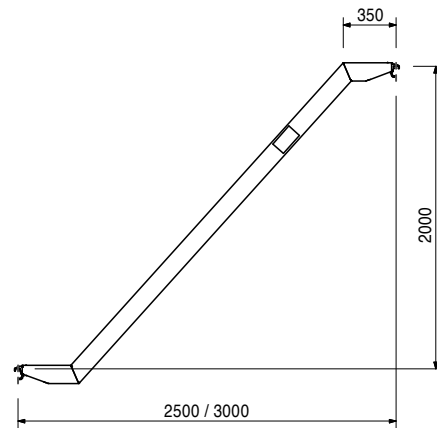
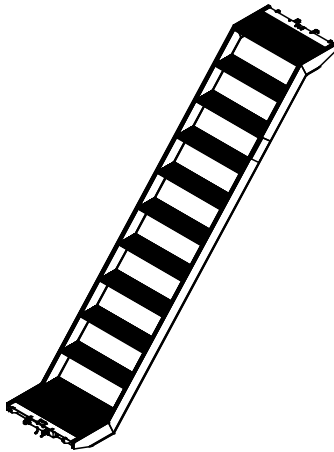

124561 7.180
124558 8.180

Stair Guardrails EAG
Stair Guardrail EAG 250/200
Stair Guardrail EAG 300/200
Suitable for external scaffold access in conjunction with Easy Standard.

L	X
2565	2500
3065	3000

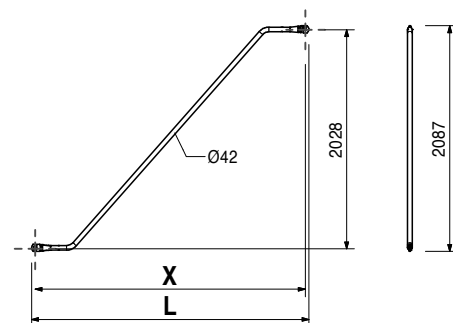
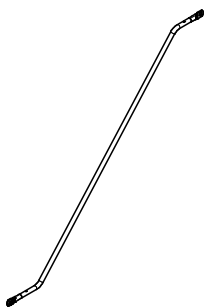

133705 0.549

Accessories
Locking Pin EAG

Article no. Weight kg

133705 0.549

Locking Pin EAG

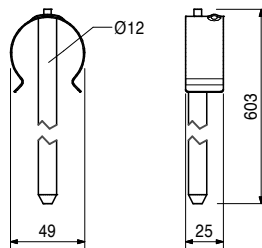
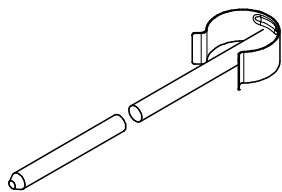

100742 10.000

Stair Guardrail UAG

Suitable for Staircases UAS and EAS as internal and external guardrails.

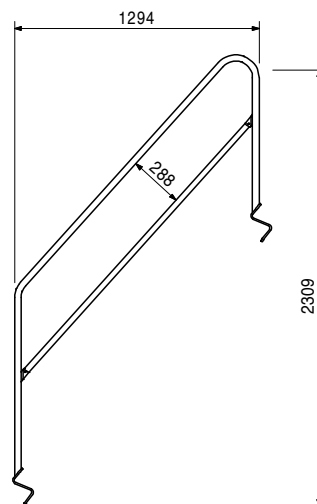
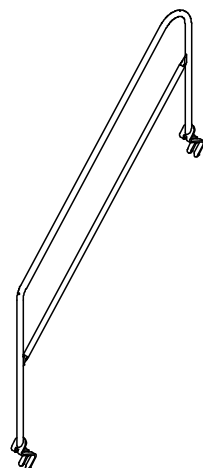

133543 4.510

Stair Guardrail UAH-2

For fixing to the stringers of the Staircases UAS, UAS-2 and EAS.

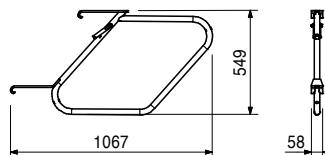
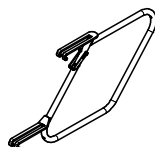

400830 4.970

Stair Guardrail UAH

For fixing to the stringers, but only of Staircase UAS.

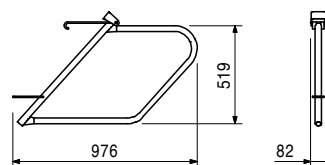
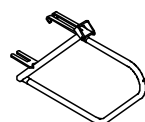

Article no. Weight kg

130964 1.020

Wall Tie Holder EWC

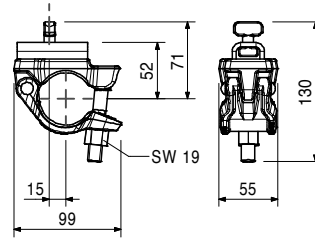
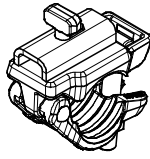

111053 0.059

Locking pin Ø 48/57

As tension-proof connection of standards with a diameter of 48 up to 57 mm.

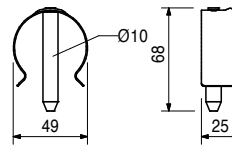

100719 0.060

Bolt ISO 4014 M10 x 70-8.8

As tension-proof connection of standards at suspended scaffolds and formwork girders.

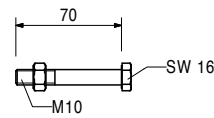
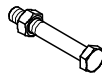

123480 0.080

Tube clip 10 x 60, galv.

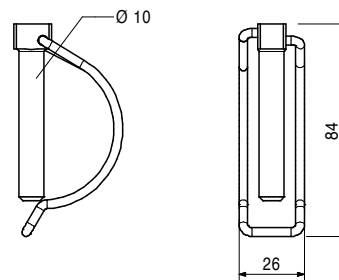
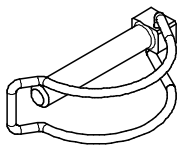

Article no. Weight kg

Article no.	Weight kg		L
100088	1.920	Wall Tie UWT	488
100091	4.680	Wall Tie UWT 45	1138
100093	5.870	Wall Tie UWT 110	1438
102951	7.060	Wall Tie UWT 140	1738
102954	9.050	Wall Tie UWT 170	2238
102957	11.000	Wall Tie UWT 220	2738
		Wall Tie UWT 270	

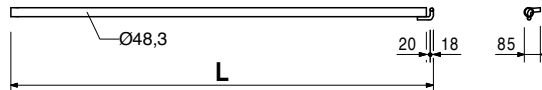
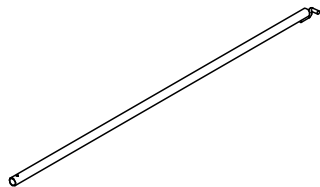

Article no.	Weight kg		Note
100693	0.169	Eyebolts UFE	With marking for screw-in depth.
100694	0.190	Eyebolt UFE 12/90	
100695	0.250	Eyebolt UFE 12/120	
		Eyebolt UFE 12/190	
For assembly of the Wall Tie UWT. Required Expanding Dowel UFI 14.			

Article no.	Weight kg	
100696	0.007	Expanding Dowel UFI
100697	0.009	Expanding Dowel UFI 14/70
100698	0.010	Expanding Dowel UFI 14/100
		Expanding Dowel UFI 14/135

Article no.	Weight kg		L
026415	3.550	Steel scaffold tubes Ø 48.3 x 3.2	
026417	0.000	Steel scaffold tube Ø 48.3 x 3.2, special length	
Cutting costs for scaffold tubes			
026411	3.550	Steel scaffold tube Ø 48.3 x 3.2, L = 1.0 m	1000
026412	7.100	Steel scaffold tube Ø 48.3 x 3.2, L = 2.0 m	2000
026413	10.650	Steel scaffold tube Ø 48.3 x 3.2, L = 3.0 m	3000
026414	14.200	Steel scaffold tube Ø 48.3 x 3.2, L = 4.0 m	4000
026419	17.750	Steel scaffold tube Ø 48.3 x 3.2, L = 5.0 m	5000
026418	21.600	Steel scaffold tube Ø 48.3 x 3.2, L = 6.0 m	6000

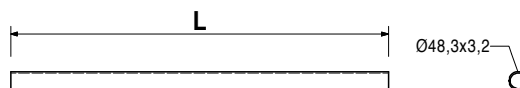
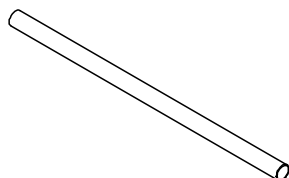

Article no. Weight kg

017020 1.120

Standard Coupler RA 48/48, galv.

For scaffold tubes Ø 48 mm.

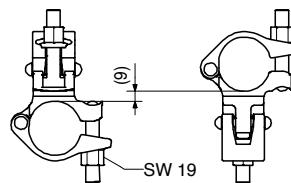
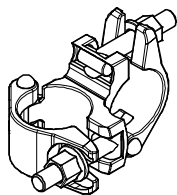

017010 1.400

Swivel Coupling AF 48/48, galv.

For scaffold tubes Ø 48 mm.

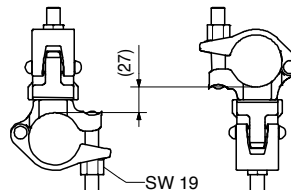
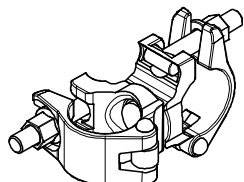

102400 1.100

Red. Swivel Coupling RS 38/48, galv.

For scaffold tubes Ø 48 and Ø 38 mm.

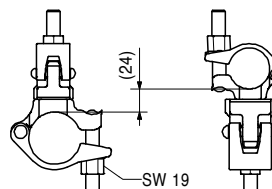
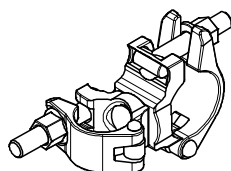

124777 0.210

Tie Bolt PERI 14/20 x 130

For temporary fixing to reinforced concrete components.

Note

Take the PERI Data Sheet into consideration!
Hole Ø 14 mm.

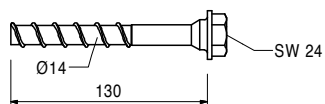
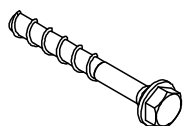

100330	41.700
100336	50.900
100339	60.200
100185	54.800
100183	64.500
100852	83.600

Steel Formwork Girder ULS

Steel Formwork Girder ULS 50/425

Steel Formwork Girder ULS 50/525

Steel Formwork Girder ULS 50/625

Steel Formwork Girder ULS 70/525

Steel Formwork Girder ULS 70/625

Steel Formwork Girder ULS 70/825

For bridging of openings.
For system-independent application.

L	X	Y
4250	4000	500
5250	5000	500
6250	6000	500
5250	5000	700
6250	6000	700
8250	8000	700

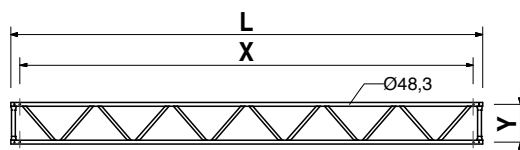
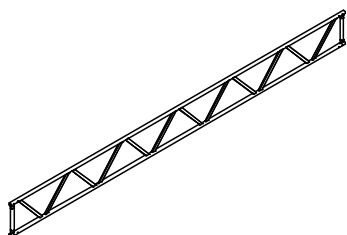

Article no. Weight kg

Article no.	Weight kg		L	X	Y
101656	18.300	Aluminium Formwork Girder ULA	4250	4000	500
101657	22.400	Aluminium Formwork Girder ULA 50/425 HD	5250	5000	500
101658	26.400	Aluminium Formwork Girder ULA 50/625 HD	6250	6000	500
101659	37.300	Aluminium Formwork Girder ULA 70/825 HD	8250	8000	700

For bridging of openings.
For system-independent application.

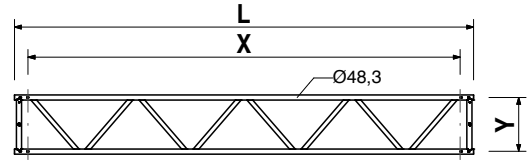
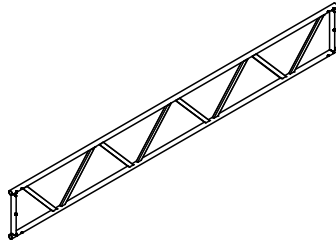

100529	5.260	Starter Tube ULB 50/70, galv.	Note
--------	-------	--------------------------------------	-------------

For Formwork Girders ULS and ULA.

Only to be used for system-independent formwork girder assembly.

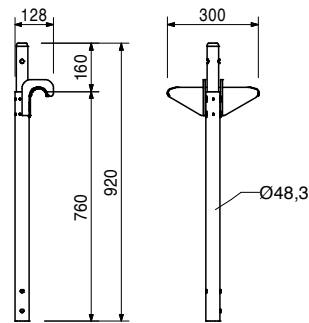
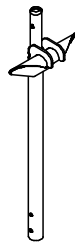

100301	0.969	Spigot ULT 32
--------	-------	----------------------

Single pin for connection of tubes Ø 48.3 x 3.2 mm, e.g. formwork girders or top standards without interlock.

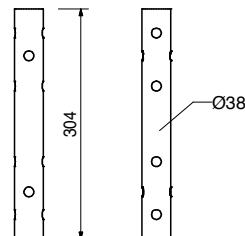

		Accessories
111053	0.059	Locking pin Ø 48/57
100719	0.060	Bolt ISO 4014 M10 x 70-8.8

Article no. Weight kg

132479	3.190
132483	3.960
132488	4.320
132492	5.450
132502	6.590
132505	7.730
132508	10.500
132511	12.900
132515	15.800

- Steel Decks UDG-2**
Steel Deck UDG-2 25 x 50
Steel Deck UDG-2 25 x 67
Steel Deck UDG-2 25 x 75
Steel Deck UDG-2 25 x 100
Steel Deck UDG-2 25 x 125
Steel Deck UDG-2 25 x 150
Steel Deck UDG-2 25 x 200
Steel Deck UDG-2 25 x 250
Steel Deck UDG-2 25 x 300

Length X: 500 - 1,500 with H of 45 mm
 Length X: 2,000 - 2,500 with H of 60 mm
 Length X: 3,000 with H of 70 mm

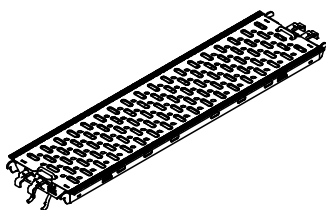

X	perm. p [kN/m ²]
500	6.0
670	6.0
750	6.0
1000	6.0
1250	6.0
1500	6.0
2000	6.0
2500	4.5
3000	3.0

Note
 Values correspond with EN 12811-1

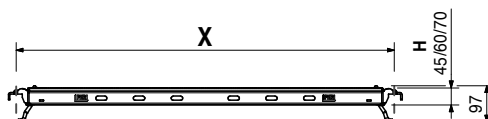

424124	3.880
432858	4.810
424121	5.260
424118	6.630
424115	8.010
424112	9.410
424109	12.200
423771	14.900
424915	17.700

- Steel Decks UDG 25**
Steel Deck UDG 25 x 50
Steel Deck UDG 25 x 67
Steel Deck UDG 25 x 75
Steel Deck UDG 25 x 100
Steel Deck UDG 25 x 125
Steel Deck UDG 25 x 150
Steel Deck UDG 25 x 200
Steel Deck UDG 25 x 250
Steel Deck UDG 25 x 300

Fit onto Horizontal Ledgers UH.

X	perm. p [kN/m ²]	max. p [kN/m ²]
500	6.0	40.0
670	6.0	40.0
750	6.0	40.0
1000	6.0	40.0
1250	6.0	28.4
1500	6.0	19.6
2000	6.0	10.9
2500	4.5	6.9
3000	3.0	4.7

Note
 Values corresponding to EN 12811-1.
 max. p = max. possible surface load without deflection restriction.

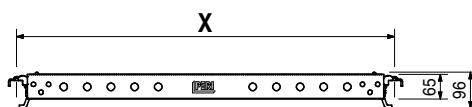
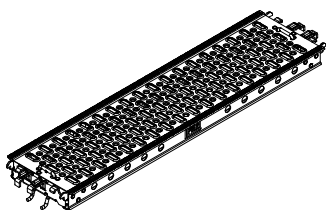

Article no. Weight kg

Article no.	Weight kg		L	X	Y
		Ledger Brace UBL-2			
132771	2.140	Ledger Brace UBL-2 100/50	901	1000	500
132773	2.830	Ledger Brace UBL-2 100/100	1250	1000	1000
132775	3.680	Ledger Brace UBL-2 100/150	1677	1000	1500
132777	4.600	Ledger Brace UBL-2 100/200	2136	1000	2000
132779	3.030	Ledger Brace UBL-2 150/50	1347	1500	500
132781	3.530	Ledger Brace UBL-2 150/100	1601	1500	1000
132783	4.230	Ledger Brace UBL-2 150/150	1953	1500	1500
132785	5.040	Ledger Brace UBL-2 150/200	2358	1500	2000
132787	5.330	Ledger Brace UBL-2 175/200	2500	1750	2000
132789	3.970	Ledger Brace UBL-2 200/50	1820	2000	500
132791	4.360	Ledger Brace UBL-2 200/100	2016	2000	1000
132793	4.940	Ledger Brace UBL-2 200/150	2305	2000	1500
132795	5.640	Ledger Brace UBL-2 200/200	2658	2000	2000
132797	4.450	Ledger Brace UBL-2 225/50	2062	2250	500
132808	4.800	Ledger Brace UBL-2 225/100	2236	2250	1000
132810	5.980	Ledger Brace UBL-2 225/200	2829	2250	2000
132812	5.250	Ledger Brace UBL-2 250/100	2462	2500	1000
132814	5.730	Ledger Brace UBL-2 250/150	2705	2500	1500
132816	6.340	Ledger Brace UBL-2 250/ 200	3010	2500	2000
132827	5.920	Ledger Brace UBL-2 300/50	2795	3000	500
132829	6.180	Ledger Brace UBL-2 300/100	2926	3000	1000
132831	6.590	Ledger Brace UBL-2 300/150	3133	3000	1500
132833	7.120	Ledger Brace UBL-2 300/200	3400	3000	2000

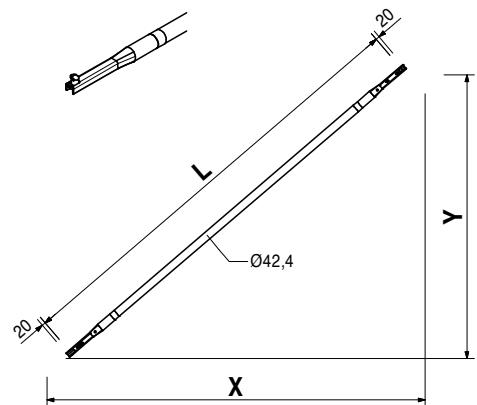
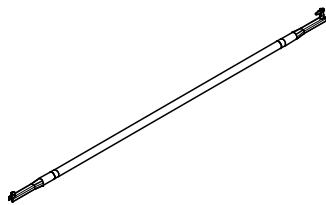

Article no. Weight kg

Article no.	Weight kg		L	X	Y
		Ledger Brace UBL			
415156	2.660	Ledger Brace UBL 100/50	901	1000	500
415513	4.640	Ledger Brace UBL 100/150	1677	1000	1500
415157	5.810	Ledger Brace UBL 100/200	2136	1000	2000
407867	3.790	Ledger Brace UBL 150/50	1347	1500	500
400055	4.440	Ledger Brace UBL 150/100	1601	1500	1000
402846	5.340	Ledger Brace UBL 150/150	1953	1500	1500
400057	6.380	Ledger Brace UBL 150/200	2358	1500	2000
409034	6.740	Ledger Brace UBL 175/200	2500	1750	2000
404391	5.000	Ledger Brace UBL 200/50	1820	2000	500
400059	5.510	Ledger Brace UBL 200/100	2016	2000	1000
402862	6.240	Ledger Brace UBL 200/150	2305	2000	1500
400061	7.150	Ledger Brace UBL 200/200	2658	2000	2000
430282	5.620	Ledger Brace UBL 225/50	2062	2250	500
430283	6.070	Ledger Brace UBL 225/100	2236	2250	1000
417689	7.580	Ledger Brace UBL 225/200	2829	2250	2000
400063	6.640	Ledger Brace UBL 250/100	2462	2500	1000
402861	7.260	Ledger Brace UBL 250/150	2705	2500	1500
400065	8.050	Ledger Brace UBL 250/200	3010	2500	2000
404762	7.490	Ledger Brace UBL 300/50	2795	3000	500
400067	7.830	Ledger Brace UBL 300/100	2926	3000	1000
404766	8.360	Ledger Brace UBL 300/150	3133	3000	1500
400069	9.040	Ledger Brace UBL 300/200	3400	3000	2000

They are attached using holes in the horizontal ledgers.

Note
With length marking for easier identification.

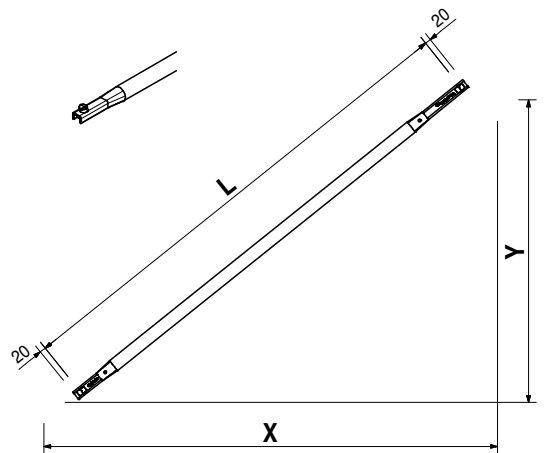
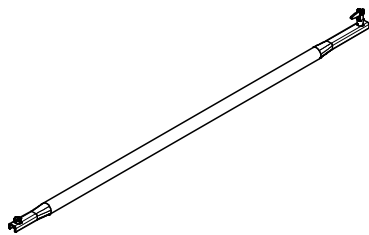

Article no. Weight kg

Article no.	Weight kg		L	X	Y
133418	4.980	Node Brace UBK-2	2190	750	2000
133421	5.130	Node Brace UBK-2 75/200	2285	1000	2000
133424	3.900	Node Brace UBK-2 100/200	1625	1250	1000
133427	5.320	Node Brace UBK-2 125/200	2401	1250	2000
133430	4.240	Node Brace UBK-2 150/100	1821	1500	1000
133433	4.840	Node Brace UBK-2 150/150	2152	1500	1500
133436	5.550	Node Brace UBK-2 150/200	2539	1500	2000
133439	4.990	Node Brace UBK-2 200/100	2246	2000	1000
133442	5.490	Node Brace UBK-2 200/150	2521	2000	1500
133445	6.100	Node Brace UBK-2 200/200	2860	2000	2000
133448	5.790	Node Brace UBK-2 250/100	2696	2500	1000
133451	6.210	Node Brace UBK-2 250/150	2930	2500	1500
133454	6.740	Node Brace UBK-2 250/200	3226	2500	2000
133457	6.620	Node Brace UBK-2 300/100	3131	3000	1000
133460	6.980	Node Brace UBK-2 300/150	3356	3000	1500
133463	7.440	Node Brace UBK-2 300/200	3625	3000	2000

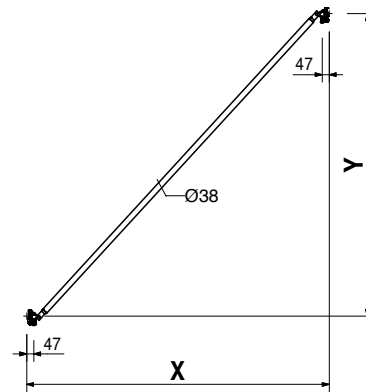
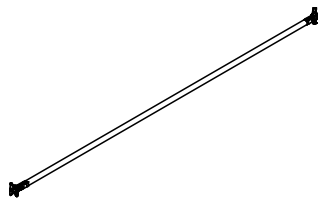

Article no.	Weight kg		L	X	Y
424170	6.770	Node Brace UBK	2190	750	2000
412926	6.980	Node Brace UBK 75/200	2285	1000	2000
415354	5.210	Node Brace UBK 100/200	1625	1250	1000
412765	7.250	Node Brace UBK 125/200	2401	1250	2000
400981	5.700	Node Brace UBK 150/100	1821	1500	1000
400973	6.570	Node Brace UBK 150/150	2152	1500	1500
400572	7.590	Node Brace UBK 150/200	2539	1500	2000
400985	6.780	Node Brace UBK 200/100	2246	2000	1000
406630	7.500	Node Brace UBK 200/150	2521	2000	1500
400573	8.380	Node Brace UBK 200/200	2860	2000	2000
400989	7.930	Node Brace UBK 250/100	2696	2500	1000
406624	8.530	Node Brace UBK 250/150	2930	2500	1500
400574	9.300	Node Brace UBK 250/200	3226	2500	2000
400993	9.120	Node Brace UBK 300/100	3131	3000	1000
400575	10.300	Node Brace UBK 300/200	3625	3000	2000

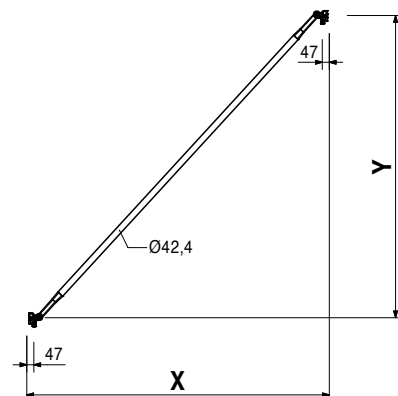
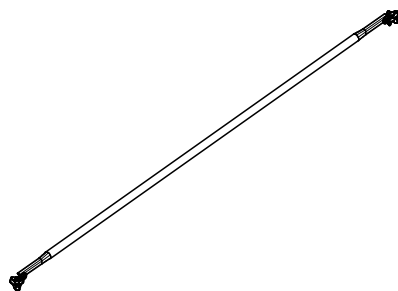

Article no. Weight kg

Article no.	Weight kg		L	X	Y
114912	6.660	Horizontal Brace UBH Flex	2042	1500	1500
124097	7.780	Horizontal Brace UBH Flex 150/150	2422	2000	1500
114916	8.740	Horizontal Brace UBH Flex 200/150	2749	2000	2000
124101	9.000	Horizontal Brace UBH Flex 200/200	2838	2500	1500
114920	9.840	Horizontal Brace UBH Flex 250/150	3123	2500	2000
114928	10.800	Horizontal Brace UBH Flex 250/200	3456	2500	2500
124105	10.300	Horizontal Brace UBH Flex 300/150	3279	3000	1500
114924	11.000	Horizontal Brace UBH Flex 300/200	3528	3000	2000
114932	11.900	Horizontal Brace UBH Flex 300/250	3826	3000	2500
114936	12.900	Horizontal Brace UBH Flex 300/300	4163	3000	3000

For horizontal bracing of towers.
Also for use beneath Decks UDG.

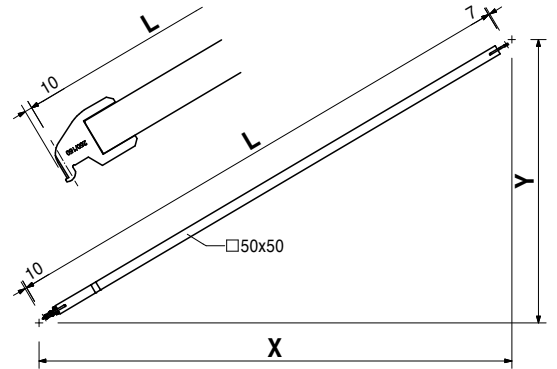
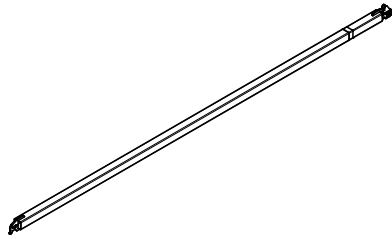

Article no.	Weight kg		L	X	Y
131750	7.330	Coupler Braces UBC-2	1750	670	2000
131726	9.020	Coupler Brace UBC-2 67-100/200	2305	1500	2000
131741	10.100	Coupler Brace UBC-2 150/200	2657	2000	2000
131744	11.300	Coupler Brace UBC-2 200/200	3052	2500	2000
131747	12.500	Coupler Brace UBC-2 300/200	3473	3000	2000

For special applications.
For connecting scaffold tubes Ø 48 mm.

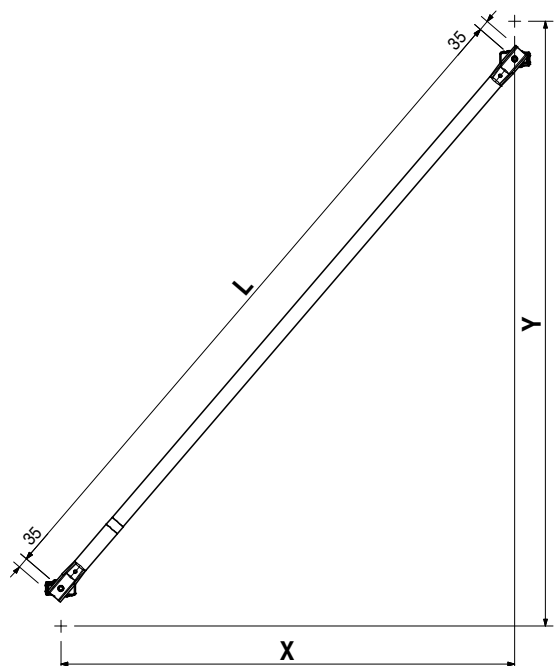
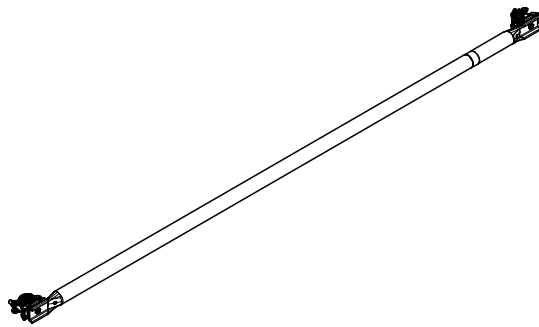

Article no. Weight kg

		Coupler Braces UBC
400416	9.520	Coupler Brace UBC 150/200
400419	10.800	Coupler Brace UBC 200/200
400422	12.200	Coupler Brace UBC 250/200
400425	13.700	Coupler Brace UBC 300/200

For special applications.
For connecting scaffold tubes \varnothing 48 mm.

L	X	Y
2305	1500	2000
2657	2000	2000
3052	2500	2000
3473	3000	2000

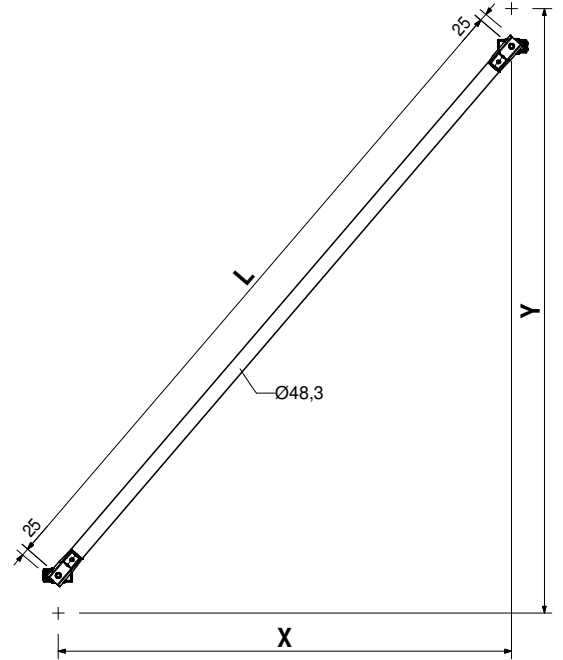
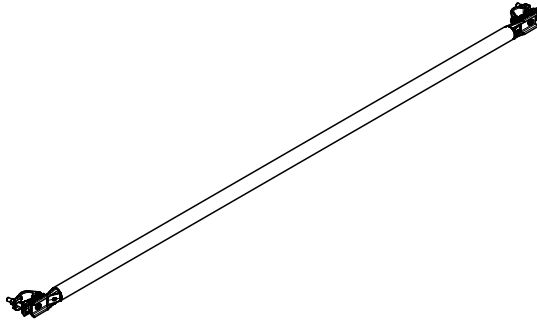

131135	64.900
131329	71.900

Post Pallets ESP
Post Pallet ESP 67
Post Pallet ESP 100

For stacking and transporting max. 20
Easy Standards EVF.

Note
Delivery unit: 6 pieces.

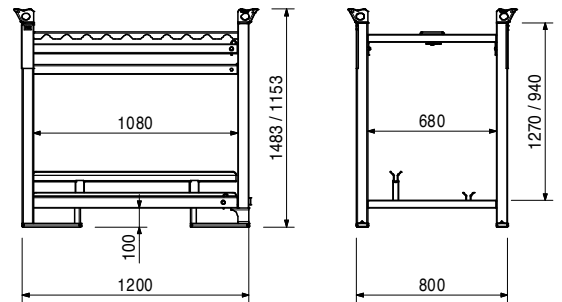
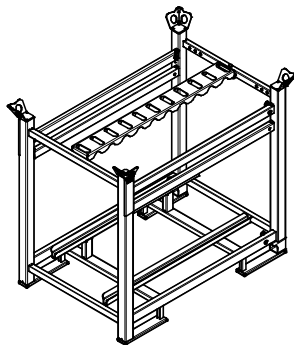

Article no. Weight kg

113832 0.035

PERI UP Scaffold Tag

For cordoning off scaffolding areas not yet authorised for use. With the exception of inserting the PERI UP Assembly Certificates.



113833	0.005
113834	0.005
113829	0.005
113835	0.005
113836	0.005
113837	0.005
113838	0.005
113839	0.005
115739	0.005
115729	0.005

- PERI UP Assembly Certificates**
- PERI UP Assembly Certificate, D**
- PERI UP Assembly Certificate, EX**
- PERI UP Assembly Certificate, F**
- PERI UP Assembly Certificate, CDN**
- PERI UP Assembly Certificate, ES**
- PERI UP Assembly Certificate, PT**
- PERI UP Assembly Certificate, PL**
- PERI UP Assembly Certificate, CZ**
- PERI UP Assembly Certificate, TR**
- PERI UP Assembly Certificate, SK**

Inserted into the PERI UP Scaffold Tag.

Note

Front: Assembly certificate for the approval of scaffolding.
Rear side: Inspection log

Inspection Record
Inspection by qualified person only

Important
Any modifications made to the scaffold, e.g. removal of anchors, may only be carried out by the scaffolder.

Date	Time	Signature

Scaffold is no longer authorized for use:
Date: _____

Assembly Certificate
To be completed by the supervisor

Installation location: _____
Position: _____
Client: _____
Scaffolder: _____
Date: _____
Signature: _____

Working scaffold according to EN 12811, for Load Class

W06
 W12

Width Class W
 W06 0.6 ≤ w ≤ 0.9 m
 W09 0.9 ≤ w ≤ 1.2 m
 W12 W24 w ≥ 1.2 m

Handing-Over Certificate
To be completed by the inspecting person

Name: _____
Signature: _____
Date, Time: _____
Remarks: _____

© 2007 PERI System- & Anlagenbau AG

Article no. Weight kg

133753 9.290

Weather Protection EVW 200-V

Standard on uppermost level in conjunction with Weather Protection EVW 130 or 180. Used together with tarpaulin coverings against the effects of the weather.

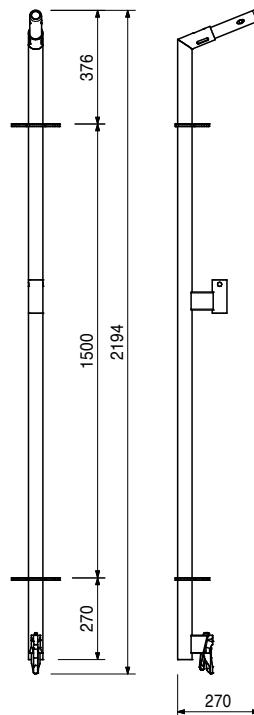
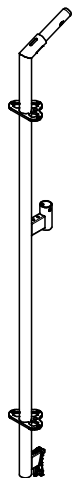

133742

7.200

Weather Protection Legs EVW 180

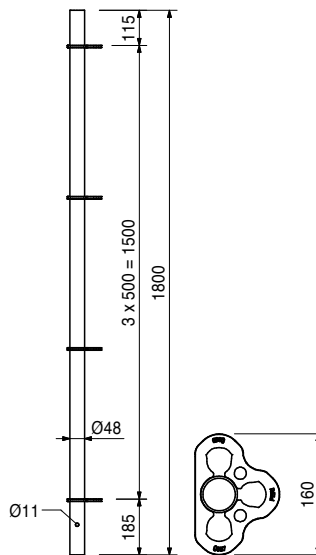
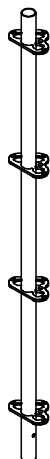

Article no. Weight kg

133743 3.940

Weather Protection Legs EVW 130

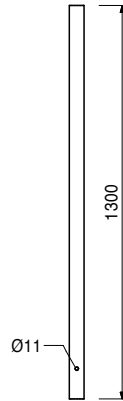

109630 4.240

Spindle Head SRU

For connecting SRU and SRZ steel walers on shoring systems.

Note

With captive quick jack nut.

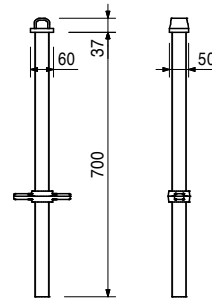
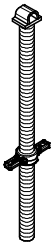

Accessories

104031 0.462

Fitting Pin Ø 21 x 120

018060 0.014

Cotter pin 4/1, galv.

133757 1.200

Coupling EVW

In conjunction with Weather Protection EVW 180.

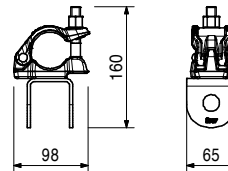

Accessories

104031 0.462

Fitting Pin Ø 21 x 120

018060 0.014

Cotter pin 4/1, galv.

Article no. Weight kg

109563 1.460

Head Spindle Locking UJH

Connects head spindles, section spindles and spindle head with Horizontal Ledgers UH during repositioning.

Complete with

1 pc. 018060 cotter pin 4/1, galv.

Technical data

Permissible load 2.1 kN.

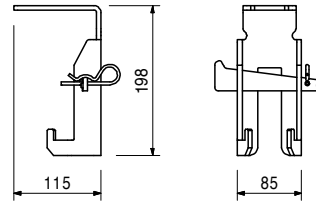
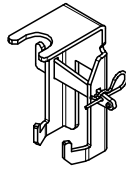

126009

1.630

LGS Keder Connector URV

For fixing Keder Tracks URK to scaffold components with tube Ø 48.3 mm.

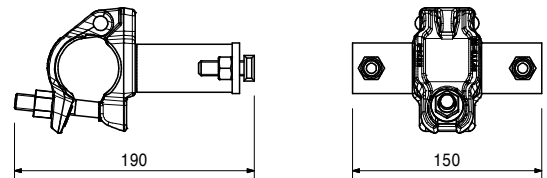
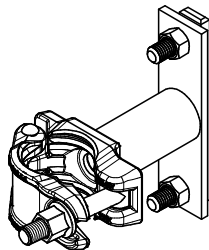

127501

3.530

LGS Keder Tracks URK

127500

7.050

LGS Keder Track URK 150

126071

14.100

LGS Keder Track URK 300

LGS Keder Track URK 600

Track for drawing keder tarpaulins into scaffold constructions.

L

1500

3000

6000

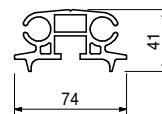
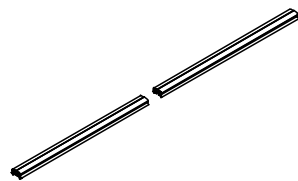

134177

0.186

Spindle Lining UES

The protective underlay for base spindles protects sensitive base decks from damage by the base spindle plate.

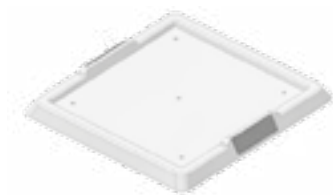

Article no. Weight kg

134175 0.065 **Poly Cover Coupling UPC-C**

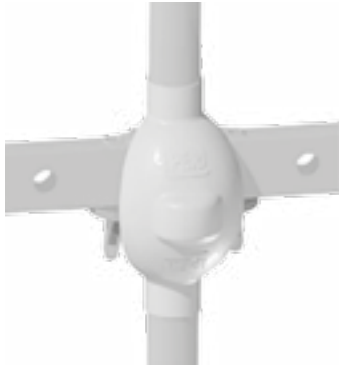

133907 0.015 **Poly Cover Tube UPC-T**



134176 0.098 **Poly Cover Rosette UPC-R**



136832 0.000

Cover Plate UDP 67

Fit onto Horizontal Ledgers UH. Closes deck gaps between scaffold bays in the scaffolding of circular buildings.

Technical data

Load Class 3, 2.0 kN/m²

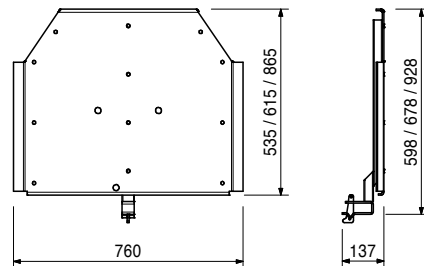
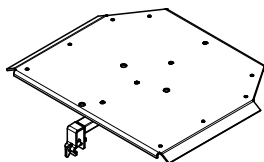

**The optimum system
for every project and
every requirement**



Wall formwork



Column formwork



Slab formwork



Climbing systems



Bridge formwork



Tunnel formwork



Shoring



Working scaffolds



Working scaffolds facade



Working scaffolds industry



Means of access



Safety scaffolds



Safety systems



System-independent accessories



Services



PERI AG
Formwork Scaffolding Engineering
 Rudolf-Diesel-Strasse 19
 89264 Weissenhorn
 Germany
 Telephone +49 (0)7309.950-0
 Fax +49 (0)7309.951-0
 info@peri.com
 www.peri.com

