

PERI UP Scaffolding Kit

Core components

Assembly instructions – Version 2.2

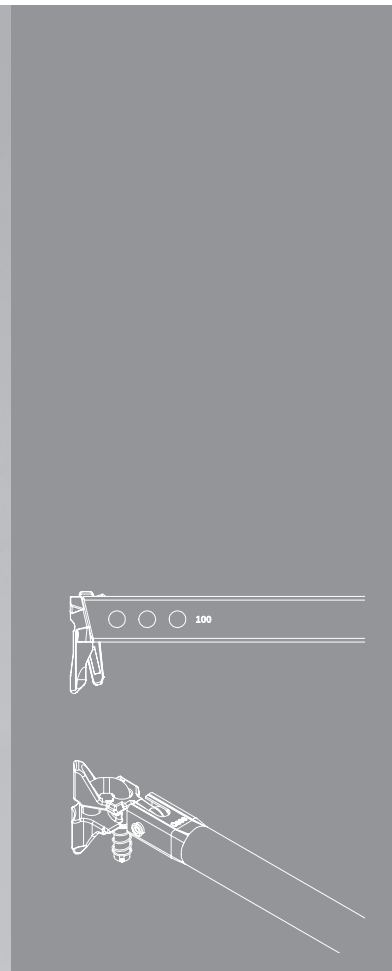
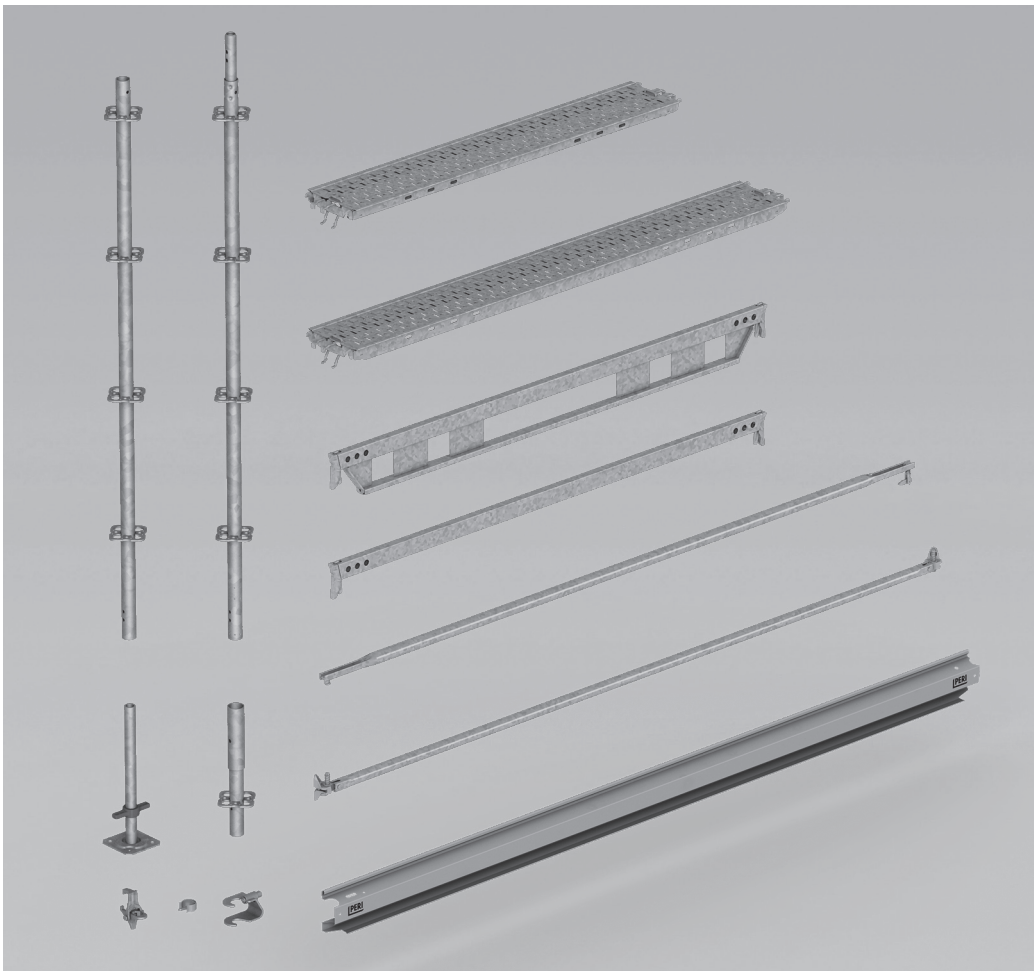

Overview

Components	4
Key	5

Introduction

Target groups	6
Product description	7
Cleaning and maintenance instructions	8
Disposal	8
Information regarding relocation by crane	8
Additional technical documentation	9
Instructions for Use	9

Safety instructions

Cross-system	10
System-specific	12
Reaction forces	12
Checking the anchoring	12
Storage and transportation	12
Identification marking	13
Laws and regulations	13
Inspection, handover and use	14

Safety during assembly

Verified attachment points	15
Attachment points in the system	16
Measures to prevent tipping	17

System components

A1 Spindles and rollers

General	18
Base plate	19
Base spindles	20
Swivel castors and castors	24
Movement by crane	29

A2 Standards

General	32
Base Standard UVB	32
Standards UVR-2	33
Top Standard UVH-2	34
Top Standard EVT 96	34
Hanging verticals used	35
Comparison of components	38

A3 Horizontal ledger

Horizontal ledger	40
Wedge couplings	41
Comparison of components	42

A4 Braces

General	44
Horizontal Brace UBH Flex	45
Node Braces UBK/UBK-2	47
Comparison of components	49
Coupler Brace UBC-2	50
Ledger Brace UBL/UBL-2	51
Comparison of components	54
Shoring Brace UBS	55

A5 Lateral protection

General	56
Toe Board UPY	57
Toe Board Compensation UPY-L	59
Toe Board UPF	60
Guardrail Post EPG	61
Swing Ledger UPK	62
Safety Entry Gate UPS	63
End Guardrail in Advance UPA-2	64

A6 Console Brackets

General	66
Load-bearing capacities	67
Console bracket assembly	68
Console brackets with protection panel posts/guardrail posts	69
Support UC 25/33	71
Support UCS 33	71
Console Bracket ECM	71
Console Bracket UCB 25	73
Console Bracket UCM	73
Console Bracket Brace UCM	74

A7 Decks

General	76
Steel Deck UDG-2	77
Comparison of components	78
Steel Deck EDS	79
Deck Traverse UDT	81
Cover Plate UDB	83
Inside Corner Plate EDP 25 /33	84
Cover Plate UDP	85
Corner Plate UDC	86

A8 Scaffold access

General	88
Access Decks UAA/UAC/UAW	89
Passage Deck UAA/UAC/UAW	90
Passage UAF	91
Stair towers	92
Stair Guardrail UAG	94
Stair Guardrail UAH-2	94

A9 Ladders

General	96
Ladder Connector UAM-W	98
Ladder Connector Ledger UAM-S	99
Ladder UAV	99
Ladder Connector Diagonal UAD	100
Installing the access ladder	100
Ladder Connector UAV 43-C	102
Ladder Connector UAC-2	104
Ladder 180/6	104

A10 Couplings	
General	108
Clamping rosettes	109
Coupling connection for UH 30/60	110
Coupling connection for UH	111
Spacer UEC-2	112
Tension coupler Ø 48.3	113
Tube connector Ø 48.3	113
Flange Coupling UEF	114
A11 Connecting parts	
General	118
Adapter Suspended Scaffold UEH	119
Guardrail Holder EPW	121
Guardrail Coupling EPR	122
Ledger-to-Ledger Coupler UHA	123
Ledger-to-Ledger Coupler UHA-2	124
Ledger-to-Ledger Coupler UHA half	125
UH Spigot-2	126
Ledger-to-Ledger Coupler UHA-2 Half with Spigot	128
Connector ULT	131
Pin with Spacer Tube URE 4/42	132
A12 Anchoring	
General	134
Eyebolt UFE	134
Wall Tie UWT	136
A13 Bridging	
Multi Girder ELM 200	138
Formwork Girder ULA/ULS	140
Formwork Girder ULS Flex	141
A14 Weather protection	
LGS Keder Track URK	144
LGS Keder Connector URV	144
A15 Scaffolding support	
Multi Brace EWB	146
Bracing	150
Push-Pull Props RS	152
A16 Polycover Protective Parts	
General	154
Poly Cover Tubes UPC-T	154
Poly Cover Rosette UPC-R	154
Poly Cover Couplings UPC-C	155
Spindle Lining UES	156
Program overview	
Program overview	158

Components

Pos. no.	Designation	Art. no.
1	Base Plate UJP	100244
2	Base Spindle UJB 38-36/17	116762
3	Base Spindle TR 38-70/50	019780
4	Pivoting Base Spindle UJS 38-80/50	100159
5	Castor UEW 30 with spindle	123941
6	Castor UEW 12 with pin, galv.	101858
7	Castor UEW 12 with spindle, galv.	101860
9	Spindle Locking UJS	100863
10	Locking pin Ø 48/57	111053
11	Base Standard UVB 25	133499
12	Standard UVR-2 50	132219
13	Top Standard UVH-2 50	132123
14	Horizontal Ledger UH-2	131995
15	Horizontal Ledger UHV-2	137020
17	Top Standard EVT 96	135972
20	Horizontal Braces UBH Flex	114818
21	Node Brace UBK-2	133418
22	Coupler Brace UBC-2	131750
23	Ledger Braces UBL-2	132771
24	Shoring Brace UBS	128936
30	Steel Toe Board UPY	132592
31	Toe Board Compensation UPYL	134542
32	Wood Toe Board UPF	129490
33	Guardrail Post EPG	130193
34	Swing Ledger UPK 100	416695
35	Safety Entry Gate UPS	125672
36	End Guardrail in Advance UPA-2	134102
37	Protection Panel Post EPS	130532
40	Support UC 25	115959
41	Console Bracket ECM 100	130365
42	Console Bracket UCB 25	134005
43	Console Bracket UCM 50 with semi-rosette	112690
44	Console Bracket UCM 50 with spigot	412676
45	Console Bracket UCM 50-2	110483
46	Bracket Brace UCM	112717
47	Support UCS 33	136048
50	Steel Deck UDG-2 25 X 50	132479
51	Inside Corner Plate EDP 25	134549
52	Cover Plate UDP 100	112809
53	Corner Plate UDC 100	113358
55	Steel Deck EDS 33 x 300	129272
60	Access Deck UAA 75x250-L	133314
61	Passage Deck UAA 75x150	132993
62	Ladder UAF 200	109879
63	Passage UAF 50 x 75	109783
69	Ladder Connector UAC-2	124813
70	Ladder Connector UAV 43-C	133312
71	Ladder Connector Ledger UAM-S	134520
72	Ladder Connector Ledger UAM-W	134527
73	Ladder Connector Diagonal UAD	134512
74	Vertical Ladder UAV 43 x 91	133310
75	Ladder Aluminium UAI 300-A	135529
76	Ladder 180/6	051410
77	Ladder base	051460
78	Ladder safety cage 75/150	104132
79	Flex Stair UAS-2 75x300x200	134561

Pos. no.	Designation	Art. no.
80	Clamping Rosette UEV 180 °	116306
81	Coupling connection for UH 30/60	137211
82	Coupling connection for UH	105824
83	Spacer UEC-2	133739
84	Tension coupler Ø 48.3 mm, galv.	100908
85	Tube connector Ø 48.3 mm, galv.	100909
86	Flange Coupling UEF	134204
90	Adapter Suspended Scaffold UEH	134108
91	Guardrail Holder EPW	130562
92	Guardrail Coupling EPR	130434
93	Ledger-to-Ledger Coupler UHA	101731
94	Ledger-to-Ledger Coupler UHA-2	136582
95	Ledger-to-Ledger Coupler UHA half	110793
96	UH SPIGOT-2	130681
97	Ledger-To-Ledger Coupler UHA-2 half with spigot	130684
98	Connector ULT 32	100301
99	Pin w. Spacer Tube URE 4/42	105372
100	Eyebolt UFE 12/90	100693
101	Expanding dowel 14/70	100696
102	Wall Tie UWT 45	100088
110	Multi Girder ELM	131368
111	Formwork Girder Alu ULA 50/425 HD	101656
112	Formwork Girder Steel ULS 50/425	100330
113	Intermediate Element ULS 100 Flex	124795
114	End Element ULS 50 Flex	124805
115	Connector ULS FLEX	124806
116	Flange Coupling UEC	413726
120	Coupling EVW	133757
121	LGS Keder Connector URV	126009
122	LGS Keder Track URK 150	127501
134	Scaffold support, coated	131092
135	Multi Brace EWB	131093
136	Base plate for EWB	131097
137	Tie Bolt PERI 14/20 x 130	124777
140	Poly Cover Couplings UPC-C	134175
141	Poly Cover Tubes UPC-T	133907
142	Poly Cover Rosette UPC-R	134176
143	Spindle Lining UES	134177
145	Steel scaffolding tube Ø 48.3 x 3.2	026415
146	Brace Connector HDR-2	131723
147	Push-Pull Prop RS 650	117468
148	Bolt Ø 20 x 140, galv.	105400
149	Cotter Pin 4/1, galv.	018060
160	Stair Guardrail UAG	100742
161	Stair Guardrail UAH-2	133543
165	Deck Traverse UDT 25	136786
166	Cover Plate UDB 20x100	136927
167	FLRD screw M 10x60 DIN 603-8.8VZ	137252
168	SKT-MU ISO 4032 M10-8-VZ-SW17	137279



Article numbers beginning with the number 3 or 4 are only available as rental articles or used.

Key

Pictogram | Definition

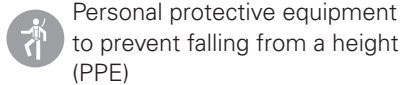
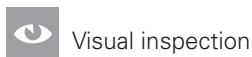
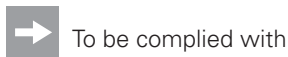

Arrows

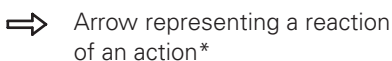

* If not identical to the action arrow.

Safety instruction categories

The safety instructions alert site personnel to the risks involved and provide information on how to avoid these risks. Safety instructions can be found at the beginning of the section or before instructions for action and are highlighted as follows:



This sign indicates an extremely hazardous situation which could result in death or serious, irreversible injury if the safety instructions are not followed.



This sign indicates a hazardous situation which could result in death or serious, irreversible injury if the safety instructions are not followed.



This sign indicates a hazardous situation which could result in minor or moderate injury if the safety instructions are not followed.



This sign indicates situations in which failure to observe the information can result in material damage.

Format of the safety instructions



Type and source of hazard!
Consequences of non-compliance.
Preventative measures.

Dimensions

Dimensions are usually given in cm. Other measurement units, e.g. m, are shown in the illustrations.

Conventions

Instructions are numbered with:
1., 2., 3.

The result of an instruction is shown by: →

Position numbers are clearly provided for the individual components and are given in the drawing, e.g. **1**, in the text in brackets, for example **(1)**.

Multiple position numbers, i.e. alternative components, are represented with a slash: e.g. **1/2**.

Notes on illustrations

The illustration on the front cover of these instructions is understood to be a system representation only. The assembly steps presented in these Assembly Instructions are shown in the form of examples with only one component size. They are valid for all component sizes contained in the standard configuration.

To facilitate understanding, illustrations are sometimes incomplete. Any safety equipments that are not shown in these illustrations must be incorporated nonetheless.

Terminology

Components are not always named in full so that they are easier to read. All components deemed valid according to the program overview may be used. Exceptions are specified.

Example:

- Horizontal ledger
- equally valid:
- Horizontal Ledger UH Plus
- Horizontal Ledger UH-2

Target groups

Scaffolding contractors/contractors

These assembly instructions are intended for contractors who either

- assemble, modify and dismantle the scaffolds, or
- use them, e.g. for pouring concrete, or
- allow them to be used for other operations, e.g. carpentry or electrical work.

Safety and Health Protection Coordinator*

- is appointed by the client,
- must identify potential hazards during the planning phase,
- determines measures that provide protection against risks,
- creates a safety and health protection plan,
- coordinates the protective measures for the contractor and site personnel so that they do not endanger each other,
- monitors compliance with the protective measures.

Competent person

- is appointed by the scaffolding contractor,
- must be on site for all scaffolding work,
- prepares and updates the plan for assembly, modification and dismantling,
- prepares and updates the plan for use of the scaffold by the scaffold user,
- supervises the assembly, modification and dismantling work (supervisor).

Competent persons qualified to carry out inspections

Due to the specialist knowledge gained from professional training, work experience and recent professional activity, the competent person qualified to carry out inspections has a reliable understanding of safety-related issues and can carry out inspections correctly. Depending on the complexity of the inspection to be undertaken, e.g. scope of testing, type of testing or the use of certain measuring devices, a range of specialist knowledge is necessary.

Qualified personnel

Scaffolds may only be assembled, modified or dismantled by personnel who are suitably qualified to do so. Qualified personnel must have completed a course of training** in the work to be performed, covering the following points at least:

- Explanation of the plan for the assembly, modification or dismantling of the scaffold in an understandable form and language.
- Description of the measures for safely assembling, modifying or dismantling the scaffold.
- Naming of the preventive measures to be taken to avoid the risk of persons and objects falling.

- Designation of the safety precautions in the event of changing weather conditions that could adversely affect the safety of the scaffold, as well as the personnel concerned.
- Details regarding permissible loads.
- Description of all other risks and dangers associated with assembly, modification or dismantling operations.



- **In other countries, ensure that the relevant national guidelines and regulations in the respective current version are complied with!**
- **If no country-specific regulations are available, it is recommended to proceed according to German guidelines and regulations.**

* Valid in Germany: Regulations for Occupational Health and Safety on Construction Sites 30 (RAB 30).

** Instructions are given by the contractor themselves or a competent person selected by them.

Product description

Purpose of these assembly instructions

These Assembly Instructions provide a basic description of the assembly of the PERI UP system scaffolding components. Typical standard set-ups are described in separate Instructions for Assembly and Use, see "Additional technical documentation".

The Assembly Instructions may only be used in combination with the associated application verification.

These Assembly Instructions are based on the scaffolding system approvals "PERI UP Flex Z-8.22-863" and "PERI UP Easy Z-8.1-957". They describe the assembly of the components of the PERI UP Scaffolding Kit, regardless of the application in which the components are used.

The application verification describes the special requirements of the application.

It contains:

- the permissible loads,
- static proof,
- drawings,
- a parts list.

The application verification must be created by the contractor personally. PERI offers the following assistance:

- Instructions for Assembly and Use for PERI UP Flex and PERI UP Easy,
- PERI UP Design Tables,
- already created documents, e.g. trench bridge application verification,
- support for project-specific requirements.

The assembly instructions together with the proof of use are equivalent to Instructions for Assembly and Use.

Features

The structure is based on the components of the scaffolding kit.

The permissible loads are to be determined and verified on a project-specific basis. These are shown in the where-used list.

The transfer of vertical and horizontal forces from e.g. dead, live, wind and bracing loads into the supporting structure or the building must be verified separately in each individual case.

Intended use

PERI products have been designed for exclusive use in the industrial and commercial sectors only by suitably trained personnel.

Cleaning and maintenance instructions

Clean the scaffolding components after each use to maintain the value and operational readiness of the PERI products over the long term.

Some repair work may also be inevitable due to the tough working conditions.



The contractor must ensure that the personal protective equipment required for cleaning, maintenance and repair work such as

- safety helmet,
- safety shoes,
- safety gloves,
- safety goggles,

is available and used as intended.

The following instructions should help to keep cleaning and maintenance costs as low as possible.

Cleaning tools must be adapted to the respective surfaces of the components so that they are not damaged.

Mechanical components, e.g. spindles, must be cleaned of dirt or concrete residue before and after use, and then greased with a suitable lubricant.

Do not use plastic components if fibre reinforcements are exposed.

Provide suitable support for the components during cleaning so that no unintentional change in their position is possible.

Do not clean components suspended on crane lifting gear.

Components with wood parts are to be stored in well-ventilated and dry conditions.

Any repairs to PERI products are to be carried out by PERI qualified personnel only.

Disposal

Dispose of in accordance with the relevant national regulations.

Information regarding relocation by crane

The PERI UP scaffolding system is also suitable for hoisting operations involving cranes.

However, the displacement of the scaffold is not part of these assembly instructions.

The appropriate attachment points and the size of the relocation units should always be calculated on a project-specific basis.

Only vertical crane transportation is permitted. Do not assemble scaffolds horizontally and then erect them. Exceptions are described in the applicable Instructions for Assembly and Use.

Before moving the crane, it must always be ensured that:

- all base spindle locks have been fitted,
- all vertical joints are securely connected to one another,
- all deck levels have additional bracing using horizontal ledgers,
- all wedges have been securely fixed in place using a hammer,
- all locks against lifting are engaged,
- all guardrails are at their end position,
- In strong winds, the Toe Boards UPY and the Toe Boards UPF must be additionally secured.
- Do not stand under suspended loads, guide the scaffold with ropes.

Additional technical documentation

- Approvals
 - Approval Z-8.22-863 PERI UP Flex module system
 - Approval Z-8.1-957 PERI UP Easy module system
- Design Tables
 - PERI UP Design Tables
- PI Sheet
 - PI 550 Formwork Girder ULS Flex – permissible load
- User information
 - Pallets and stacking devices
- Brochures
 - PERI UP Flex Working Platforms
 - PERI UP Access Technology for construction sites, industry and the public sector
- Instructions for Assembly and Use
 - PERI UP Flex Facade Scaffold 75 and 100
 - PERI UP Flex Reinforcement Scaffold 75 and 100 with stair tower
 - PERI UP Flex Stair 75
 - PERI UP Flex Stair 100 and 125
 - PERI UP Flex Weather Protection Roof LGS 75
 - PERI UP Flex Weather Protection Roof LGS 150
 - PERI UP Flex Shoring Tower
 - PERI UP Flex Shoring Tower MDS K
 - PERI UP Flex Heavy-Duty Prop HD
 - PERI UP Flex suspended scaffold
 - PERI UP Flex Trench Bridge
 - PERI UP Flex Working Platform LGS 150
 - PERI UP Easy Facade Scaffold 67 and 100 vertical variant
 - PERI UP Easy Facade Scaffold 67 and 100 frame variant
 - PERI UP Scaffolding Kit Reinforcement Scaffold 75 and 100 with stair tower

Instructions for Use

Use in a manner not intended according to the applicable Instructions for Assembly and Use or deviations from the standard configuration or intended use represent an application with a safety risk, e.g. risk of falling.

Deviations from the standard configuration must be verified for the application by means of separate strength and stability calculations (Industrial Safety Regulation Appendix 1, No. 3.2.1) and explicitly reflected in the assembly instructions.

Only PERI original components may be used.
The use of other products and spare parts is not allowed.
Changes to PERI components are not permitted.

The components described in these assembly instructions may be patent-protected.

Cross-system



Safety instructions apply to all service life phases of the system.

General

The contractor must guarantee that the Instructions for Assembly and Use supplied by PERI are available at all times and understood by the site personnel.

These assembly instructions can be used as the basis for preparing the risk assessment. The risk assessment is compiled by the contractor. The assembly instructions do not replace the risk assessment!

Observe and comply with the safety instructions and permissible loads.

For the application and inspection of PERI products, the current safety regulations and guidelines valid in the respective countries must be observed.

Materials and working areas are to be inspected before each use and assembly for:

- damage,
- stability and
- functional correctness.

Damaged components must be exchanged immediately on site and may no longer be used.

Safety components are to be removed only when they are no longer required.

When on slab formwork, scaffolds and working platforms:

- do not jump,
- do not run,
- do not drop anything from or onto it.

Components provided by the contractor must comply with the characteristics stipulated in these Instructions for Assembly and Use and all applicable laws and standards. Unless otherwise indicated, the following applies in particular:

- Timber components: strength class C24 for solid wood according to EN 338.
- Scaffolding tubes: galvanised steel tubing with minimum dimensions of $\varnothing 48.3 \times 3.2$ mm according to EN 12811-1:2003 4.2.1.2.
- Scaffolding tube couplings according to EN 74-1 and EN 74-2.

Deviations from the standard configuration are only permitted after a further risk assessment has been carried out by the contractor.

Appropriate measures for working and operational safety, as well as stability, are defined on the basis of this risk assessment.

Corresponding proof of stability can be provided by PERI on request, if the risk assessment and resulting measures to be implemented are made available.

Before and after exceptional occurrences that may have an adverse effect on the safety of the scaffolding system, the contractor must immediately

- produce another risk assessment and make use of its results to take suitable steps to guarantee the stability of the scaffolding system,
- arrange for an extraordinary inspection to be carried out by a competent person qualified to do so. The aim of this inspection is to identify and rectify any damage in good time in order to guarantee safe use of the scaffolding system.

Exceptional events could be:

- accidents,
- long periods of non-use,
- natural events, e.g. heavy rainfall, icing, heavy snowfall, storms or earthquakes.

Assembly, modification and dismantling work

Assembly, modification or dismantling of scaffolding systems may only be carried out by qualified persons under the supervision of a competent person. The qualified personnel must have received appropriate training for the work to be carried out with regard to specific risks and dangers.

On the basis of the risk assessment and the applicable Instructions for Assembly and Use, the contractor must draw up assembly instructions to guarantee safe assembly, modification and dismantling of the scaffolding system.

Before initial use, the safe functioning of the scaffold must be checked by a person qualified to carry out the inspection. The results of the inspection must be documented in an inspection log.



The contractor must ensure that the personal protective equipment required for the assembly, modification or dismantling of the scaffolding system, e.g.

- safety helmet,
- safety shoes,
- safety gloves,
- safety goggles,

is available and used as intended.

Comply with the respective assembly descriptions and safety instructions when making modifications or additions to the scaffold.



If personal protective equipment against falling from a height (PPE) is required or specified in local regulations, the contractor must determine appropriate attachment points on the basis of the risk assessment.

The PPE to be used to prevent falling is determined by the contractor.

For technically possible attachment points, see Section “Verified attachment points” on page 15 ff.

The contractor must

- provide safe working areas for site personnel, which are to be reached through the provision of safe access ways. cordon off and clearly mark danger zones.
- guarantee stability during all stages of construction, in particular during assembly, modification and dismantling operations.
- ensure and demonstrate that all loads that occur are safely transferred.

Use

Every contractor who uses or allows the scaffolding systems to be used, is responsible for ensuring that the equipment is in good condition.

If the scaffolding system is used successively or at the same time by several contractors, the health and safety coordinator must point out any possible mutual hazards and all work must then be coordinated.

When scaffolds are used in publicly accessible areas,

- measures to prevent unauthorised use, e.g. enclosure of access areas, must be taken.
- Take measures to prevent injuries caused by impacts with protruding components, e.g. assembly of protective components.

Always keep the contact surfaces of the scaffold free of dirt, objects, snow and ice.

Close off the scaffold in extreme weather conditions.

System-specific

The load-distributing support used, such as planking, must match the respective substrate. If multiple layers are required, planks are to be arranged crosswise.

It must be ensured that the scaffold cannot shift in a horizontal direction, irrespective of what substrate is being used.

Close hatches immediately after use.

Couplings with screw closures must be tightened with 50 Nm. This corresponds to a force of 20 kg using a lever arm length of 25 cm.

Secure the wedges with a jarring blow using a 500 g hammer.

Reaction forces

The anchoring forces, the position of the anchoring and the support reactions can be found in the corresponding tables in the respective Instructions for Assembly and Use.

The enclosure of the scaffold or mounting of additional surfaces exposed to the wind changes the stability and must be calculated separately. If necessary, additional measures must be implemented.

Anchoring must be installed progressively with the erection of the scaffold assembly.

The anchoring forces must be transferred into sufficiently load-bearing anchorage via wall ties and fixing materials e.g. the building.

Checking the anchoring

The anchoring and its components must be inspected by a qualified person nominated by the scaffolding contractor.

Load tests must be carried out at the place of use.

Load tests are to be carried out using suitable test equipment.

The test load must be 1.2 times higher than the required anchoring force F_A .

The scope of testing must, however, include a minimum of 5 load tests for all dowels used for concrete anchoring bases (at least 10 %) and for other building materials (at least 30 %).



Ensure that the relevant national guidelines and regulations are complied with!

Storage and transportation

Store and transport components in such a way that no unintentional change in their position is possible. Detach lifting accessories and gear from the lowered components only if they are in a stable position and no unintentional change is possible.

Do not drop the components.

Use PERI lifting accessories and slings and only those load-bearing points provided on the component.

During the moving procedure:

- ensure that components are picked up and set down in such a way that unintentional falling over, falling apart, sliding, falling down or rolling is avoided.
- no one is allowed to remain under the suspended load.

Always guide pre-assembled scaffolding bays, scaffolding units or scaffolding sections with ropes when moving them by crane.

The access areas on the construction site must be free of obstacles and tripping hazards and must also be slip-resistant.

For transportation, the substrate must have sufficient load-bearing capacity.

Use original PERI storage and transport systems, e.g. crate pallets, pallets or stacking devices.

Inspection, handover and use

The erected scaffold must be inspected by the scaffolding contractor in order to determine that assembly has been carried out correctly. If the contractor is convinced that the scaffold has been correctly erected, it can then be handed over to the user.

It is advisable to carry out the handover with the user and, for example, to document this in a written report.



During the handover, the scaffolding contractor must advise the user of any possible risks involved with non-intended use and his obligation to provide adequate prevention against risk and danger!

- Put up safety and warning signs at the scaffold access point.
- Handover of a usage plan.



The contractor who uses the scaffolds, must ensure that the scaffolds are in good condition and not arbitrarily altered in any way. In this respect, the qualified specialists must be instructed that if changes have obviously been made during use, these must be reported to the respective qualified and competent person.

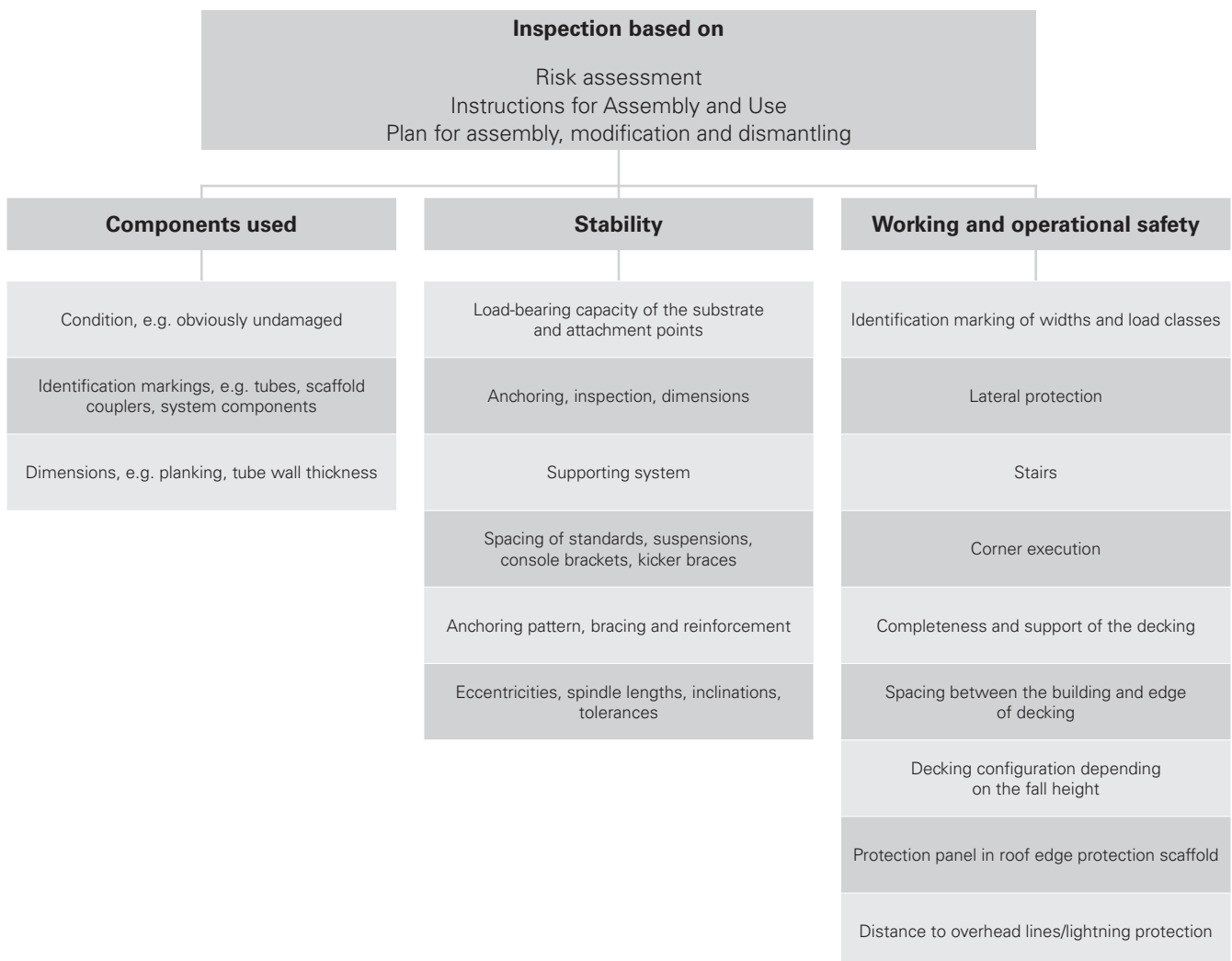

Source: based on TRBS 2121 Part 1

Verified attachment points

Certain assembly situations could occur that require the use of personal protective equipment (PPE) to prevent falling from a height. For this, the following verified attachment points must be used:

All attachment points require the following:

- The standing height can be a maximum of one level above the last anchoring position.
- At least one anchoring layer must always be present, or the scaffold is verified to be free-standing and the tilt resistance is guaranteed.

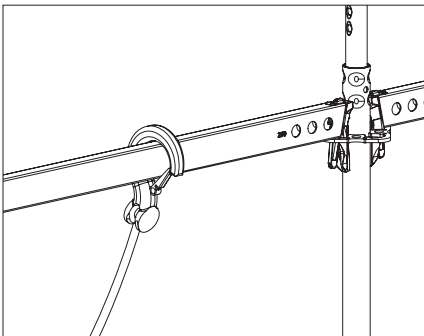

Fig. M.01

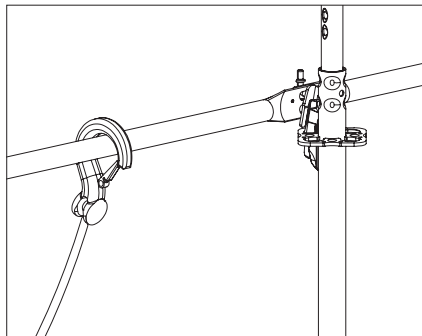

Fig. M.02

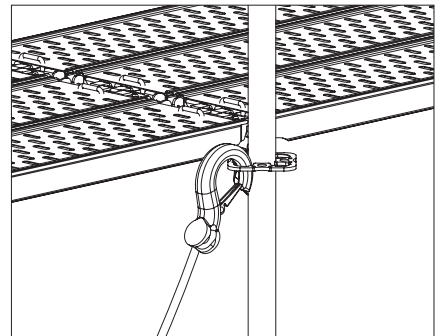

Fig. M.03

Horizontal ledger

Attachment point:

Each Horizontal Ledger UH Plus or UH-2

- which is freely accessible for the lifting gear
- and is installed at a maximum height of 1.0 m above the deck level.
- and which is wedged on two rosettes of 2 standards.
The standards must be at least 2 m long.

Guardrail post

Attachment point:

Each Guardrail Post EPG or intermediate guardrail,

- which is installed at a maximum height of 1.0 m above the deck level.
- and which is installed with 2 Guardrail Holders EPW on two rosettes of 2 standards.
The standards must be at least 2 m long.
- and both the guardrail and the intermediate guardrail are installed.

Rosette

Attachment point:

Each rosette that is integrated in the base scaffold. See rules and regulations on the right.

Attachment points in the system



- Each specified attachment point is intended for securing only one person!

General information

- The use of personal protective equipment to prevent falling from a height is regulated in the project-related risk assessment that has been prepared by the contractor (user).
- When using personal protective equipment to prevent falling from a height, all valid standards and safety regulations are to be taken into consideration by the contractor.
- Each scaffold assembly is to be secured against tipping by the user.
- The application concerns assembly, reconstruction and dismantling.
- The specified heights for permissible attachment points apply only in relation to the component. The respective employer risk assessment regulates the attachment points to be used for the person.

Requirements

- The scaffold assembly underneath the final assembly level is complete. This means, all ledgers and diagonal bracing have been installed and the decking is in place as the topmost assembly level.
- The joints of the topmost standards must lie underneath the last assembly level.

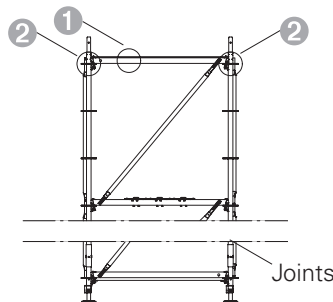

Fig. M.04

Attachment points

Standard ends approx. 2 m below the assembly level:

- each horizontal ledger in the assembly level ①,
- each rosette in the assembly level ②

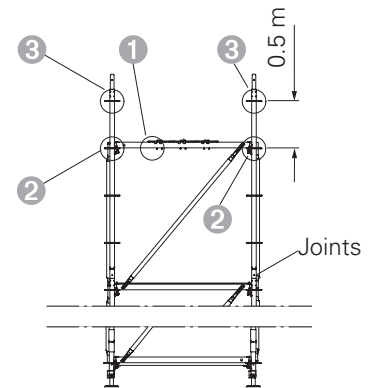

Fig. M.05

Attachment points

Standard ends approx. 1.5 m below the assembly level:

- each horizontal ledger in the assembly level ①,
- each rosette up to max. 0.5 m above the last assembly level ②, ③.

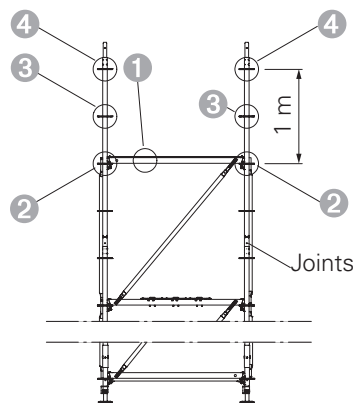

Fig. M.06

Attachment points

Standard ends approx. 1 m below the assembly level:

- each horizontal ledger in the assembly level ①,
- each rosette up to max. 1.0 m above the last assembly level ② ③ ④.

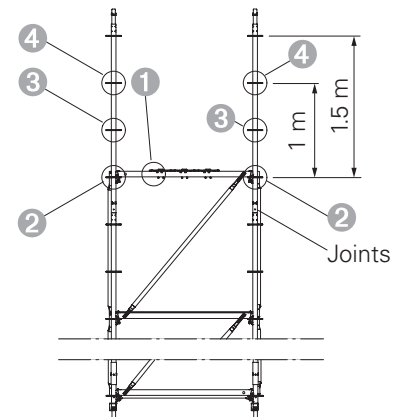

Fig. M.07

Attachment points

Standard ends approx. 0.5 m below the assembly level:

- each horizontal ledger in the assembly level ①,
- each rosette up to max. 1.0 m above the last assembly level ② ③ ④.

Measures to prevent tipping



Warning

A person who is supported by PPE during a fall can cause a scaffolding system to topple over! This can result in serious injuries or even death.

- ⇒ Proof of stability is required!
Ensure the stability of the superstructure for arresting falls.
- ⇒ Anchoring the superstructure to a suitable structure, e.g. building, abutment, supports.
- ⇒ Connecting the scaffold assembly by means of horizontal ledgers; alternatively, with scaffolding tubes and couplers. (Fig. M.08)
- ⇒ Connecting the superstructure with other system components (Fig. M.08) or widening the base (Fig. M.09) to form stable units.
- ⇒ For information on supporting the superstructure see Section "A15 Scaffolding support" on page 146 ff.

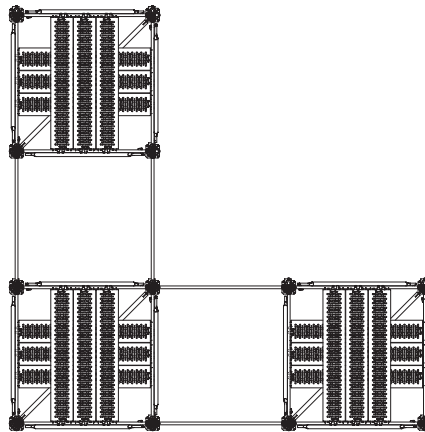
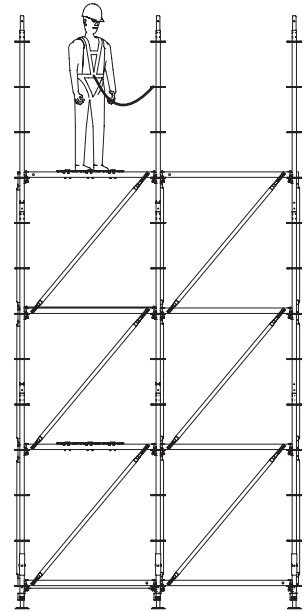
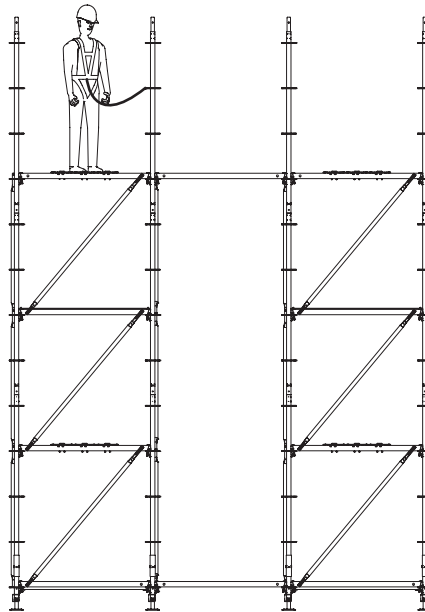

Fig. M.08

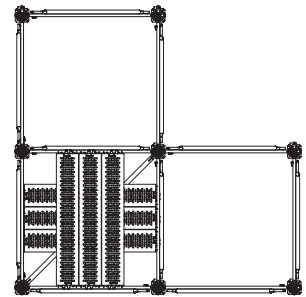

Fig. M.09

General



Note

Stability compromised!

⇒ Settlements must be avoided!

The scaffold may only be erected on a sufficiently load-bearing substrate, if necessary with load-distributing pads. For support forces, see the respective Instructions for Assembly and Use.

⇒ Observe the maximum spindle extension! For each load class and equipment variation, refer to the respective Instructions for Assembly and Use or the assembly plan for the permitted maximum spindle extensions.

⇒ Quick jack nuts of base spindles are secured by a pinch on the threaded rod to prevent them from spinning out too far.

- The remaining spindle, above the stop of the quick jack nut, must be completely in the vertical.
- Do not force the quick jack nuts up beyond the pinch.

⇒ Ensure the scaffold cannot shift horizontally on any substrate.

Components

- 1 Base Plate UJP
- 2a Base Spindle UJB 38-36/17
- 2b Base Spindle UJB 38-50/30
- 2c Base Spindle UJB 38-80/55
- 3 Base Spindle TR 38-70/50
- 4 Pivoting Base Spindle UJS 38-80/50
- 5 Castor UEW 30 with spindle
- 6 Swivel Castor UEW 12 with spindle
- 7 Swivel Castor UEW 12 with pin
- 9 Spindle Locking UJS
- 10 Locking Pin D48/D57

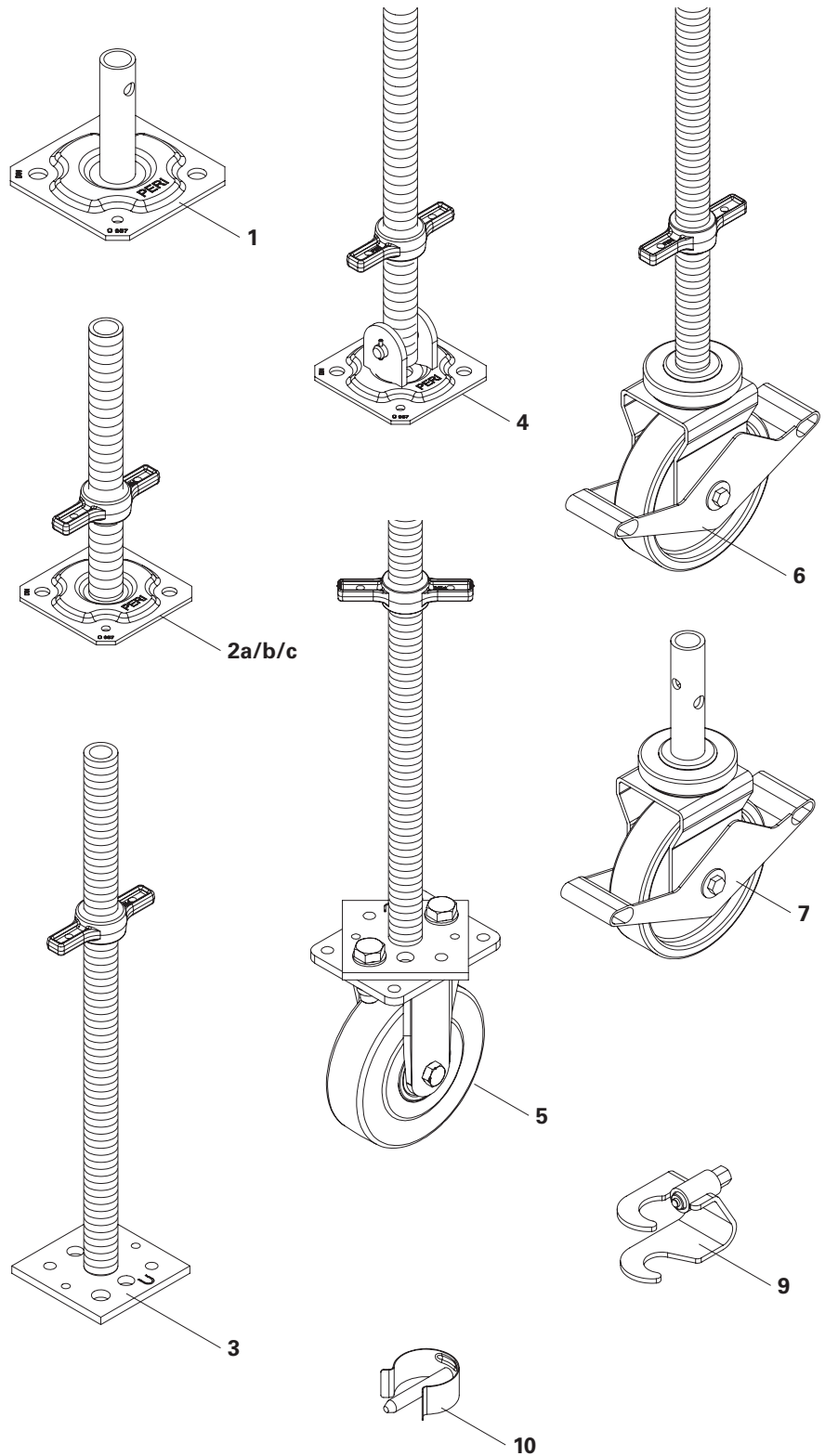
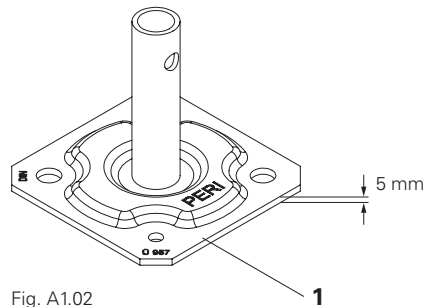

Fig. A1.01

Base plate

Base Plate UJP

- No adjustment travel.
- With stake-out hole for connection to a standard.
- Only use the base plate on a level substrate. Precisely compensate for any differences in height by using suitable supports.



Application example

Very low scaffolds where collisions between head and base spindles would occur, e.g. in bridge hollow boxes.

Technical data

Panel height 5 mm.

Assume support points of base plates as joint according to EN 74.



The Base Plate UJP is not included in type-tested superstructures (e.g. shoring scaffolds) and must be verified on a project-specific basis.

Base spindles

Base Spindle UJB

Base Spindle TR

Components

2a Base Spindle UJB 38-36/17

2b Base Spindle UJB 38-50/30

2c Base Spindle UJB 38-80/55

3 Base Spindle TR 38-70/50

Note

Observe the maximum spindling lengths of the various spindles!
See table A1.01.

⇒ Base Spindles UJB (**2**) must be immersed at least 15 cm in the vertical above.

Base Spindles TR (**3**) must be immersed at least 17.5 cm in the vertical above.

⇒ The quick jack nut is secured by a pinch on the threaded rod to prevent it from spinning out too far.

- The remaining spindle, above the stop of the quick jack nut, must be completely in the vertical.

- Do not force the quick jack nuts up beyond the pinch.

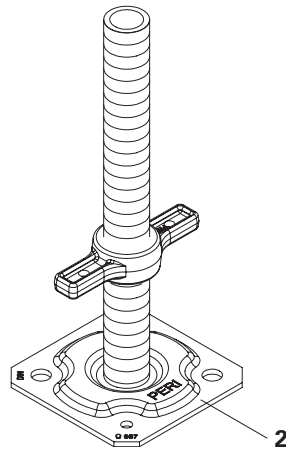

Fig. A1.03

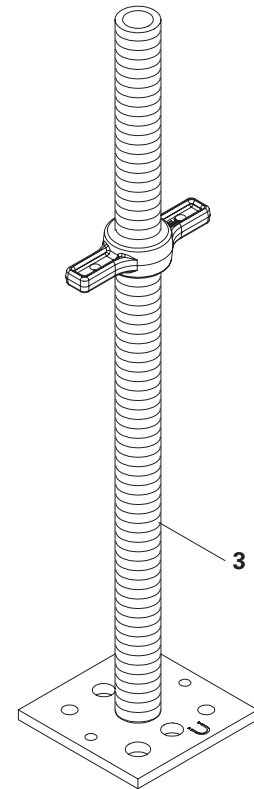

Fig. A1.03a

- Base spindles (**2/3**) do not have a pin hole, to make a connection with the base spindle lock, e.g. for crane repositioning.
- Use base spindles only on a level substrate. Compensate for height differences by turning the quick jack nut.

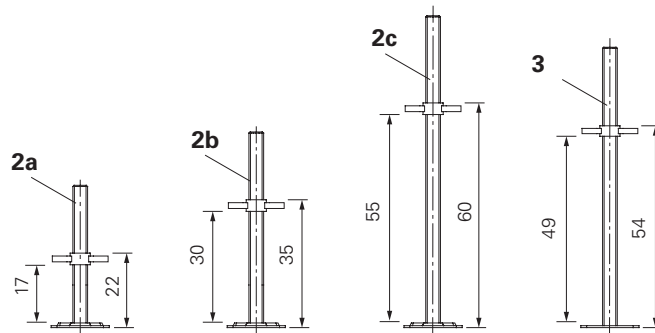

Fig. A1.03b

Technical data				
Base spindle	Spindle length _{min}	Adjustment travel	Spindle length _{max}	Colour of Quick Jack Nut
UJB 38-36/17 (2a)	5 cm	17 cm	22 cm	galvanised
UJB 38-50/30 (2b)	5 cm	30 cm	35 cm	red
UJB 38-80/55 (2c)	5 cm	55 cm	60 cm	yellow
TR 38-70/50 (3)	5 cm	49 cm	54 cm	galvanised

Tab. A1.01

Application examples

Working, protective, industrial and shoring scaffolds.

Pivoting Base Spindle UJS 38-80/50



Note

Observe the maximum spindling length!

- ⇒ Pivoting Base Spindles UJS must be immersed at least 21 cm in the vertical above.
- ⇒ The quick jack nut is secured by a pinch on the threaded rod to prevent it from spinning out too far.
 - The remaining spindle, above the stop of the quick jack nut, must be completely in the vertical.
 - Do not force the quick jack nuts up beyond the pinch.

Pivoting Base Spindles UJS (4) are used when there is no other possibility to align the substrate horizontally.

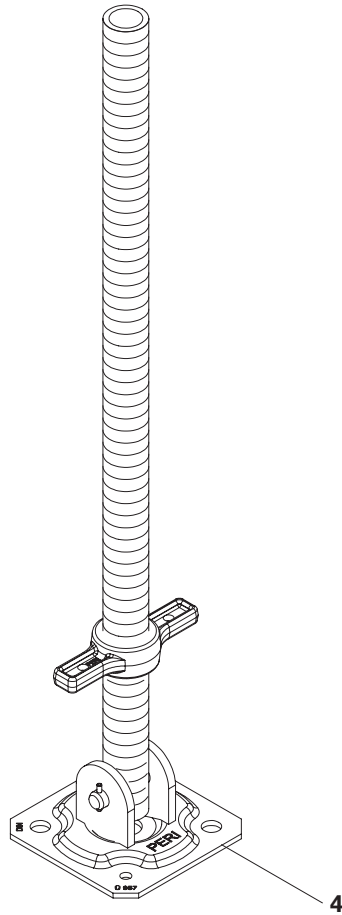
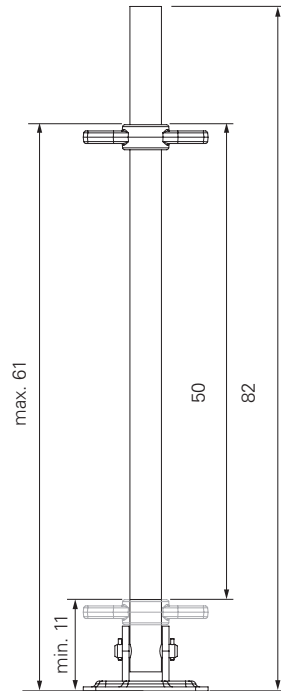

Fig. A1.04



Technical data

- No base restraint can be applied.
- Adjustment travel 50 cm.
- Spindling length min. 11 cm, max. 61 cm.
- For permissible axial force F in the spindle under different inclinations of the base plate see table A1.02
- The permissible values in table A1.02 refer to the base spindle/base plate area. The spindle tube must be verified separately to match the selected spindling length!
- Up to an installation angle of 15° on concrete or wood, no securing with screws is required. For other substrates, it must be verified that horizontal shifting is not possible.
- From an installation angle of 15° , the base plate must be secured with screws at the marked holes ($\varnothing 11$ mm). The screw head must lie flat against the base plate. Pre-tensioning of the screw is not necessary.

The anchoring means is to be determined on site and must have the following rated resistances:

$$F_{tRd} \geq 17.00 \text{ kN limit tensile force,}$$

$$F_{vRd} \geq 21.70 \text{ kN limit shear force.}$$

Application examples

Working, protective, industrial and shoring scaffolds.

Permissible axial force F in the spindle at inclination α	
0 – 15°	30.00 kN
20°	23.00 kN
25°	18.33 kN
30°	15.67 kN
35°	13.33 kN
40°	12.00 kN
45°	11.00 kN
50°	10.00 kN
55°	9.00 kN

Tab. A1.02

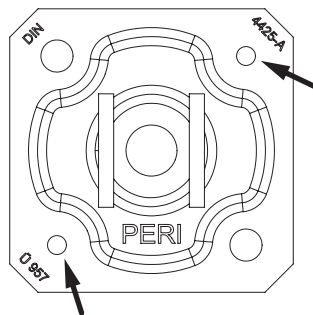

Fig. A1.04a

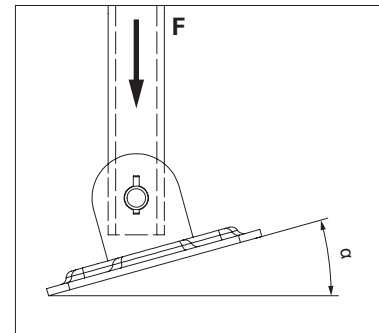

Fig. A1.04b

Swivel castors and castors

Note

- Only move mobile scaffolds without people on them. Attach or remove loose objects.
- Before people climb on or material is put on, check all brakes. Secure castors against rolling away.
 - ⇒ Adjust the spindles of all swivel castors and castors precisely to the substrate after each movement of the scaffold.
 Observe the maximum spindling length!



- For braked castors the static load limit applies, for unbraked castors the dynamic load limit applies. Regardless of whether the scaffold is moved.
- All specified permissible loads only apply when used on a smooth and level substrate, e.g. industrial floor.
- Always verify the load-bearing capacity of mobile scaffold towers on a project-specific basis.
- Attach symmetrically with a load traverse for moving. Do not pull at an angle. Select the attachment point as low as possible.
- Always secure swivel castors and castors against falling out with spindle locking or locking pin.

Components

-
- 5** Castor UEW 30 with spindle
 - 6** Swivel Castor UEW 12 with spindle
 - 7** Swivel Castor UEW 12 with pin
-

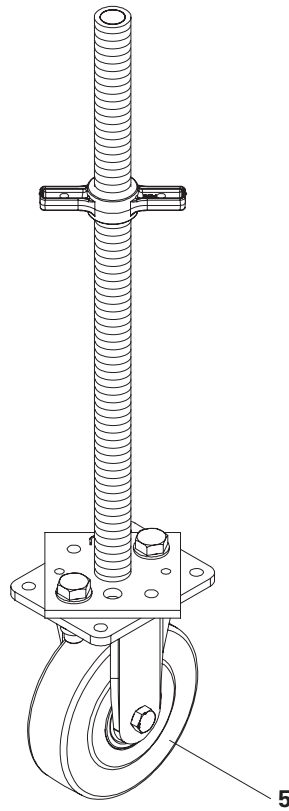

Fig. A1.05

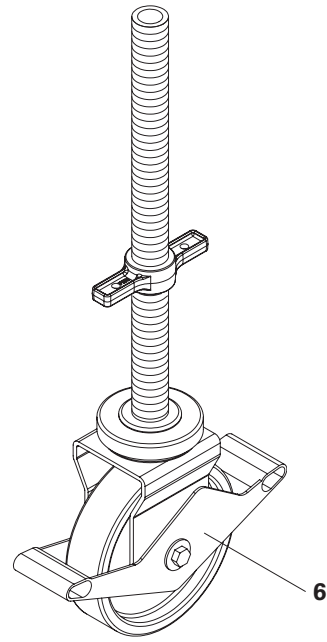

Fig. A1.05a

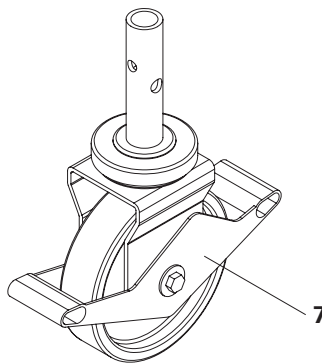

Fig. A1.06

Castor UEW 30

Unbraked, rigid roller with screwed-on base spindle TR 38-70/50.
Castor can rotate by turning the base spindle in the vertical tube.

The castor can be spatially braced with scaffolding tubes and couplings.

- Bracing is possible in a longitudinal and transverse direction as well as diagonally.
- The castor can then no longer be turned.

Assembly

1. Align Castors UEW (5) parallel in the desired direction of travel.
2. Screw the scaffolding tube with Red. Swivel Coupling RS 38/48 (89) directly above the screw-on plate to the base spindle.

Application examples

Working platforms, stripping carts, cornice cap trolleys.

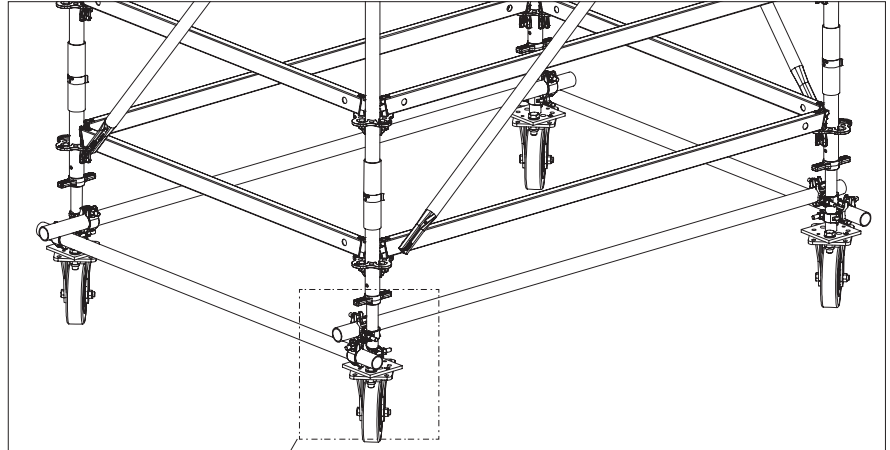

Fig. A1.07

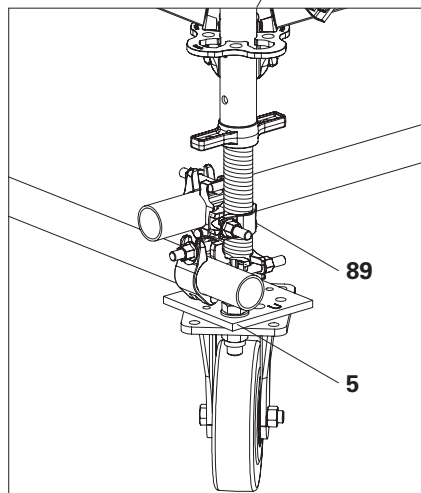

Fig. A1.07a

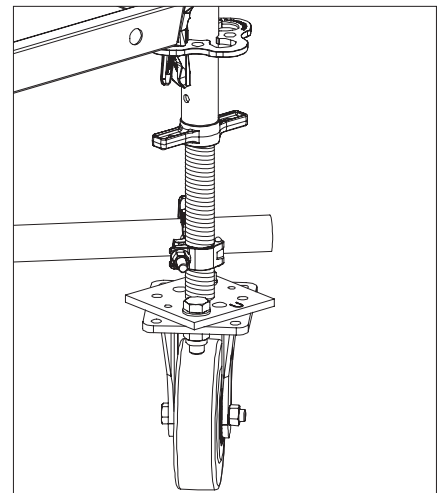

Fig. A1.08a

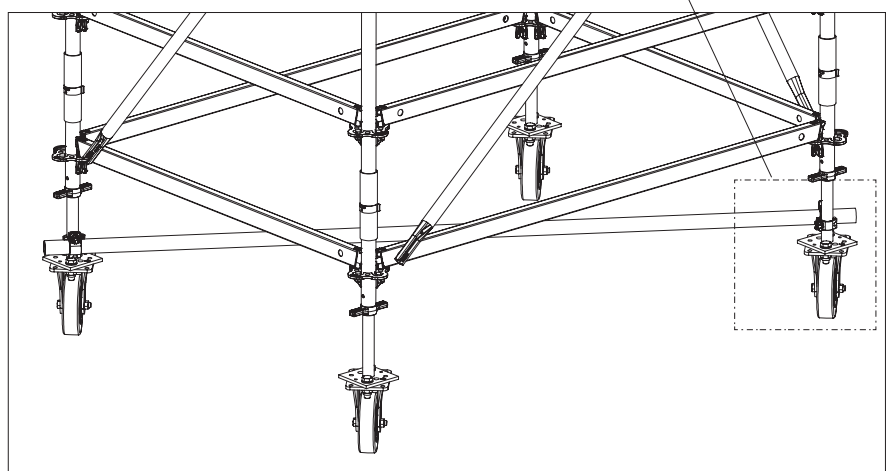

Fig. A1.08

Technical data

See adjacent tables for maximum permissible loads.

The transmittable horizontal force depends on the spindle extension (**x**) and limits the maximum transmittable vertical force.

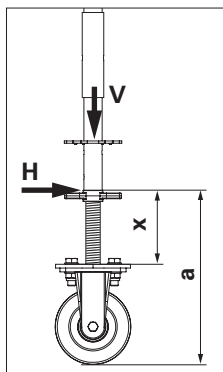

Fig. A1.08b

Permissible load combinations	
Vertical load V [kN]	Horizontal load H [kN]
Spindle extension (x) 35 cm = spindle height (a) 62 cm	
22.50	0.00
15.00	0.65
10.00	1.00
Spindle extension (x) 25 cm = spindle height (a) 52 cm	
27.00	0.00
22.00	0.45
19.00	0.72
16.00	1.00
15.00	1.05
14.00	1.15
13.00	1.25
12.00	1.35
11.00	1.40
10.00	1.50
Spindle extension (x) 20 cm = spindle height (a) 47 cm	
30.00	0.00
27.00	0.35
22.00	0.73
19.00	1.00
18.00	1.10
16.00	1.25
14.00	1.40
12.00	1.55
11.00	1.65
10.00	1.75
Spindle extension (x) 15 cm = spindle height (a) 42 cm	
30.00	0.00
27.00	0.60
25.00	0.82
24.00	1.00
23.00	1.05
21.00	1.15
19.00	1.30
17.00	1.50
15.00	1.60
13.00	1.80
10.00	2.05
Spindle extension (x) 10 cm = spindle height (a) 37 cm	
30.00	0.00
29.00	0.87
28.00	1.00
25.00	1.20
20.00	1.60
15.00	2.00
10.00	2.40

Tab. A1.03

Castor UEW 12 with spindle

Braked, steerable roller with spindle.

- The static permissible load only applies when the brake is fully activated.

Operating the brake

To activate the brake, press the pedal with the red colour marking down up to the stop. (Fig. A1.09a)

To release the brake, press the pedal without the colour marking downwards to the stop. (Fig. A1.09b)

Application examples

Working platforms, reinforcement scaffolds, stripping carts.

Technical data

Maximum permissible load

- dynamic: 6 kN
- static: see Table A1.04

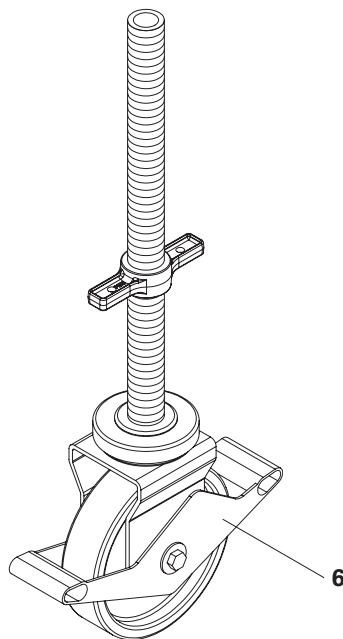

Fig. A1.09

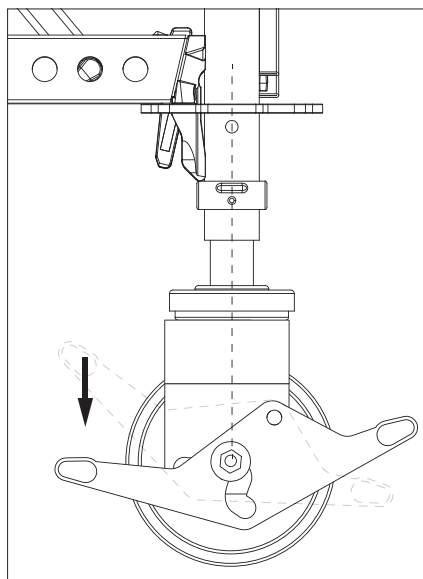

Fig. A1.09a

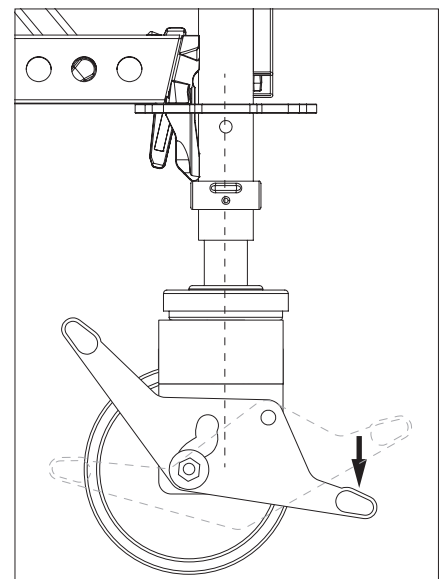
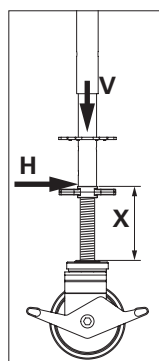

Fig. A1.09b



Permissible load combinations

Vertical load perm. V [kN]	Horizontal load perm. H [kN]
	with spindle extension 17 cm
12.00	2.0
10.00	2.2
8.00	2.4
6.00	2.5
4.00	2.7

Tab. A1.04

Swivel Castor UEW 12 with pin

Braked, steerable castor without height adjustment.

- The static permissible load only applies when the brake is fully activated.

Operating the brake

See Castor UEW 12 with spindle on previous page.

Application examples

Working platforms, reinforcement scaffold, stripping carts.

Technical data

Maximum permissible load	
dynamic	6 kN
static	12 kN

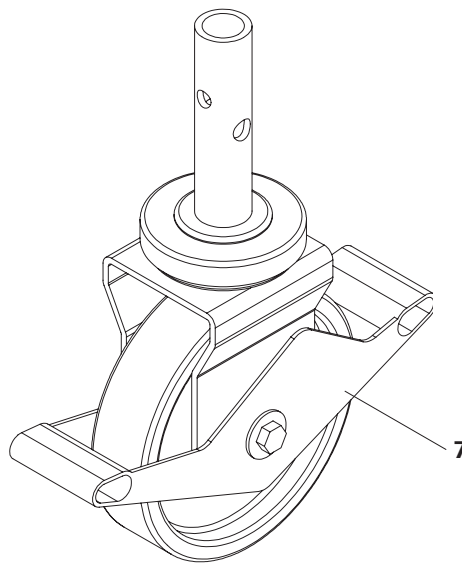
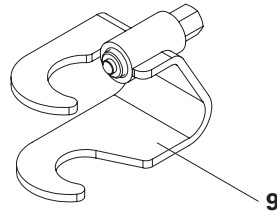

Fig. A1.10

Movement by crane

Spindle locking is required if, for example, the base spindles have to be secured against falling out to enable movement by crane.



Spindle locking is only suitable for enabling movement by crane.
Maximum permissible tensile force
 $Z = 1.5 \text{ kN}$

Components

- 9** Spindle Locking UJS
- 10** Locking Pin D48/D57

Spindle Locking UJS

- A vertical with a stake-out hole, e.g. Base Standard UVB or Standard UVR, UVH, is required for assembly.
- The quick jack nut remains rotatable, the base spindle thus remains adjustable.

Assembly

1. Place the Spindle Locking UJS (**9**) from the side onto the base spindle (**2**) and the base standard. Quick jack nut (**2.1**) must be inside the Spindle Locking UJS. (Fig. A1.11a)
2. Tighten the spindle locking with the screw (**9.1**) in the hole of the vertical (**11**). (Fig. A1.11b)

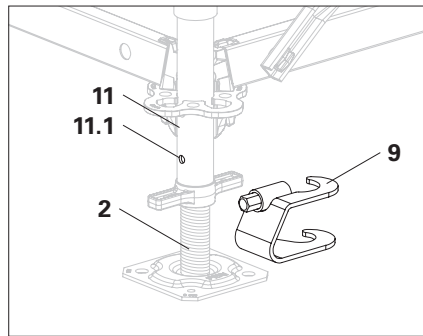

Fig. A1.11a

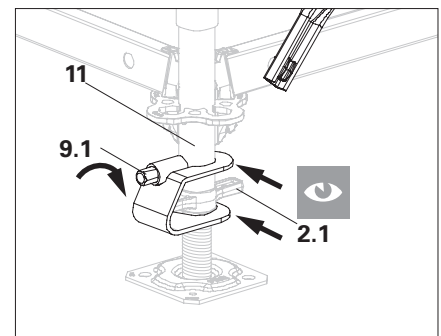

Fig. A1.11b

Locking Pin D48/D57

- For tension- and torsion-proof connection of pin and vertical, e.g. for relocation by crane.

Assembly

1. Align the insert holes with each other.
2. Insert the locking pin \varnothing 48/57 (10) through the holes in both components until the spring clip snaps into place on the tube.

For permissible loads see Section "Tensile couplings" on page 36.

Application examples

Swivel castor with pin, base plate UJP.

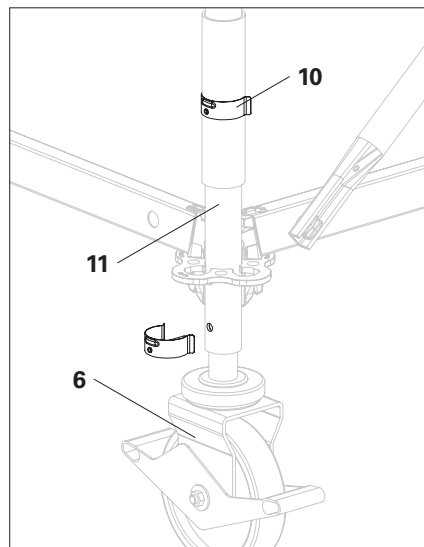
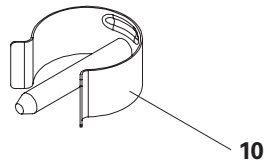

Fig. A1.12

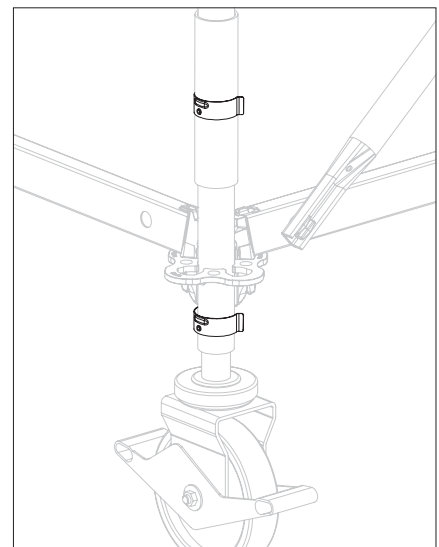

Fig. A1.12a

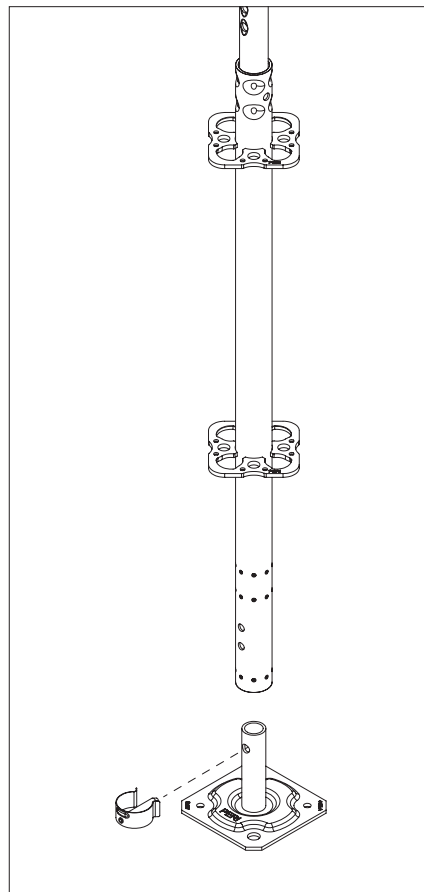

Fig. A1.13

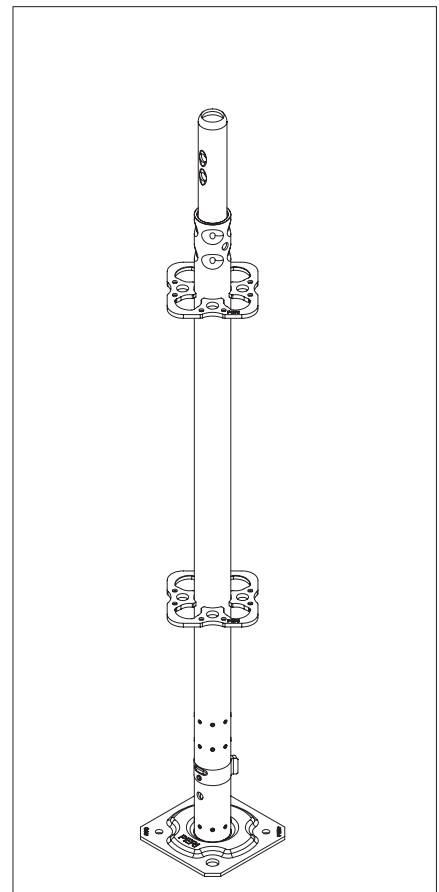

Fig. A1.13a

General

- The load-bearing capacity of standards can only be verified in dependence on the respective system or individual structure. Therefore, no values are given in this section.
- For node load-bearing capacities see the "PERI UP Design Tables"
- Only insert standards vertically. Permissible exceptions are described in the respective Instructions for Assembly and Use.
- The rosettes (**12.1**) of all standards have ledger-to-ledger couplers (**12.2**) and brace adapters (**12.3**).

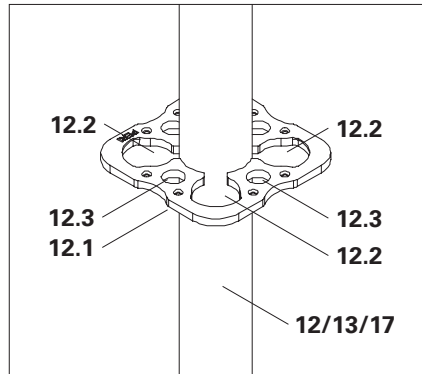

Fig. A2.01

Components

- 2** Base Spindle UJB
- 11** Base Standard UVB
- 12** Standard UVR-2
- 13** Top Standard UVH-2
- 14** Horizontal Ledger UH-2
- 17** Top Standard EVT 96

Base Standard UVB

Base Standards UVB are required when horizontal loads are to be applied close to the point of contact.

Use with

- high loads, e.g. shoring,
- one-man assembly.

Assembly

1. Fit the base standards (**11**) onto the already positioned spindles (**2**).
2. Insert the Horizontal Ledger UH-2 (**14**) into the ledger-to-ledger coupler.
3. Set up another base pair and connect with Horizontal Ledger UH-2.

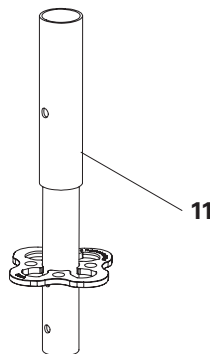

Fig. A2.02a

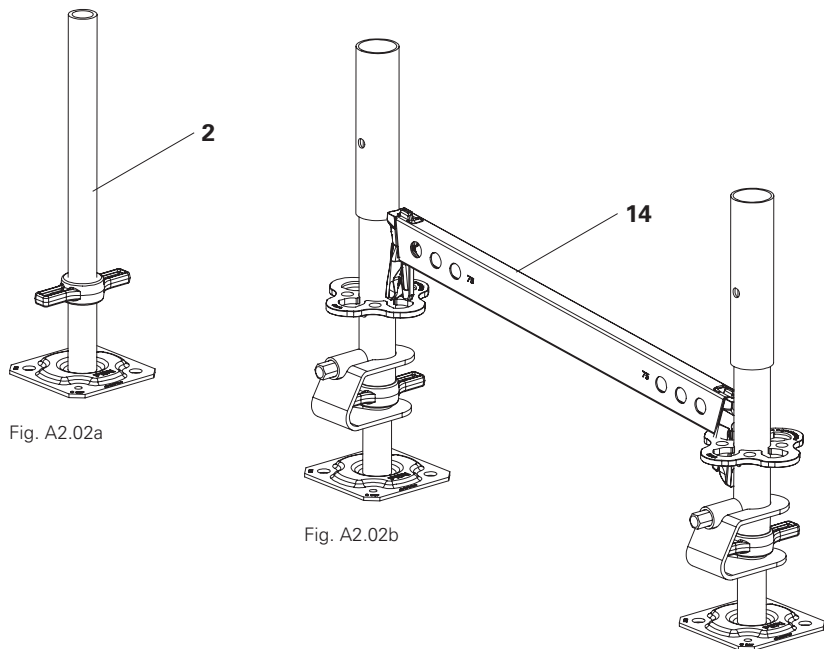

Fig. A2.02b

Standards UVR-2

- Available in lengths of 50, 100, 150, 200 and 300 cm.
- Installation of horizontal ledgers as guardrails possible.
- Can be fitted with guardrails in advance, see Section "Guardrail Post EPG" on page 61.



Start assembly with 4 Standards UVR-2 300 (**12a**) on the base layer. As a result, the end of the vertical is always 1 m above the deck level. Assemble further scaffolding levels with Standards UVR-2 200, e.g. for scaffold exteriors. Instead of the UVR-2 300, a UVR-2 100 (**12c**) can be combined with a UVR-2 200 (**12d**).

Alternatively:

Start assembly with Standards UVR-2 200 (**12b**). As a result, the end of the vertical is at deck level.

It is not possible to use a guardrail in advance, e.g. for the inner side of the scaffold.

Assembly

1. Insert Standard UVR-2 (**12a/12b**) into Base Standard UVB 25 (**11**) or onto Standard UVR-2. (Fig. A2.03a)
2. Align the insert holes with each other. (Fig. A2.03b)

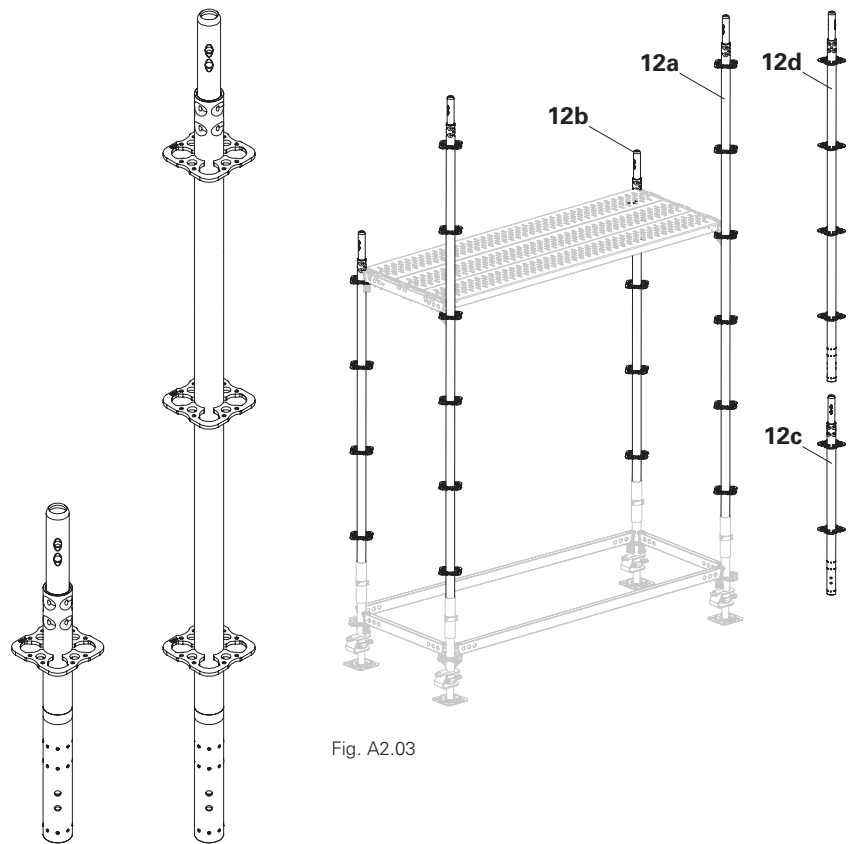

Fig. A2.03

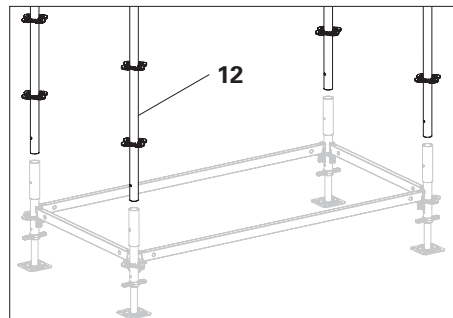

Fig. A2.03a

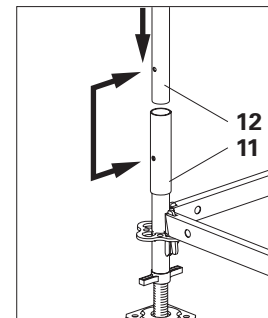

Fig. A2.03b

Top Standard UVH-2 Top Standard EVT 96

Top Standards UVH-2 (**13**) are required, for example, if a spindle is to be inserted into the tube end. On platforms there is a 4 cm projection. (Fig. A2.04a)

A deck surface without protruding tube ends can be produced with the Top Standard EVT 96 (**17**). (Fig. A2.04b)

- The use of the Top Standard UVH-2 50 with head spindle is geometrically only possible to a limited extent. The spindle of the top standard can collide with the pin of the last Standard UVR-2. Then use Top Standard UVH-2 100 and fit a final standard that is 50 cm shorter.
- Above a top standard it is possible to continue building when the Connector ULT 32 is installed. See Section "Connector ULT" on page 131.

Assembly

1. Put the Top Standard UVH-2 (**13**) on the Standard UVR-2 (**12**).
2. Align the insert holes with each other. (Fig. A2.04)

Application examples

Shoring towers, top scaffolding level with roof catch, birdcage scaffolds.

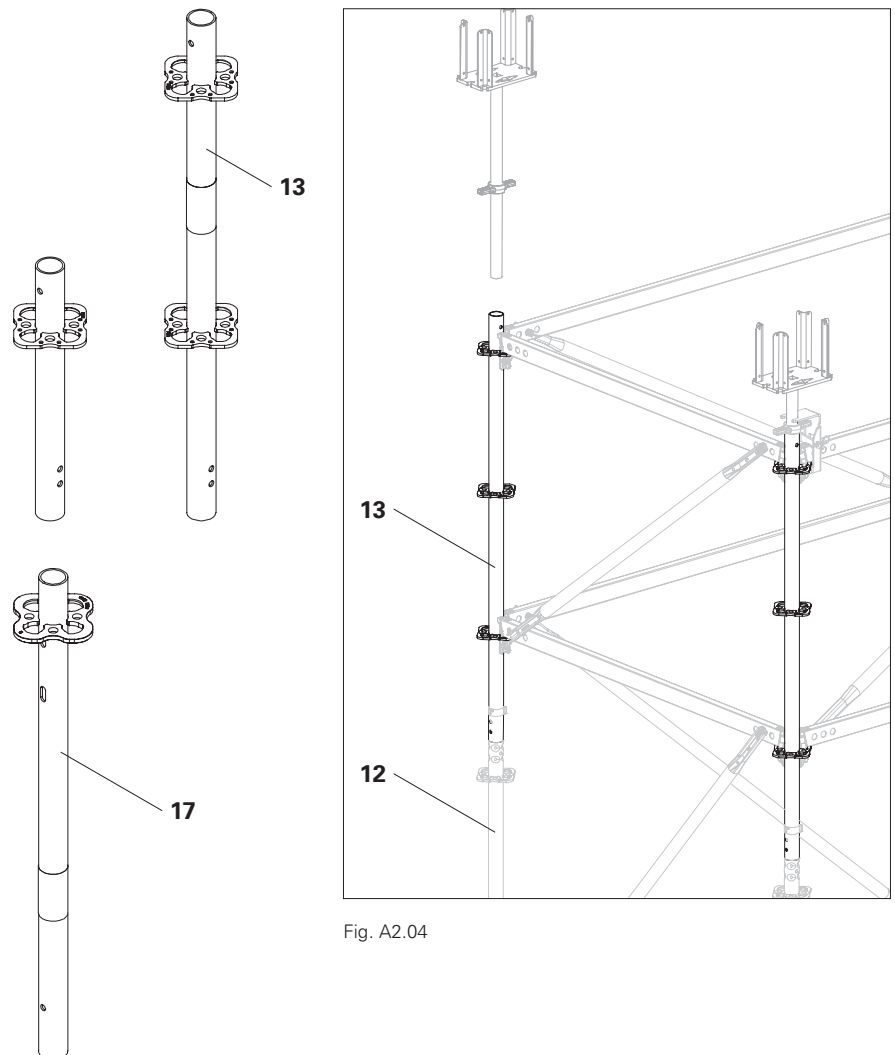

Fig. A2.04

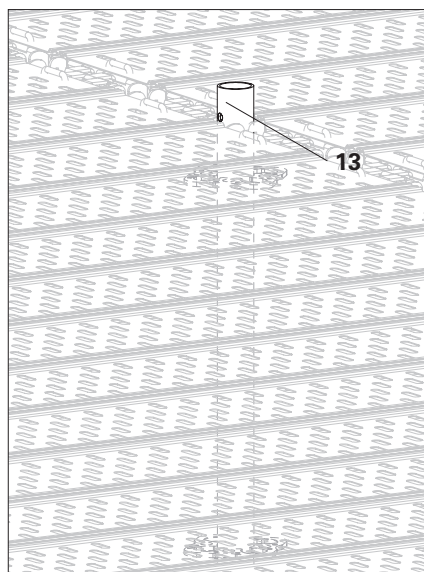

Fig. A2.04a

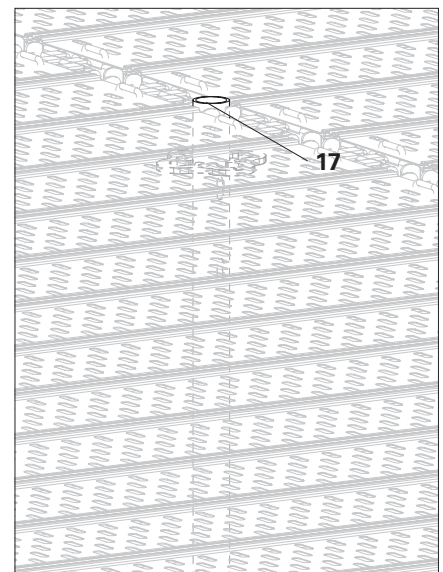

Fig. A2.04b

Hanging verticals used

Rosette on steel waler

To attach a scaffold, Top Standards UVH and UVH-2 (**13**) can be inserted through Steel Walers SRU and placed on the girder with rosettes.

The permissible tension forces of the respective Top Standard UVH or UVH-2 can be fully absorbed.
(See Section "Tensile couplings" on page 36.)

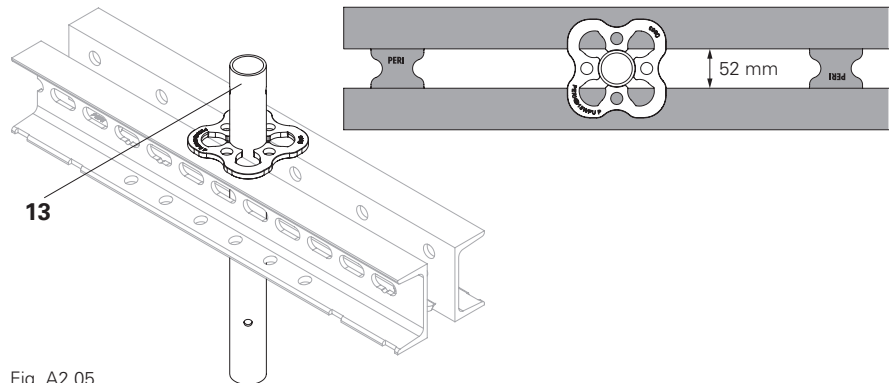

Fig. A2.05



- The alignment of the rosette is freely selectable.
- The max. permissible gap width is 52 mm.
- PERI recommends using a Steel Waler SRU.
- Also possible with Standards UVR/ UVR-2.

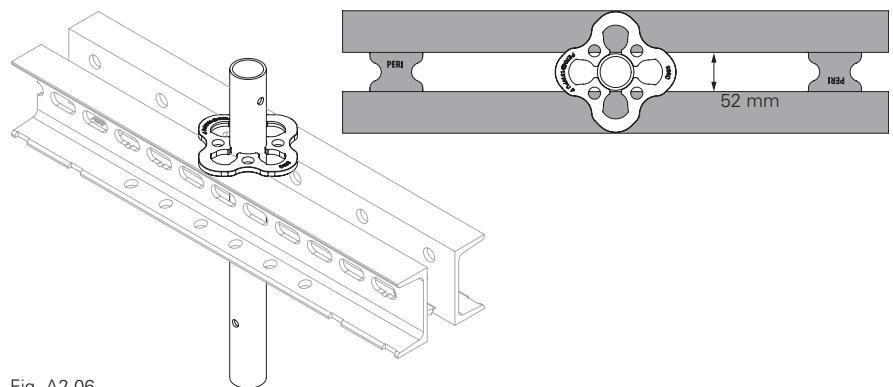
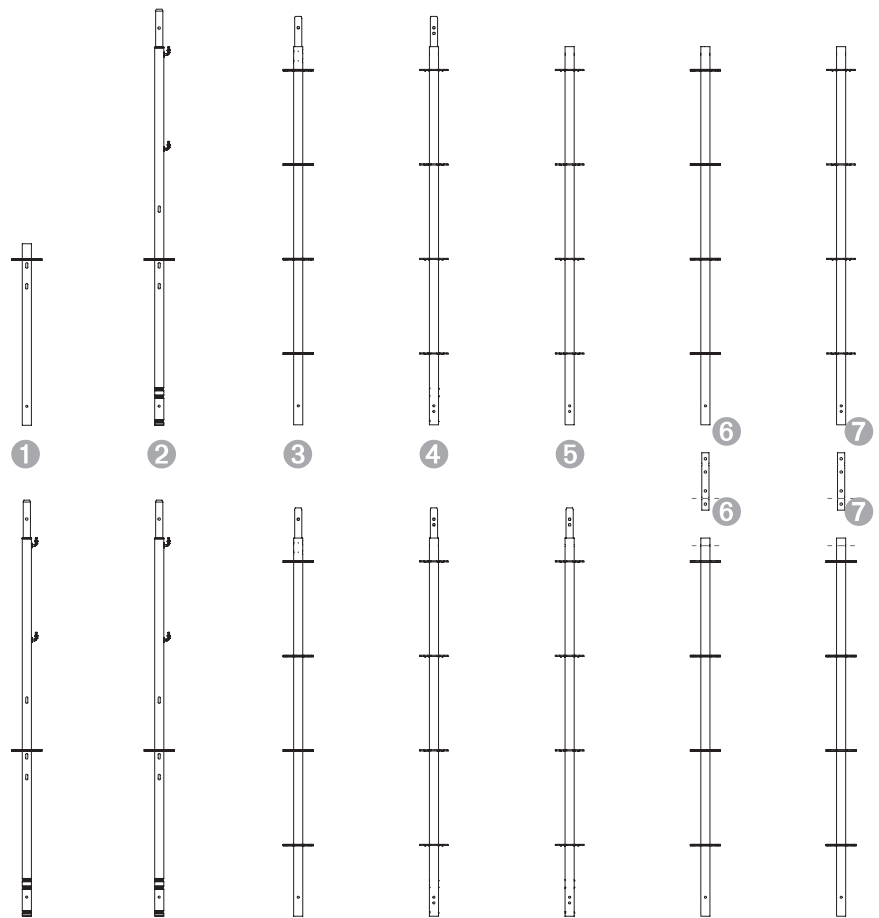

Fig. A2.06

Tensile couplings

Depending on the components used and the fasteners selected, different tensile forces are permissible for suspended constructions.

If only one is used for components with 2 pegging holes, the pegging hole used can be freely selected.



Permissible tension forces [perm.Z] for the fastener*					
Position	Component		Fastener*	Number	perm. Z [kN]
	upper	lower			
1	EVT 96	EVM	a b c	1	13.10
2	EVM	EVM	a b c	1	13.10
3	UVR/UVH	UVR/UVR-2	a b c	1	20.70
4	UVR-2	UVR-2	a	1	12.30
4	UVR-2	UVR-2	b	1	11.90
4	UVR-2	UVR-2	c	1	15.70
4	UVR-2	UVR-2	a	2	24.50
4	UVR-2	UVR-2	b	2	23.90
4	UVR-2	UVR-2	c	2	31.30
5	UVH	UVR-2	a b c	1	20.70
5	UVH-2	UVR-2	a b c	2	31.30
6	UVH/UVR	ULT + UVH	a b c	2 x 1**	20.70
7	UVH-2	ULT + UVH	a b c	2 x 1**	20.70

* a = Locking pin D 48/57

b = Screw M10 – 8.8

c = Screw M10 – 10.9

** see Section "Connector ULT" on page 131

Tab. A2.01

Comparison of components

As part of ongoing product optimisation, the following components have been replaced by 2nd generation components.

The following comparison tables describe the features of the 1st and 2nd generation.



1st and 2nd generation components can be combined.

- The optimised components are available under a new article number.
- There may be a difference between the load-bearing capacity of the individual components in the previous version and the new version.

Standard UVR

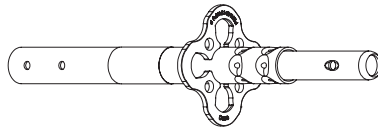

Standard UVR-2

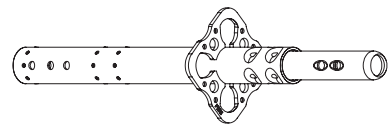

Tube	RO 48.3 mm x 3.2 mm	RO 48.3 mm x 2.7 mm , embossed points on the bottom vertical.
Tube-pin connection	2 rows, with 5 pinch points each	2 rows, with 4 pinch points each
Rosette	160 mm x 130 mm x 8 mm	152 mm x 120 mm x 6 mm
Hole for suspended scaffold	1 hole perm. F up to 20 kN when fixed 1x	2 holes perm. F up to 15 kN when fixed 1x perm. F up to 31 kN when fixed 2x
Marking	none	striped band at the top and bottom
Combinability	Geometrically and statically* combinable in the system. * The standard configurations in the Instructions for Assembly and Use only apply in conjunction with Horizontal Ledgers UH Plus/UH-2 and UHV Plus/UHV-2. * The load tables shown in the Instructions for Assembly and Use for the Heavy-Duty Prop HD and Shoring Tower Plus systems do not apply to use of the Standard UVR-2. Check the statics beforehand!	

Tab. A2.02

Top Standard UVH

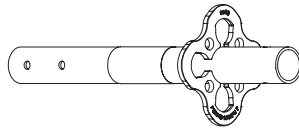

Top Standard UVH-2

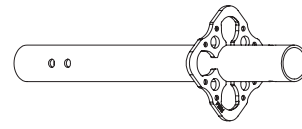

Tube	RO 48.3 mm x 3.2 mm	RO 48.3 mm x 3.2 mm
Rosette	160 mm x 130 mm x 8 mm	152 mm x 120 mm x 6 mm
Hole for suspended scaffold	1 hole perm. F up to 20 kN when fixed 1x	2 holes perm. F up to 15 kN when fixed 1x perm. F up to 31 kN when fixed 2x
Combinability	Geometrically and statically combinable in the system.	

Tab. A2.03

Base Standard UVB 24/49

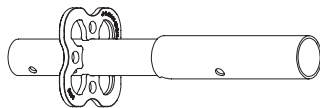

Base Standard UVB 25/50

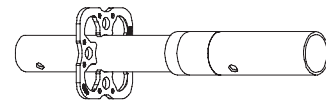

Tube	RO 48.3 mm x 3.6 mm	RO 48.3 mm x 3.6 mm
Rosette	160 mm x 130 mm x 8 mm	152 mm x 120 mm x 6 mm
System height	24/49 cm	25/50 cm
Combinability	Geometrically and statically combinable in the system.	

Tab. A2.04

Horizontal ledger

Horizontal Ledgers UH Plus or UH-2 (**14**) are used as horizontal bracing and as girders.

Horizontal Ledgers UHV or UHV-2 (**15**) are used for high loads, e.g. for material storage or ballasting.

In connection with the UHA-2 Ledger-to-Ledger Coupler, bridging devices can be fitted, see Section "Ledger-to-Ledger Coupler UHA" on page 123 ff.

For permissible linear or concentrated loads, see "PERI UP Design Tables".

Horizontal ledgers can be installed up to 15° out of alignment. The stated load-bearing capacities lose their validity in this case. (Fig. A3.03)

Components

- 14** Horizontal Ledger UH-2
- 15** Horizontal Ledger UHV-2

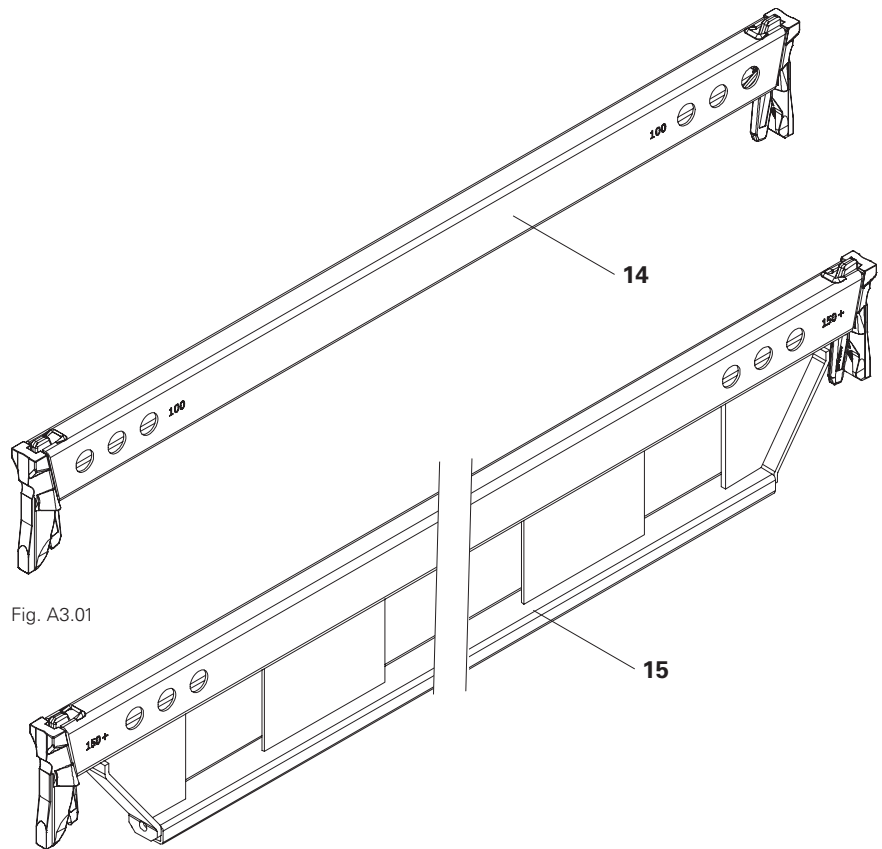

Fig. A3.01

Fig. A3.02

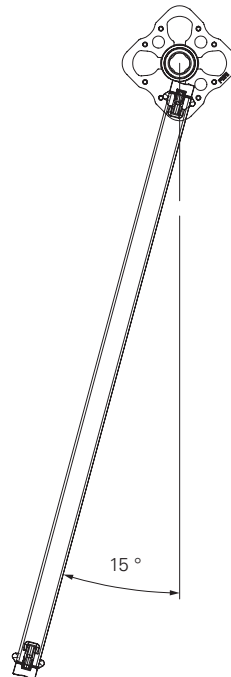

Fig. A3.03

Wedge couplings

Wedges (**14.1**) are used to connect various components, such as horizontal ledgers (**14**), console brackets or connectors. The assembly is always done in the same way.

Assembly

1. Place Horizontal Ledger UH (**14**) or UHV diagonally on both rosettes and set vertically. (Fig. A3.04a)
2. Press the horizontal ledger down onto the rosette up to the stop.
→ Wedges (**14.1**) drop into the rosette and thus already hold the component securely.
If the wedge does not fall, push the wedge nose (**14.2**) down from the horizontal ledger by hand. (Fig. A3.04b + A3.05a)
3. Secure the wedges with a jarring blow using a 500 g hammer. (Fig. A3.04c)
→ Horizontal ledger is installed.

Loosening the wedge connection:

1. Hit the wedge from below with a hammer. (Fig. A3.05)
2. Lift out the wedge and place it on the horizontal ledger with the wedge nose (**14.2**). (Fig. A3.05a)

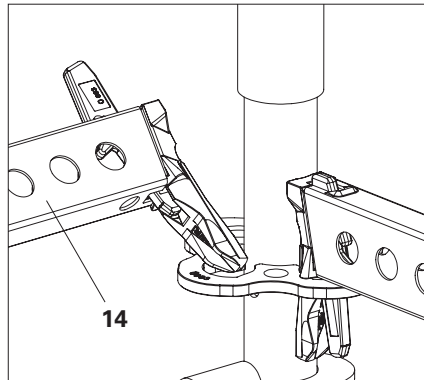

Fig. A3.04a

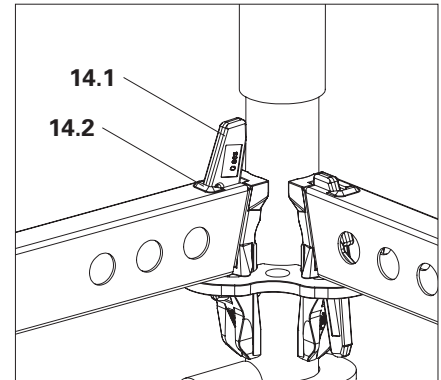

Fig. A3.04b

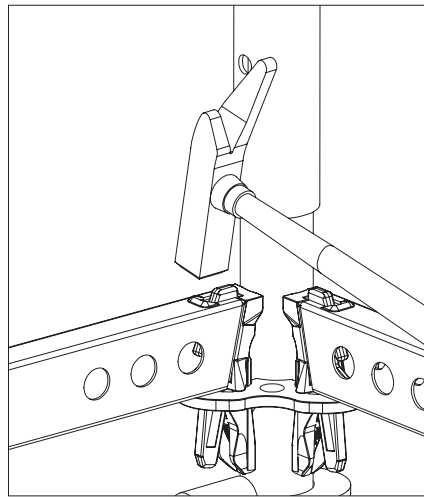

Fig. A3.04c

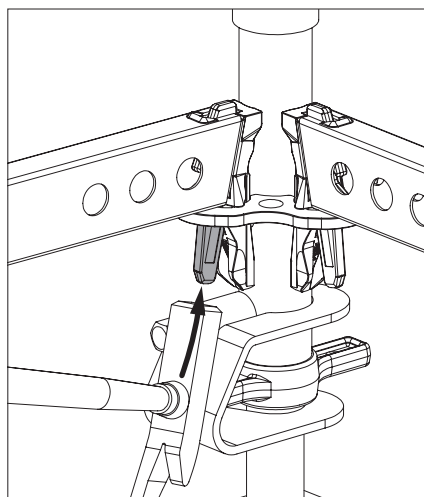

Fig. A3.05

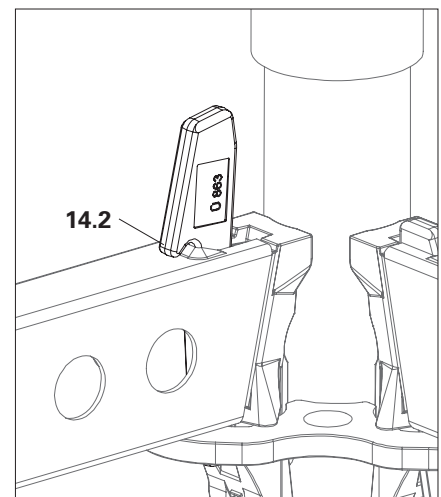

Fig. A3.05a

Comparison of components

As part of ongoing product optimisation, the following components have been replaced by 2nd generation components.

The following comparison tables describe the features of the 1st and 2nd generation.



1st and 2nd generation components can be combined.

- The previous components are no longer available as new components.
- The optimised components are available under a new article number.
- There may be a difference between the load-bearing capacity of the individual components in the previous version and the new version.

Horizontal Ledger UH Plus/UHV Plus

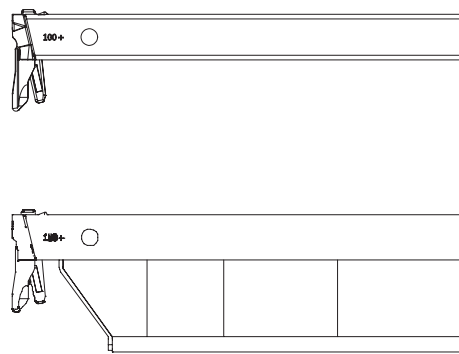

Horizontal Ledger UH-2/UHV-2

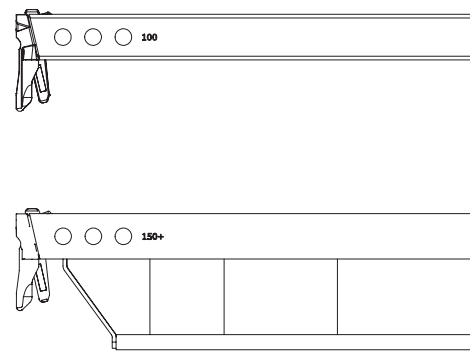

<p>UBL assembly points</p>	<p>2 x 1, for assembly of a Ledger Brace UBL</p>	<p>2 x 3, for assembly of up to three Ledger Braces UBL When installing only one ledger brace preferably use the middle assembly point. Ledger Braces UBL can be mounted at very flat installation angles using the middle assembly point only. Check the geometry beforehand!</p>
<p>Combinability</p>	<p>Geometrically and statically combinable in the system.</p>	

Tab. A3.01

General

Braces are used for bracing scaffolding systems in all axes. Different components are required depending on the intended use.

- For permissible loads, see PERI UP tables.
- The exact position of the braces can be found in the respective System Instructions for Assembly and Use or in the implementation plans.

Components

-
- 20** Horizontal Brace UBH Flex
 - 21** Node Brace UBK-2
 - 22** Coupler Brace UBC-2
 - 23** Ledger Brace UBL-2
 - 24** Shoring Brace UBS
-

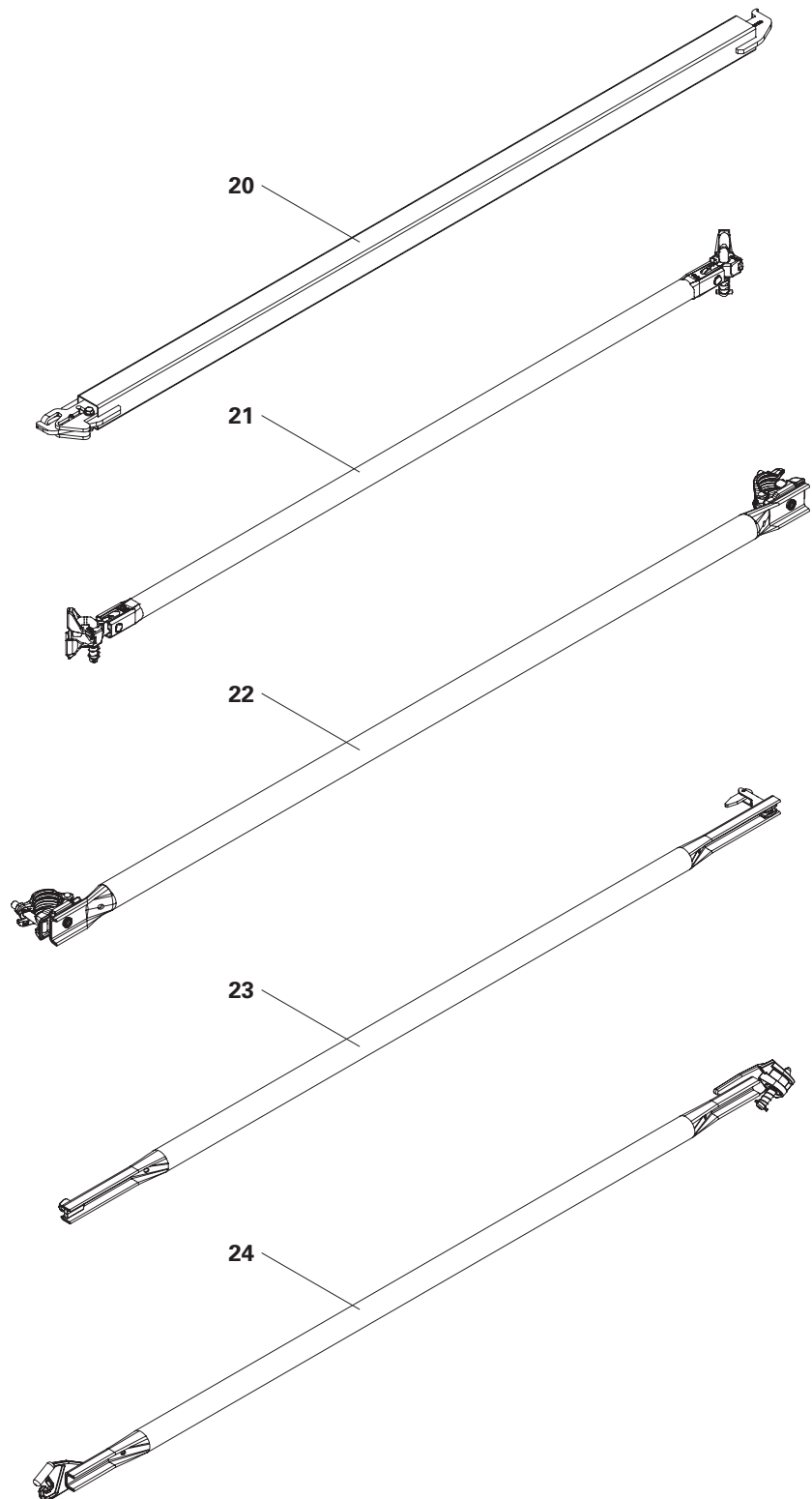

Fig. A4.01

Horizontal Brace UBH Flex

Horizontal Braces UBH Flex (**20**) ensure the exact perpendicularity of a scaffold. They absorb diagonally acting forces, e.g. in case of crane relocation.

- Horizontal braces are mounted on the rosette nodes in the horizontal plane. Peripheral bracing is always required, e.g. with horizontal ledgers.
- Horizontal Braces UBH Flex can be installed from above or below.
- Install horizontal braces from below if deck is installed on the same level.

Assembly

- Install the first side:
 1. Thread the mounting lug (**20.1**) of the horizontal brace (**20**) from below into the brace adapter receptacle of the first rosette and secure it by swivelling the brace upwards. (Fig. A4.02a + A4.02b)

Install first side

(Shown without horizontal ledger.)

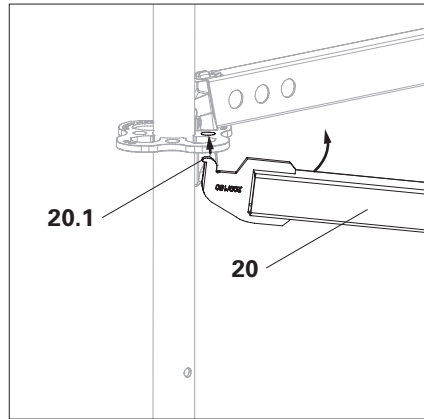

Fig. A4.02a

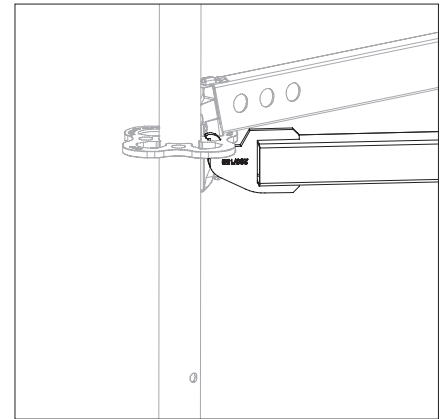

Fig. A4.02b

- Install the second side:
- 2. Push back slider **(20.2)** and insert horizontal brace with hook into the brace adapter of the diagonally opposite rosette from below. (Fig. A4.02c)
- 3. Push the slider in the direction of the rosette until the locking pin **(20.3)** falls into the longitudinal groove. (Fig. A4.02d – A4.02f)
 - Slider is secured.
 - Horizontal brace is installed. (Fig. A4.02)



Is the locking pin **(20.3)** in the longitudinal groove and does it secure the slider?

Application examples

Birdcage scaffolds, shoring towers.

Install second side

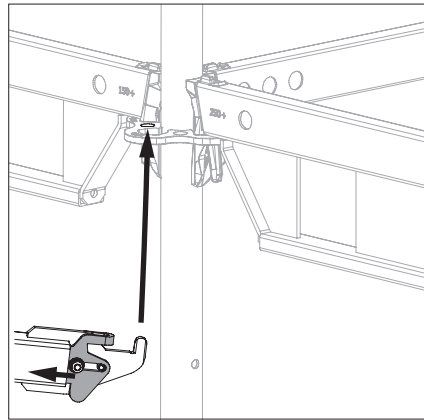

Fig. A4.02c

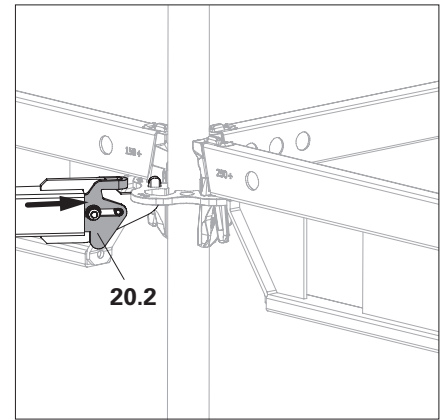

Fig. A4.02d

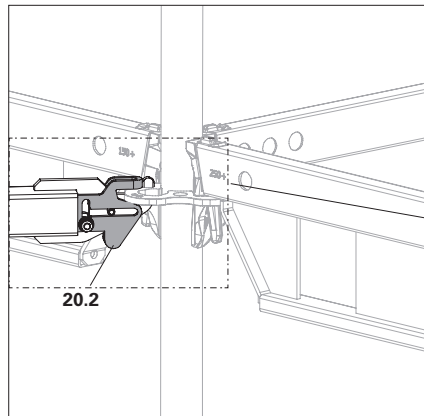

Fig. A4.02e

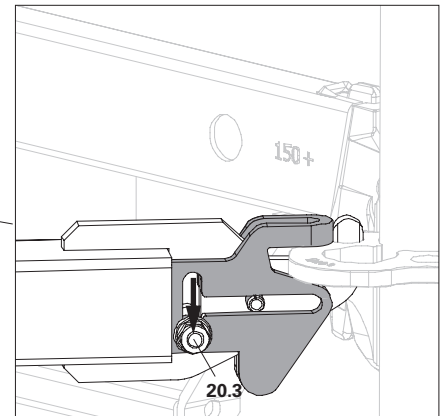

Fig. A4.02f

Node Braces UBK/UBK-2



Caution

Node Brace UBK (21) can tilt forward during installation!

People can be hit and injured.

⇒ Install the Node Brace UBK at the top first!

- Node braces are installed directly on the rosette node.

Assembly

1. Push the brace head (21.1) with raised bolt (21.3) onto the upper rosette (12.1). (Fig. A4.03a)
2. Engage bolt (21.3) completely in the brace adapter (12.3).
→ Node brace is positioned at the top. (Fig. A4.03b)
3. Push the brace head (21.2) with raised bolt (21.4) onto the lower rosette. (Fig. A4.03c)
4. Engage the bolt completely in the brace adapter (12.3) of the lower rosette.
→ Node Brace UBK is installed. (Fig. A4.03d)

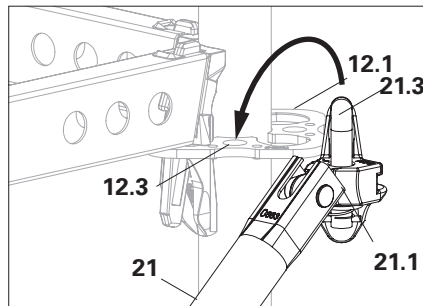

Fig. A4.03a

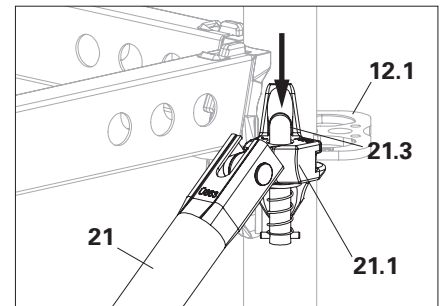

Fig. A4.03b

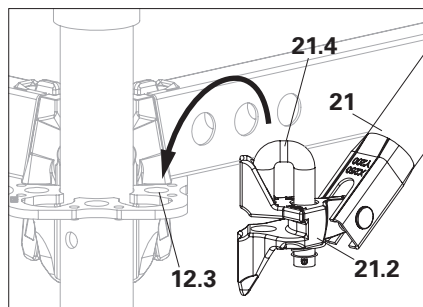

Fig. A4.03c

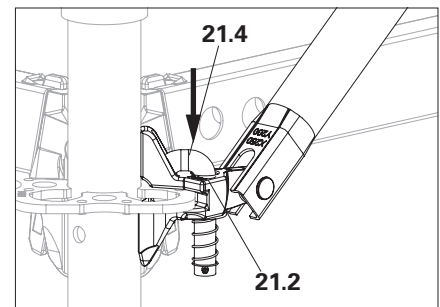

Fig. A4.03d



All bolts (21.3/21.4) must be engaged and rest on the BRACE head (21.1/21.2) after the installation of the Node Brace UBK. (Fig. A4.03b/A4.03d)

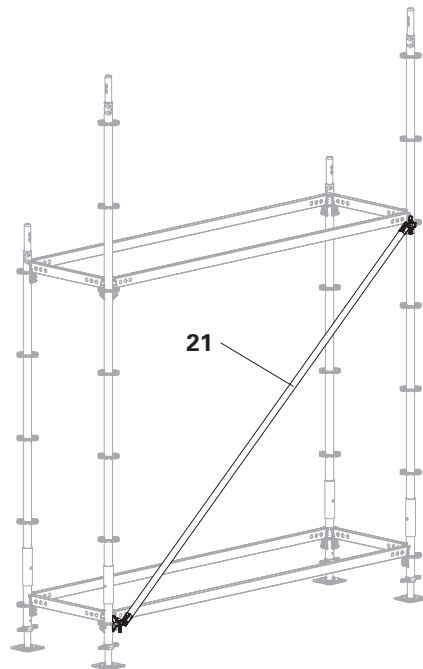

Fig. A4.03

Application example Suspended platforms



- Suspended platforms require individual planning with static proof of load-bearing capacity.
- The safety measures for construction and operation must be determined on a project-specific basis.

Preparation

Insert the horizontal ledger into the ledger-to-ledger coupler of the base standard and hammer it down. On the side that will later be on the outside, fit a Node Brace UBK in the brace adapter of the base standard. For the other side of the platform, carry out the assembly inversely.

Assembly

- From existing base scaffold with lateral protection:
 1. Bring the prepared assembly in front of the base scaffold. (Fig. A4.04a)
 2. Install the node brace on the fixed rosette of the standard, making sure that the bolt is locked in place. (Fig. A4.04b)
 3. Hold the horizontal ledger at the free end and swing the other side outwards with the base standard. (Fig. A4.04c)
 4. Insert the horizontal ledger in the rosette provided on the base scaffold and knock it firmly into place. (Fig. A4.04d)
 5. Install the second platform kicker brace in the same way.
 6. Place the decks on the horizontal ledgers and push them outwards.



Further assembly is carried out according to project-specific planning and risk analysis.

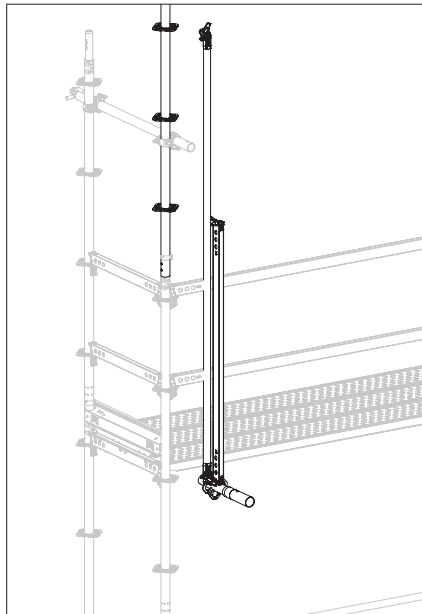

Fig. A4.04a

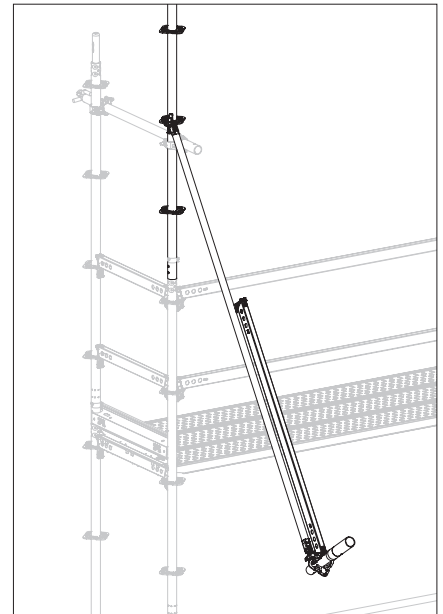

Fig. A4.04b

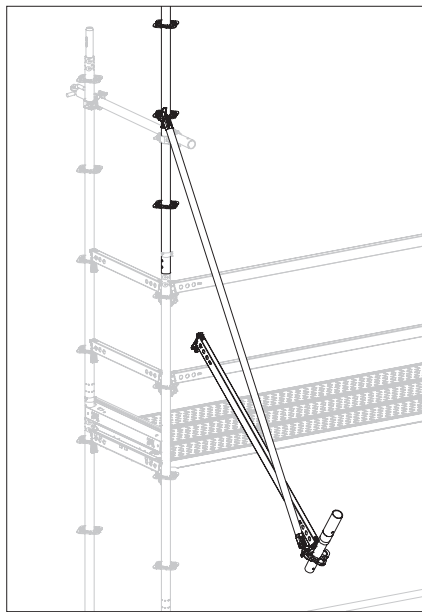

Fig. A4.04c

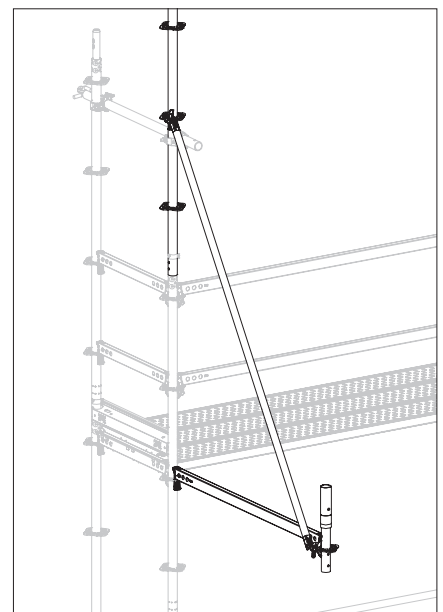

Fig. A4.04d

Comparison of components

As part of ongoing product optimisation, the following components have been replaced by 2nd generation components.

The following comparison tables describe the features of the 1st and 2nd generation.



1st and 2nd generation components can be combined.

- The optimised components are available under a new article number.
- There may be a difference between the load-bearing capacity of the individual components in the previous version and the new version.

Node Brace UBK

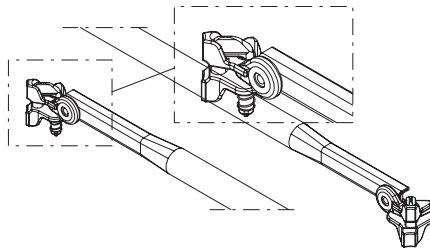

Node Brace UBK-2

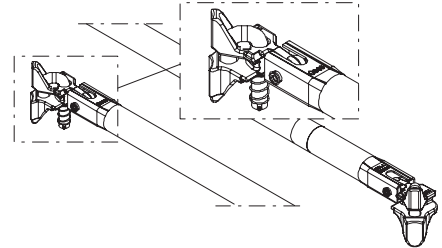

Head piece connected to the diagonal tube	Riveted to crimped tube	Bolted to cast shaped component
Combinability	Geometrically and statically combinable in the system.	
Marking	None	Band at the top and bottom
Features	Galvanised heads	Yellow-coated heads

Tab. A4.01

Coupler Brace UBC-2

Coupler braces (**22**) are required if bracing outside system dimensions must be carried out.

- Tighten the couplings with 50 Nm.
- Couplings and pipes must be clean and free of grease.
- Coupler braces require a pipe diameter of 48 mm.

Assembly

1. Open the couplings (**22.1**).
 2. Place the couplings around the scaffolding tubes and tighten with 50 Nm.
- Coupler brace is installed.



Application examples

Bracing of shoring towers to each other.

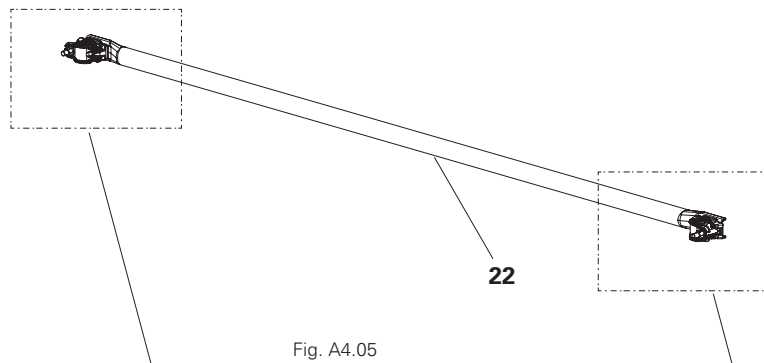

Fig. A4.05

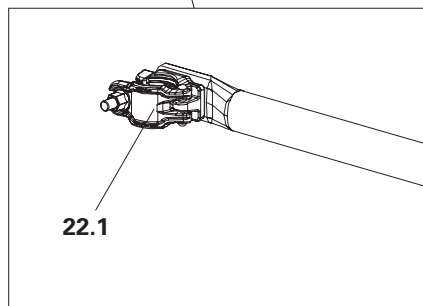

Fig. A4.05a

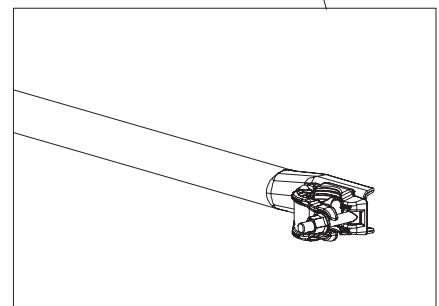

Fig. A4.05b

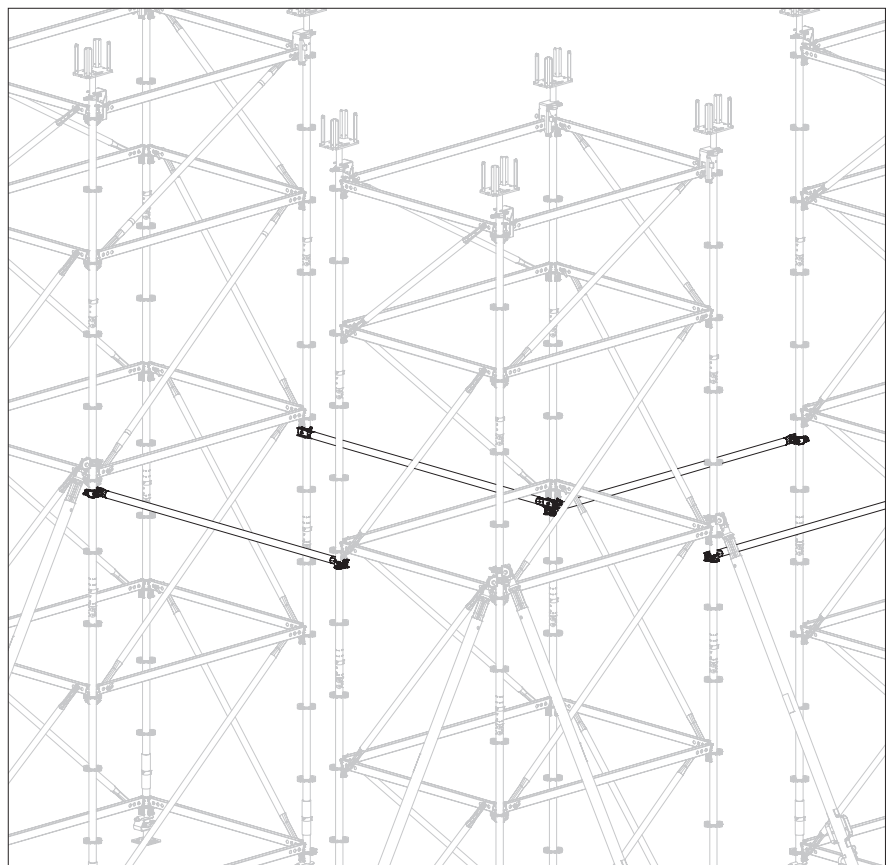

Fig. A4.06

Ledger Brace UBL/UBL-2

→ Check load-bearing capacity!
Before installing the Ledger Braces UBL-2, check the load-bearing capacity for the intended use defined in the proof of use.

The Ledger Brace UBL-2 (**23**) is the most frequently used diagonal in the PERI UP Flex system.

Components

- 14a** Horizontal Ledger UH-2 (bottom)
- 14b** Horizontal Ledger UH-2 (top)
- 23** Ledger Brace UBL-2

Assembly of UBL-2

1. Bring the Ledger Brace UBL-2 (**23**) parallel to the basic scaffold and turn it so that the mounting finger (**23.1**) points upwards. (Fig. A4.07a)
2. Screw the mounting finger into the hole of the lower horizontal ledger (**14a**). (Fig. A4.07b)
3. Straighten the tilt finger (**23.2**). (Fig. A4.07c)
4. Insert the tilt finger into the hole of the upper horizontal ledger (**14b**). (Fig. A4.07d)
5. Set the tilt finger crosswise.
→ Ledger Brace UBL-2 is mounted. (Fig. A4.07e)



All tilt fingers (**23.2**) of the superstructure must be transverse after installation of the Ledger Braces UBL and rest on both sides of the hole (Fig. A4.07e)

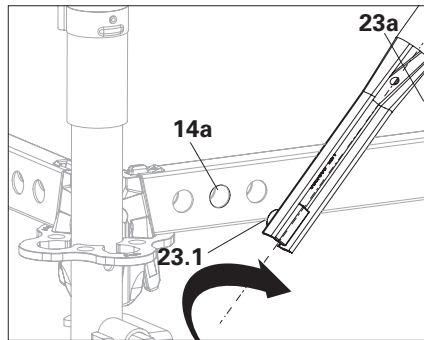

Fig. A4.07a

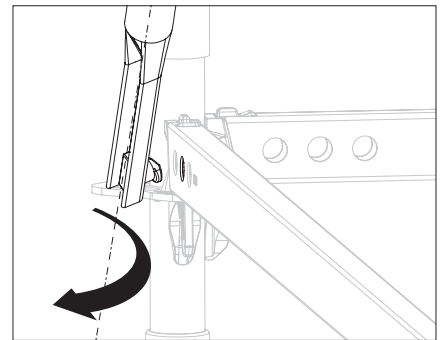

Fig. A4.07b

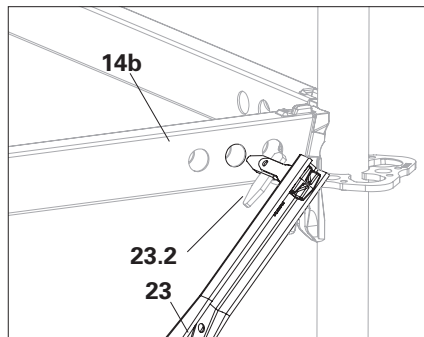

Fig. A4.07c

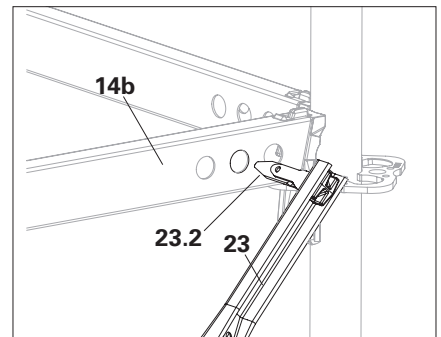

Fig. A4.07d

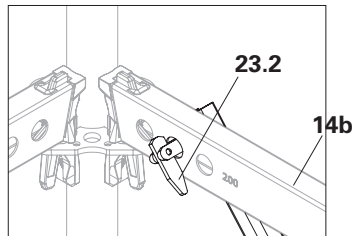

Fig. A4.07e

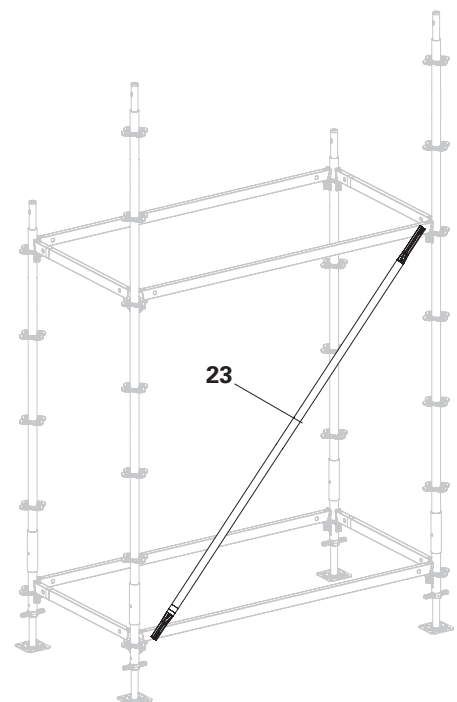

Fig. A4.07

Assembly of UBL

1. Bring the ledger diagonal up to the horizontal ledger at an angle of approx. 45°. (Fig. A4.08a)
2. Insert the mounting finger (**23.1**) of the Ledger Brace UBL (**23a**) diagonally into the hole of the lower Horizontal Ledger UH Plus (**14a**) and swing the ledger diagonal towards the base scaffold. (Fig. A4.08b)
3. Straighten the tilt finger (**23.2**). (Fig. A4.08c)
4. Insert the tilt finger into the hole of the upper horizontal ledger (**14b**). (Fig. A4.08d)
5. Set the tilt finger crosswise. → Ledger Brace UBL is installed. (Fig. A4.08e)



All tilt fingers (**23.2**) of the assembly must be transverse after installation of the Ledger Braces UBL and rest on both sides of the hole. (Fig. A4.08e)

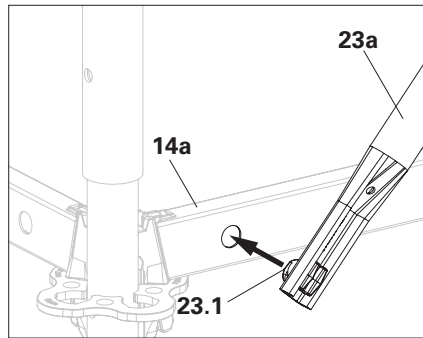

Fig. A4.08a

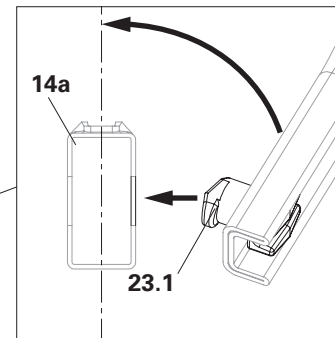

Fig. A4.08b

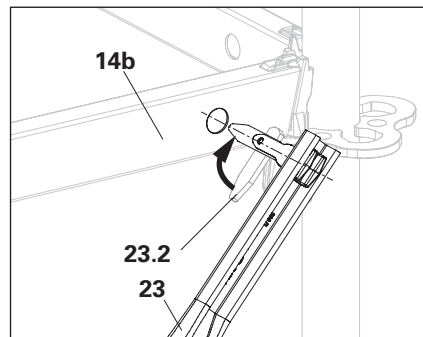

Fig. A4.08c

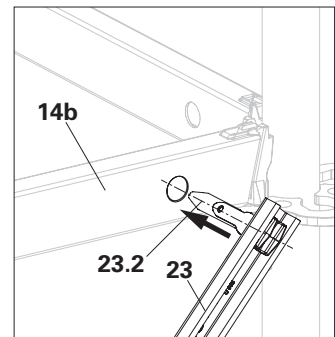

Fig. A4.08d

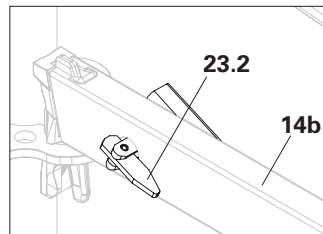

Fig. A4.08e

Ledger Brace UBL/UBL-2 on Horizontal Ledger UH-2

The assembly position of the Ledger Brace UBL-2 (**23**) can be freely selected at three assembly points (**14.1/14.2/14.3**) on the Horizontal Ledger UH-2.

Always select the same installation position on the upper and lower horizontal ledgers. (14.1/14.1, 14.2/14.2, 14.3/14.3)

Up to three ledger braces can be assembled at the same time. The structural stability must be considered separately.

- When mounting a brace, preferably use installation point 14.2.
- When installing 2 ledger braces, use installation points 14.1 and 14.3.
- When installing 3 ledger braces install the third ledger brace on the inside at assembly point 14.2 in order to save space.



- For subsequent braces, the double installation cannot be done in parallel for space reasons:
 - UBL 150/50
 - UBL 200/50
 - UBL 250/50
 - UBL 300/50
 - UBL 200/100
 - UBL 250/100
 - UBL 300/100
 - UBL 300/150
- Only 2 braces are possible per bay.
- If necessary, install the corresponding braces on the inside of the ledgers.
- If the brace is installed on the inside, it may collide with any decks that may be required.

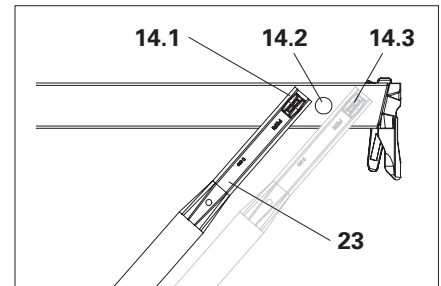

Fig. A4.09a

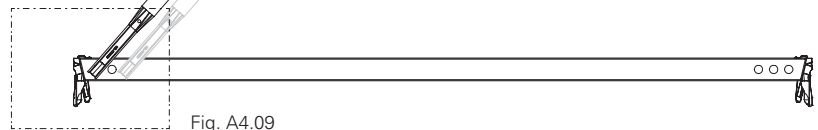
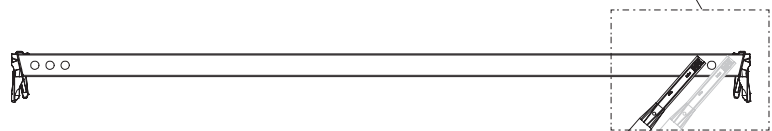

Fig. A4.09

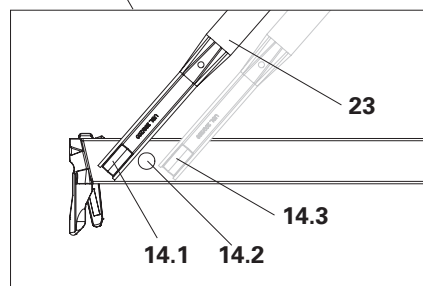

Fig. A4.09b

Comparison of components

As part of ongoing product optimisation, the following components have been replaced by 2nd generation components.

The following comparison tables describe the features of the 1st and 2nd generation.



1st and 2nd generation components can be combined.

- The optimised components are available under a new article number.
- There may be a difference between the load-bearing capacity of the individual components in the previous version and the new version.

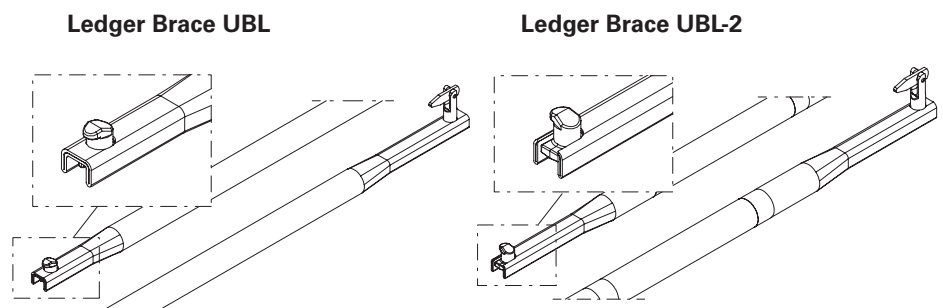

UBL Mounting Lug	Points in the longitudinal direction	Points in the transverse direction
Combinability	Geometrically and statically combinable in the system.	
Marking	None	Band at the top and bottom
Handling	Swivel in to install.	Screw in to install (less lateral space required for installation).

Tab. A4.02

Shoring Brace UBS

Shoring Braces UBS (**24**) engage directly in rosettes like node braces. Compared to node braces, shoring braces have rigid connection heads and are therefore stiffer.

- Always mount the shoring braces from bottom left to top right. Fit opposite braces on the inner side.

Assembly

- Fit the shoring brace at an angle of approx. 45° with the lower diagonal head (**24.1**) onto the lower rosette. (Fig. A4.11a + A4.11c)
 - Insert dowel pin (**24.3**) into the brace adapter (**12.3**). (Fig. A4.11b)
 - Swivel brace to the base scaffold. (Fig. A4.11)
 - Push the upper brace head (**24.2**) with raised bolt (**24.4**) onto the upper rosette. (Fig. A4.11d)
 - Engage bolt (**24.4**) completely in the brace adapter (**12.3**). (Fig. A4.11e)
- Shoring Brace UBS is installed.



Are all dowel pins and spring bolts properly engaged? (Fig. A4.11b, A4.11e)

Application examples

Free-standing scaffolding constructions, for transferring larger horizontal forces.

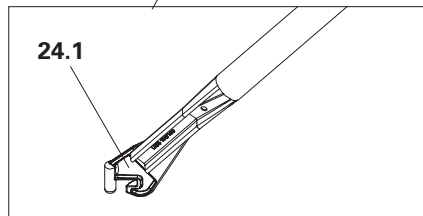
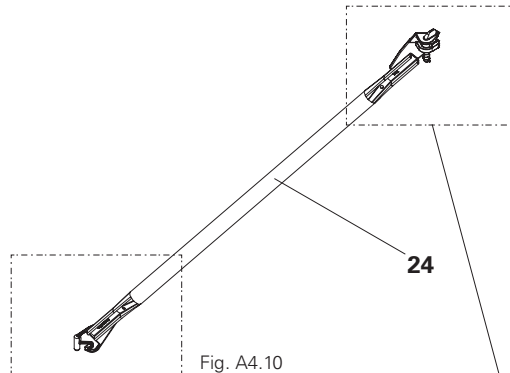

Fig. A4.10a

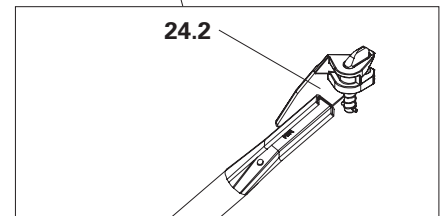

Fig. A4.10b

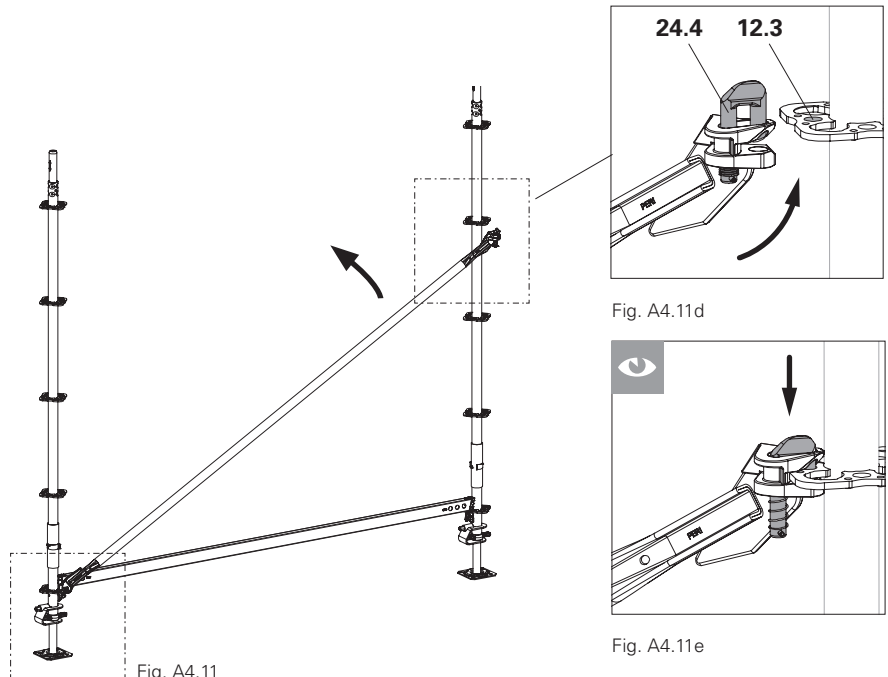

Fig. A4.11

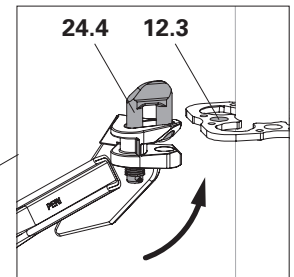

Fig. A4.11d

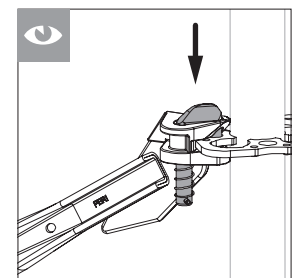

Fig. A4.11e

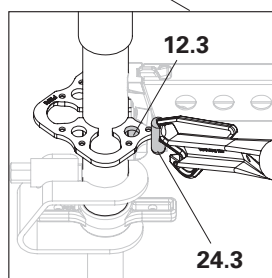

Fig. A4.11a

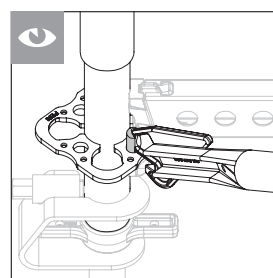

Fig. A4.11b

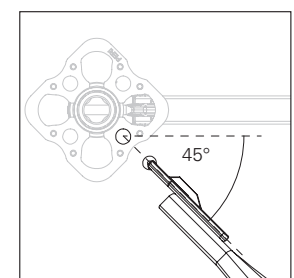

Fig. A4.11c

General



- The components to be used and the assembly sequence are regulated in the respective system-specific Instructions for Assembly and Use.
- In the case of individual superstructures, a safety assessment must be carried out in which suitable safety measures must be prescribed.

Components

- 30** Toe Board UPY
- 31** Toe Board Compensation UPY-L
- 32** Toe Board UPF
- 33** Guardrail Post EPG
- 34** Swing Ledger UPK
- 35** Safety Entry Gate UPS
- 36** End Guardrail in Advance UPA-2

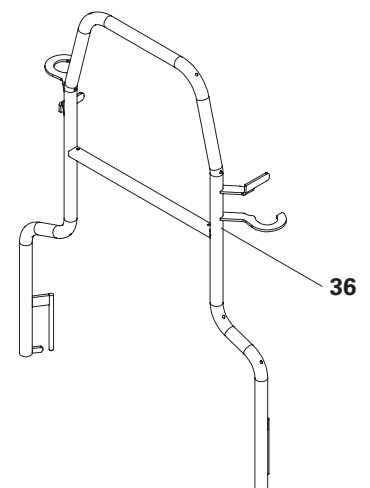
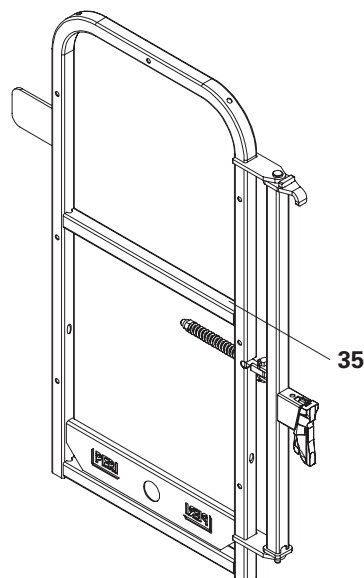
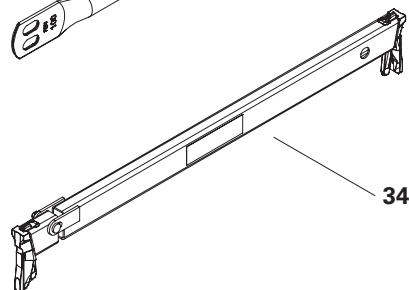
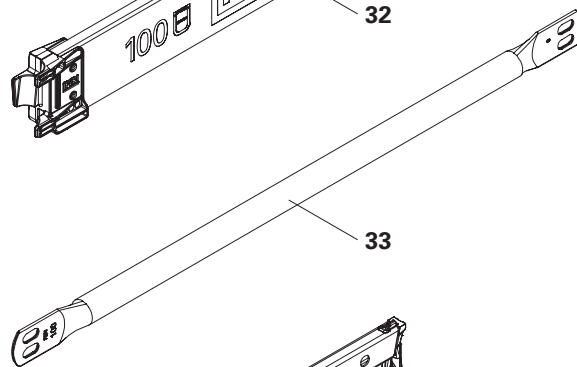
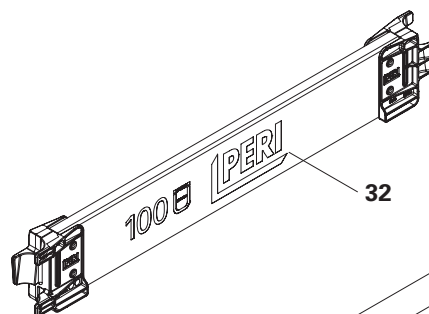
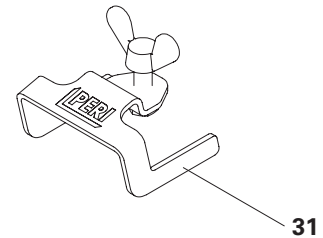
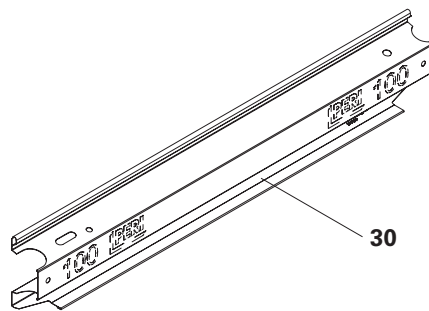

Toe Board UPY



- Toe Boards UPY are correctly installed when each PERI logo is legible.
- Observe the different ends of the Toe Boards UPY:
 - Side with large tube cut-out (30.1) and slot (30.2).
 - Side with semi-circle (30.3) and drilled hole (30.4). (Fig. A5.01a)
- The assembly of the Toe Board UPY-C follows the same procedure.
- In strong winds, additionally secure the Toe Boards UPY using suitable means.

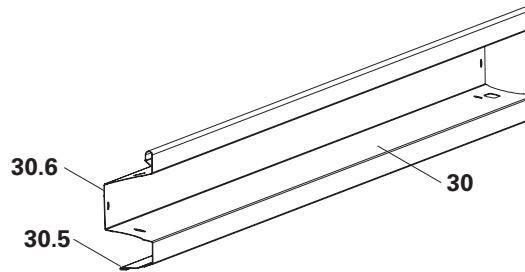

Fig. A5.01

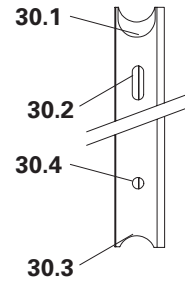

Fig. A5.01a

Assembly in the bay

1. Turn the support bracket (30.5) downwards.
 2. Turn the trapezoid box (30.6) **outwards**.
 - The larger tube section (30.1) is on the right. (Fig. A5.02a)
 3. From the inner side of the scaffold, insert Toe Board UPY (30) at the right-hand tube (12a) first.
 4. Raise the toe board on the left-hand side until it rests on the tube (12b).
 5. Lower the toe board onto the deck. (Fig. A5.02b)
- The toe board is installed.

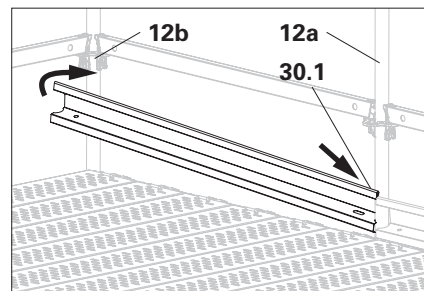

Fig. A5.02a

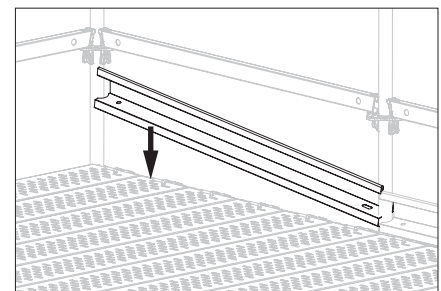

Fig. A5.02b



- When installing and dismantling both Toe Boards UPY over corners, ensure that no unsecured components can fall to the ground.

Assembly around a corner:

- Turn the support bracket (30.5) downwards.
- Turn the trapezoid box (30.6) inwards.
→ The larger tube cut-out (30.1) is on the left.

- On a right-hand corner:

- Insert Toe Board UPY (30) from the outside-left first of all using the large tube cut-out (30.1). (Fig. A5.04a)
- Raise the Toe Board UPY on the right-hand side and position it on the second tube.
- Lower the toe board onto the deck.
→ The toe board is installed.

- On a left-hand corner:

- Insert Toe Board UPY (30) from the outside-left first of all using the large tube cut-out (30.1).
- Raise the Toe Board UPY (30a) which has already been mounted in the bay. (Fig. A5.04b)
- Place the Toe Board UPY (30) on the second tube and simultaneously insert it into the trapezoid box (30.6) of the toe board in the corner bay.
- Lower the toe boards simultaneously.
→ The toe board is installed. (Fig. A5.04c)



When installing the Toe Boards UPY at the corner, make sure that the slot is always aligned with the slot (30.2) or the hole with the hole (30.4). (Fig. A5.05a/A5.05b)

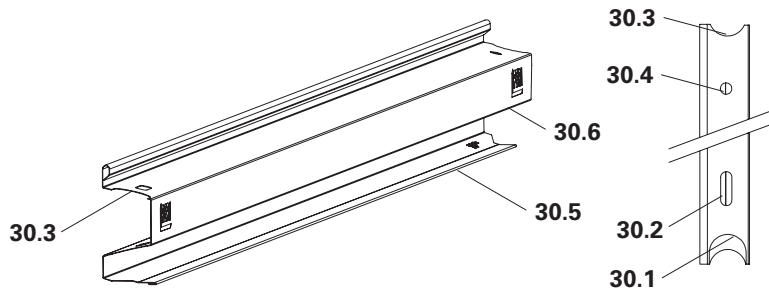

Fig. A5.03

Fig. A5.03a

Right corner

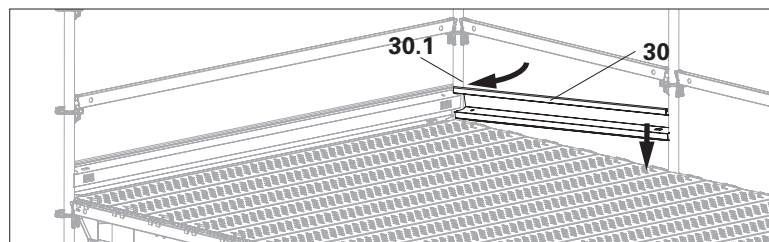

Fig. A5.04a

Left corner

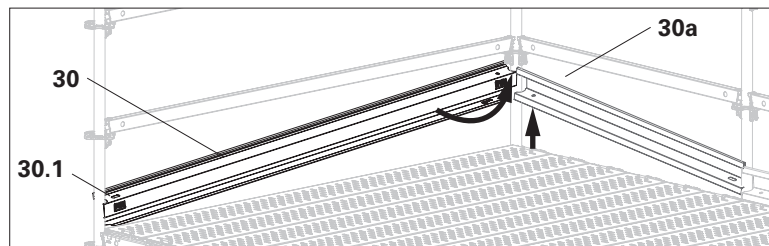

Fig. A5.04b

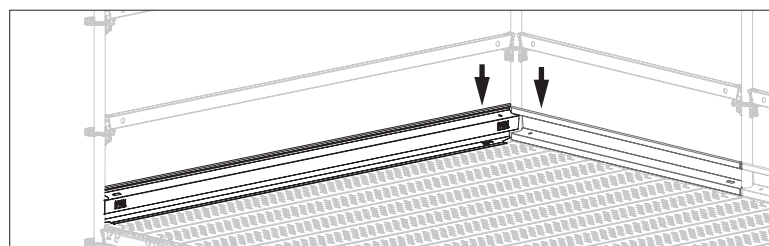

Fig. A5.04c

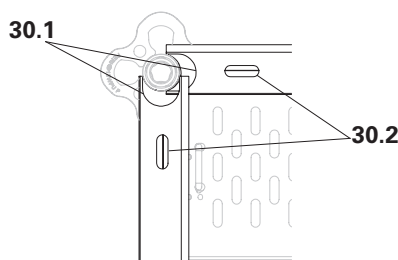

Fig. A5.05a

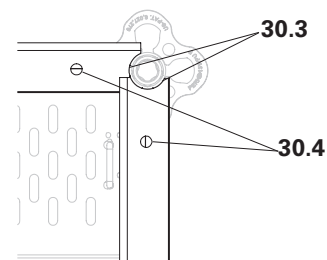

Fig. A5.05b

Toe Board Compensation UPY-L

With the Toe Board Compensation UPY-L (31) and two Toe Boards UPY (30), it is possible to fit a Toe Board that is continuously adjustable in terms of its length. (Fig. A5.06)

Toe Boards with different lengths may be used.

Technical data

- Maximum length: 5.00 m
- Overlap
 - up to length 1 m: L = 20 cm
 - length of 1 m and higher: L = 50 cm

Assembly

1. Slide the Toe Board Compensation UPY-L (31) onto the first Toe Board UPY (30). (Fig. A5.06a)
2. Slide the second Toe Board UPY (30) between the Toe Board UPY and Toe Board Compensation UPY-L in an overlapping position.
3. Pull the boards to the required length between the verticals of the compensation bay.
4. Align the Toe Board Compensation UPY-L centrally at the overlap.
5. Tighten the wing nut.
 - The toe board is installed. (Fig. A5.06b)



For distances less than 25 cm, screw a wooden board to the inside of the toe boards. Use the existing screw holes in the toe boards. (Fig. A5.06c)
Alternatively, close the gap elsewhere on site.

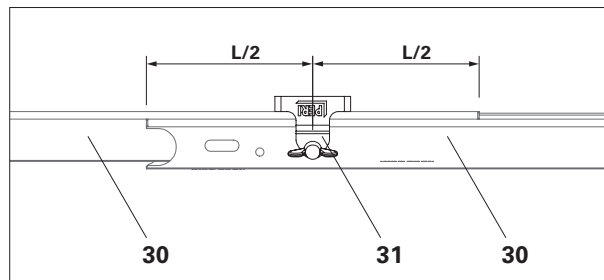

Fig. A5.06

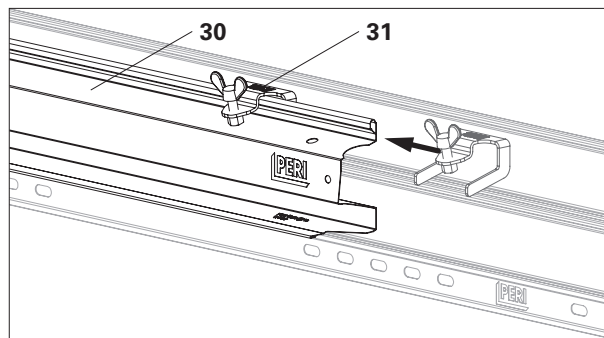

Fig. A5.06a

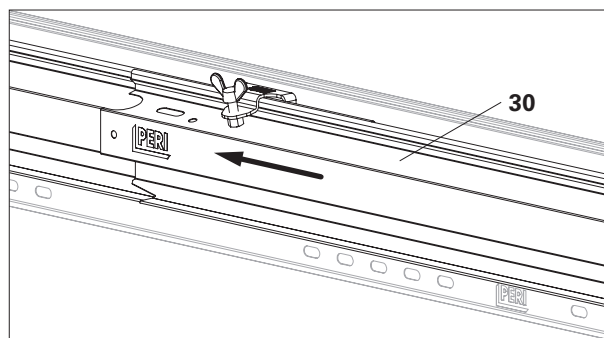

Fig. A5.06b

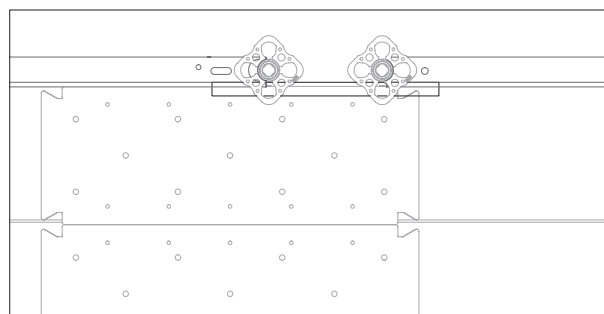

Fig. A5.06c

Toe Board UPF



- In strong winds, additionally secure the Toe Boards UPF using suitable means.
- Toe Boards UPF are correctly installed when each PERI logo is legible.

Assembly

1. Place the Toe Board UPF(32) on one side with the end piece on the Standard UVR (12a).
2. Lower onto the deck.
3. Raise the other side so that the second end piece can be fitted onto the second standard (12b).

(Fig. A5.07a)

4. Lower the toe board onto the deck.
- The toe board is now installed.

(Fig. A5.07b)

Assembly at corners

In the case of an all-round closed shape, raise the meeting toe board sides and lower them together.



- Installation is done in the same way on all standards.
 - For corners, turn the toe boards so that the retaining lugs (32.2) of the end pieces engage with each other.
- (Fig. A5.07c)

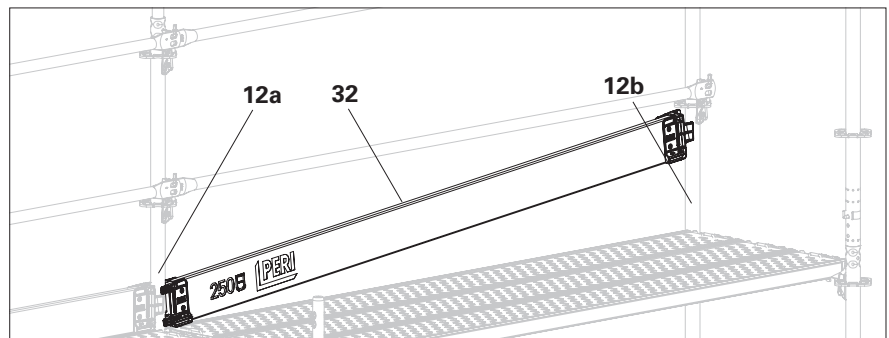

Fig. A5.07a

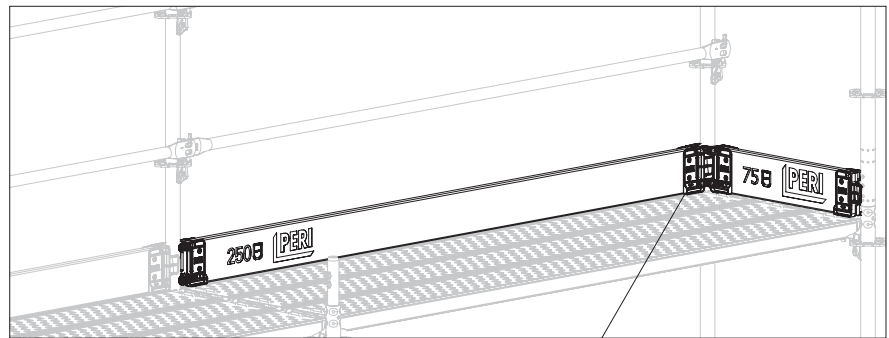

Fig. A5.07b

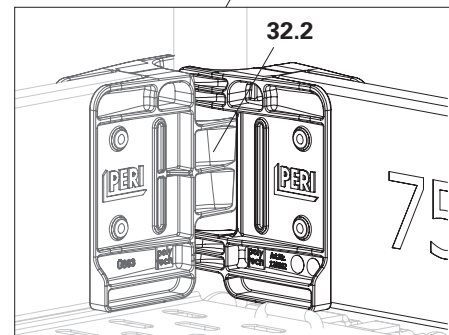

Fig. A5.07c

Guardrail Post EPG

Guardrail post assembly

For assembly of the Guardrail Holder EPW see "Guardrail Holder EPW" on page 121.

1. Turn the connecting pieces (51.1) of the guardrail post horizontally and place them on the Guardrail Hook EPW. (Fig. A5.08a)
2. Align the slot (51.2) with the guardrail hook (16.1) and insert. (Fig. A5.08b)
3. Release the guardrail post.
 - The guardrail post drops into a vertical position and is secured.
 - Guardrail post is installed. (Fig. A5.08c)

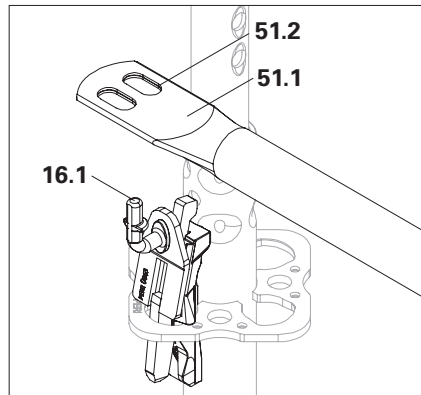

Fig. A5.08a

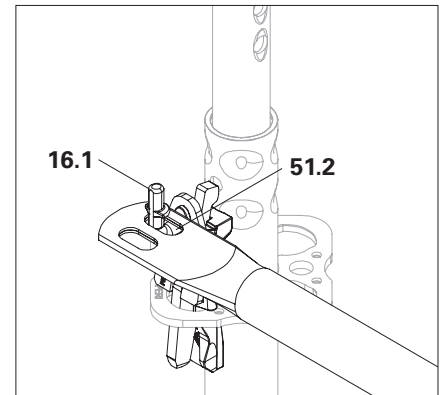

Fig. A5.08b

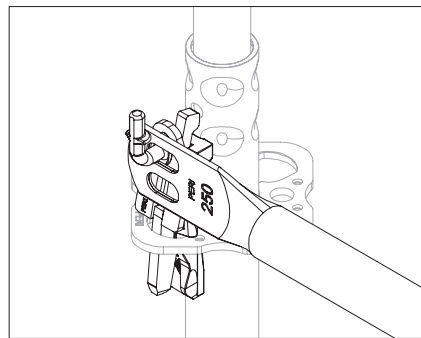

Fig. A5.08c



- For assembly and dismantling, first insert or detach one side, then the other side.
- The assembly can also be carried out "advanced" and "double-advanced" with guardrails and intermediate guardrails. (Fig. A5.09a + A5.09b)



Note

Stability compromised!

- ⇒ Do not attach any loads (e.g. materials) to the guardrails nor place any loads on the guardrail posts!

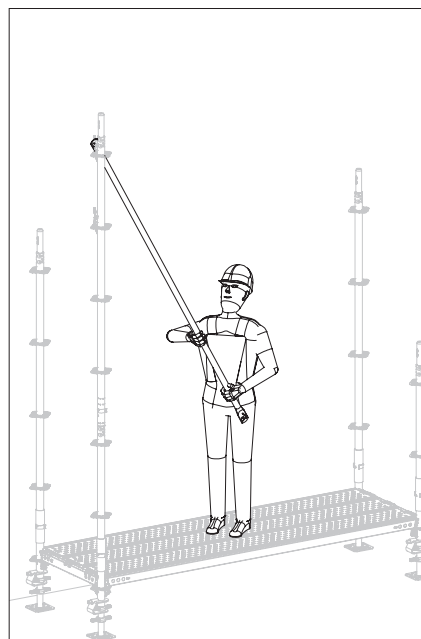

Fig. A5.09a

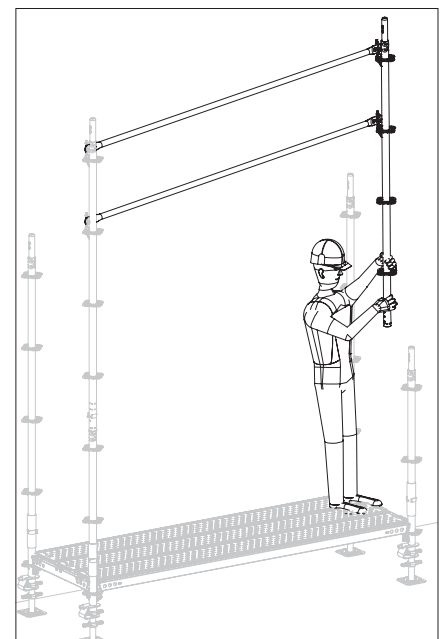

Fig. A5.09b

Swing Ledger UPK

Swing Ledgers UPK (34) are used to restrict access.
 Locked-off areas, e.g. access to freight lifts, cannot be entered accidentally.



- Swing ledgers must not be used as a structural component.
- During the installation of the swing ledger, other suitable risk prevention and protection measures must be taken to ensure safety.

Assembly

1. Hook the Swing Ledger UPK (34) on both standards (12) into the ledger-to-ledger couplers (12.2) of the rosettes.
2. Secure the wedges. (Fig. A5.11)
 → Swing ledger is installed.

Enter restricted area

1. Knock out the wedge on the swivel part. (Fig. A5.11a)
2. Fold the swivel part upwards, pass through and close the Swing Ledger UPK again.

Application examples

Barricading of danger zones that have to be entered occasionally.

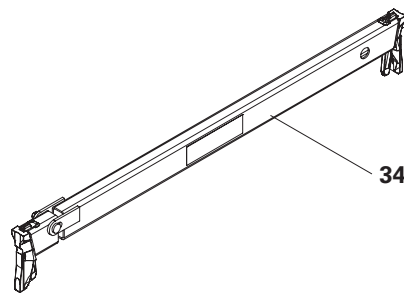

Fig. A5.10

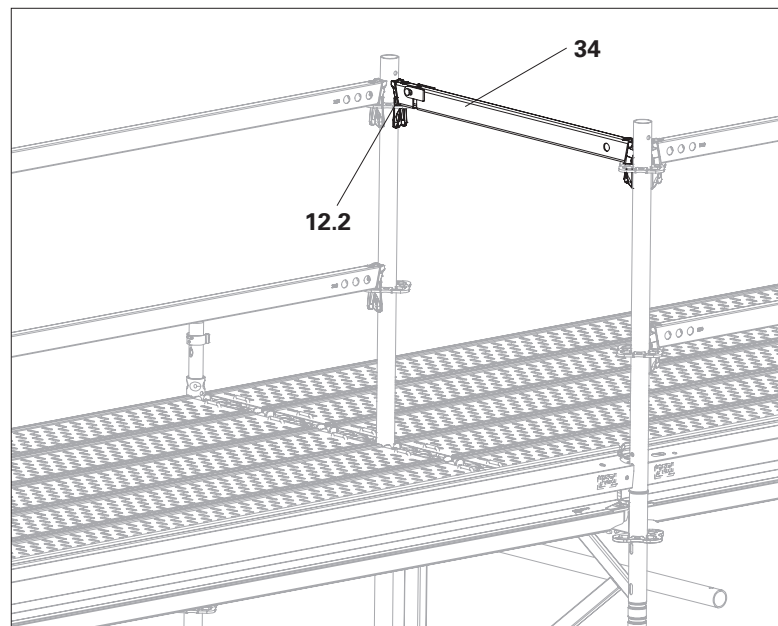

Fig. A5.11

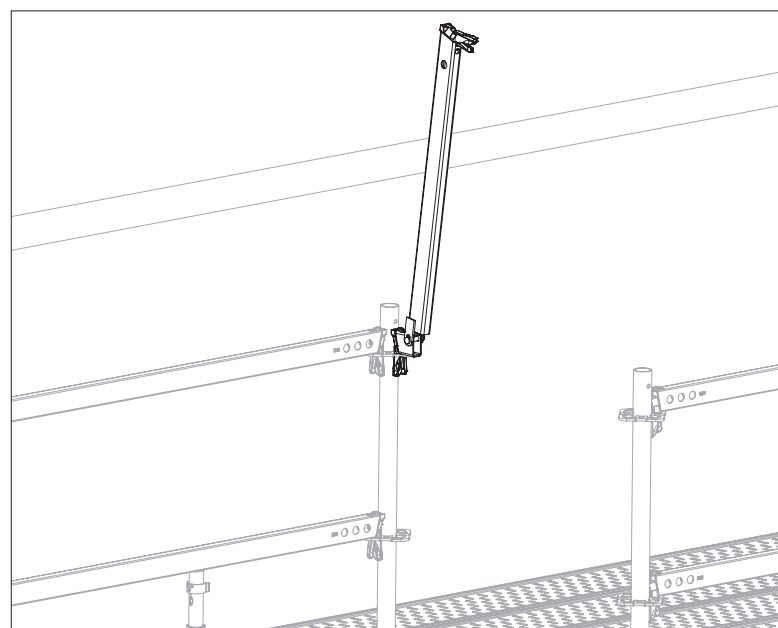

Fig. A5.11a

Safety Entry Gate UPS

Self-closing Safety Entry Gate UPS (35) as access to work areas.



- Always install the safety entry gate so that it only opens into the safe area.
- During the installation of the safety entry gate, other suitable measures must be taken to avert the respective danger.
- Safety entry gate must be securely supported by the striking plate (35.1) on the opposite standard.

Assembly

1. Install the safety entry gate with wedge (35.2) and suspension bracket (35.3) on the rosettes of the standard. (Fig. A5.12a – A5.12c)
 2. Secure the wedge.
 3. Check that the self-closing function works properly.
- Safety entry gate is installed.

Application examples

Safeguarding ladder access on working platforms.

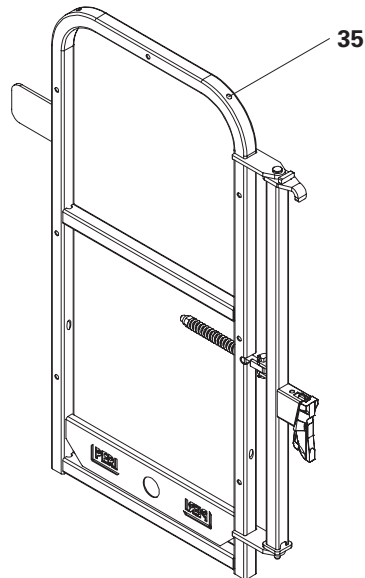

Fig. A5.12

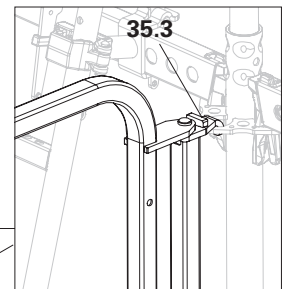

Fig. A5.12b

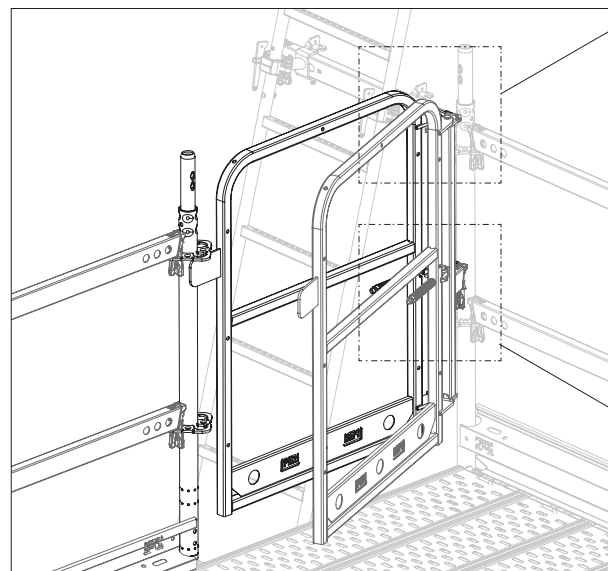

Fig. A5.12a

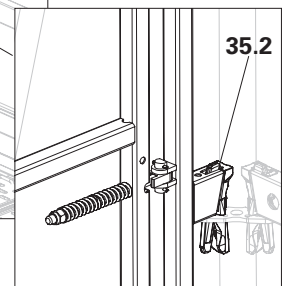

Fig. A5.12c

End Guardrail in Advance UPA-2

The End Guardrail in Advance UPA-2 (36) is installed continuously as a system-integrated end guardrail, from a secured position, for the next layer. It can remain on the scaffold for the entire duration of erection or be exchanged for another end protection.

Assembly

1. Suspend the end guardrail in advance (36) above the crossbar. The pegs (36.1) must point towards the outer side of the scaffolding. (Fig. A5.14a)
2. Reach around the outer standard (12a) with the outer hand and grasp the end guardrail in advance at the end of the tube.
3. Swing the end guardrail halfway down and hook the fork (36.2) onto the outer standard. (Fig. A5.14b)
4. Guide the inner hand with the end guardrail in advance around the inner standard (12b).
5. Raise the end guardrail in advance until the pegs (36.1) can be inserted into the rosettes (12.1) from above. (Fig. A5.14c)
6. Insert the peg (36.1) into the brace adapter (12.3) of the rosette and lower it to the stop. (Fig. A5.14d)
→ End Guardrail in Advance UPA-2 is installed.

Application examples

Facade, reinforcement, industrial scaffolding.

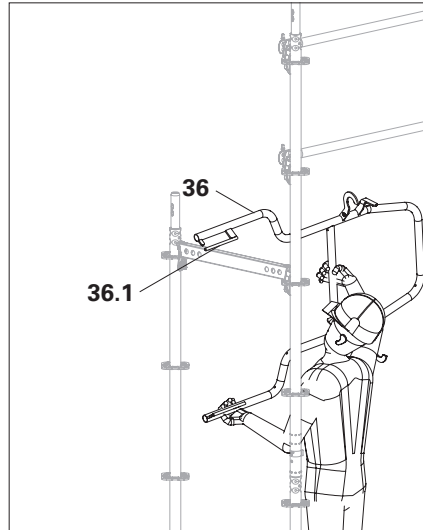

Fig. A5.14a

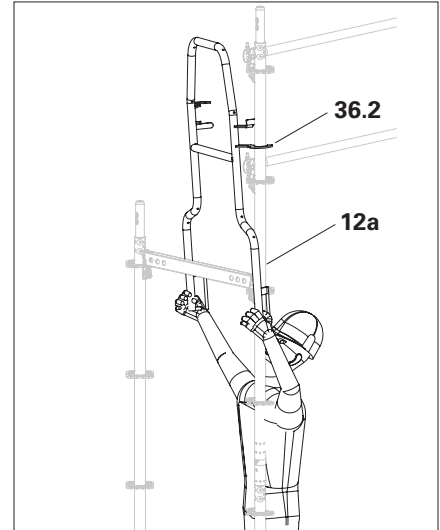

Fig. A5.14b

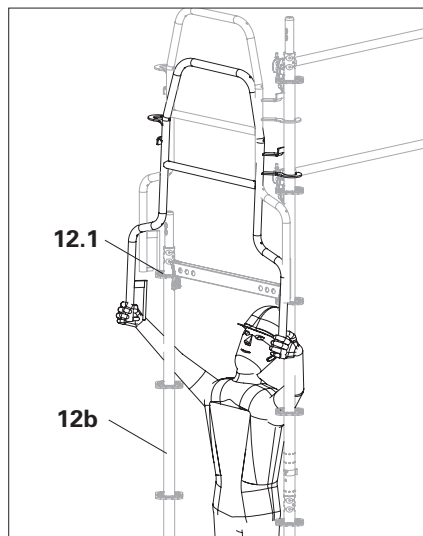

Fig. A5.14c

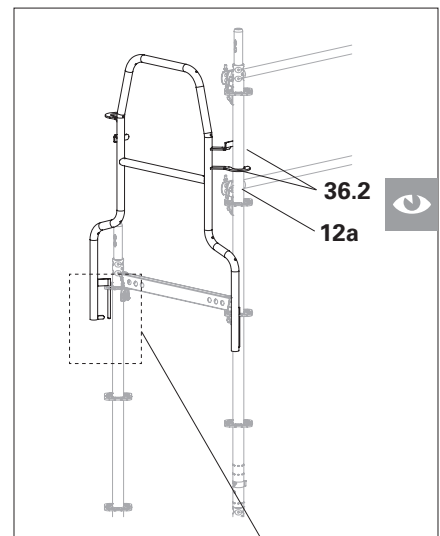
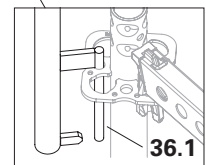
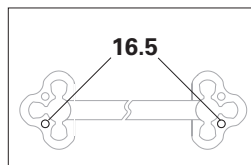

Fig. A5.14d



The End Guardrail UPA can also be installed on the inside. (Not in connection with attached console brackets with decks)



Does the fork (36.2) enclose the outer standard (12a)?

General

Console brackets (with spigots) and supports (without spigots) are available for PERI UP Flex.

If a guardrail post is required for lateral protection, use console brackets only.



- The addition of console brackets increases the requirements for anchoring and bracing. Observe the tie pattern of the respective system-specific Instructions for Assembly and Use, or provide static proof.
- The respective linear loads or the concentrated loads apply, see next page or the "PERI UP Design Tables".
- Observe the load classes of the decks, see the "PERI UP Design Tables".
- Console Brackets ECM and UCM cannot be mounted on the same rosette at a 90° angle.

Components

-
- 40 Support UC 25/33
 - 41 Console Bracket ECM
 - 33/50/67/75/100
 - 42 Console Bracket UCB 25
 - 43 Console Bracket UCM 50/75 with Semi-Rosette
 - 44 Console Bracket UCM 50/75 with Spigot
 - 45 Console Bracket UCM 50/75 -2
 - 46 Console Bracket Brace UCM
 - 47 Support UCS 33
-

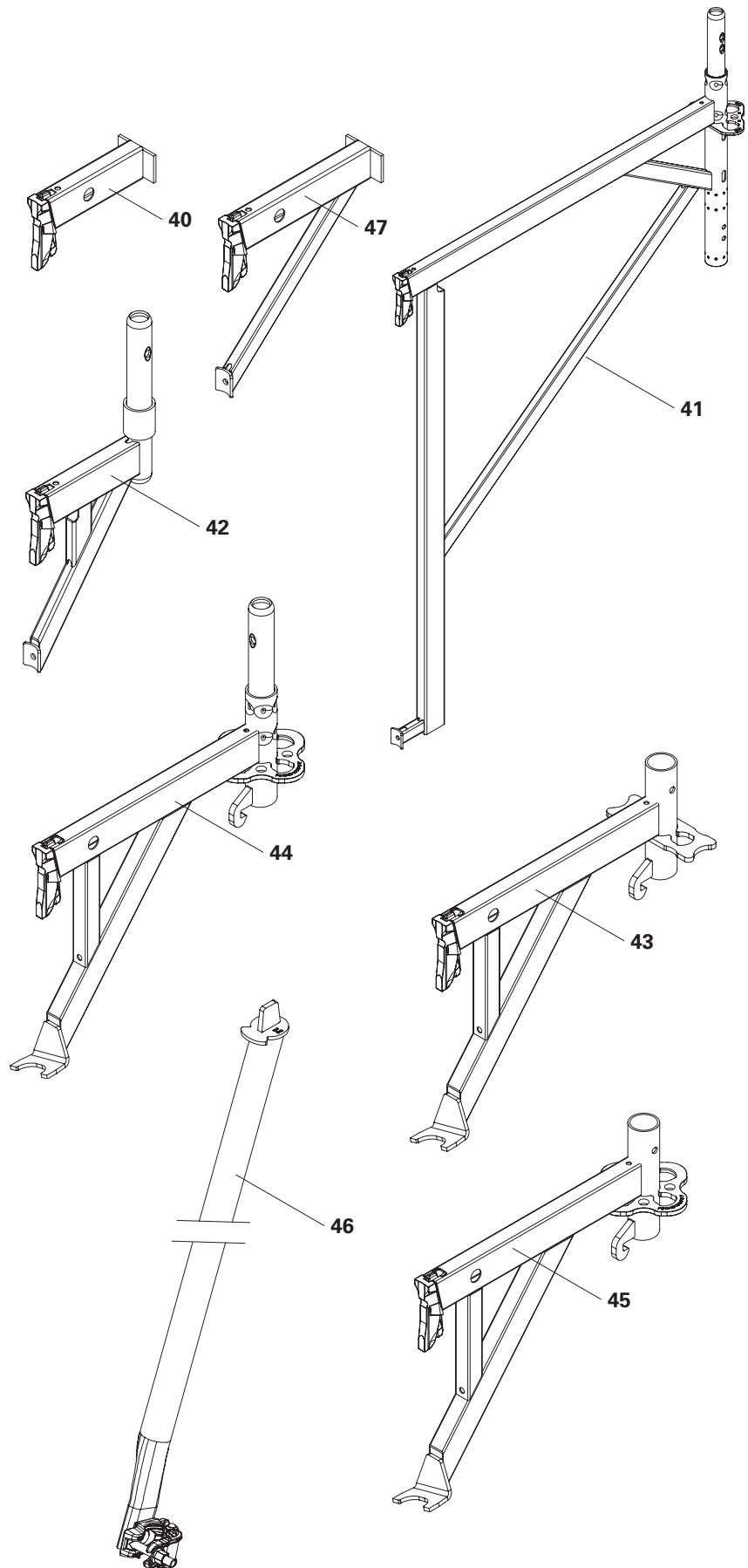

Load-bearing capacities

The adjacent tables show the permissible concentrated loads and line loads in the most unfavourable application. They can be used for arbitrarily configured superstructures, provided that the boundary conditions are observed.

Possibly higher permissible loads are described in the respective System Instructions for Assembly and Use, e.g. anchored facade scaffolds.



- A horizontal ledger (**14**) must be installed opposite the rosette, on which a console bracket is installed.
- If additional components are connected to the rosette, additional static proof for the maximum shoring load is required.
- When determining the max. individual load, the 1 m high lateral protection and the dead weight of the deck were taken into account.
- Maximum individual and line loads cannot be applied together.

Maximum concentrated loads F for console brackets [kN]				
	Vertical			
Support/Console bracket	UVR-2	UVR	UVH	EVT 96
ECM 33	3.55	4.00	4.00	4.00
ECM 50	2.80	3.90	3.90	3.72
ECM 67	2.60	3.62	3.62	3.43
ECM 75	2.20	3.15	3.15	2.93
ECM 100	1.68	2.13	2.13	1.95
UC 25	/	/	/	/
UC 33	/	/	/	/
UCB 25	4.55	6.17	6.17	6.10
UCM 50*	2.05	3.05	3.05	2.92
UCM 75*	1.20	1.90	1.90	1.80
UCM 50-2*	2.05	3.05	3.05	2.92
UCM 75-2*	1.20	1.90	1.90	1.80
UCS 33	/	/	/	/

Maximum line loads p for console brackets [kN/m]				
	Vertical			
Support/Console bracket	UVR-2	UVR	UVH	EVT 96
ECM 33	20.00	24.00	24.00	24.00
ECM 50	10.00	14.50	14.50	14.00
ECM 67	6.90	9.60	9.60	9.30
ECM 75	5.15	7.25	7.25	7.00
ECM 100	3.00	3.00	3.00	3.00
UC 25	24.00	31.50	31.50	31.50
UC 33	13.40	17.00	17.00	17.00
UCB 25	34.50	48.00	48.00	47.50
UCM 50*	7.80	11.70	11.70	11.50
UCM 75*	3.05	4.80	4.80	4.60
UCM 50-2*	7.80	11.70	11.70	11.50
UCM 75-2*	3.05	4.80	4.80	4.60
UCS 33	19.50	19.50	19.50	19.50

* without support.

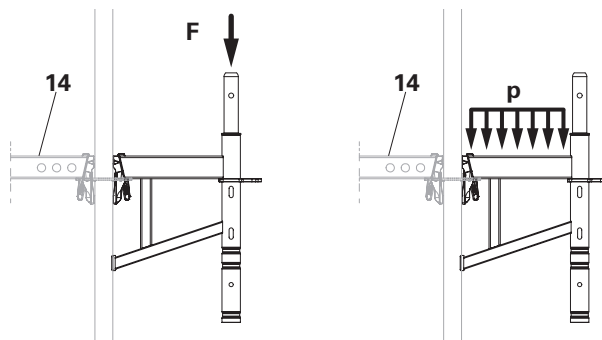

Fig. A6.01

Console bracket assembly



Console brackets are always installed from below!

The assembly procedure is shown using the Console Bracket ECM as an example. Other console brackets are installed in the same way.

Assembly

■ Console Bracket ECM 33/50

1. Hang the console bracket (**41a**) into the rosette of the standard or top standard at right angles to the scaffold. The formwork half (**41.1**) must rest against the vertical tube. (Fig. A6.02)

2. Secure the wedge.

→ The console bracket is now mounted. (A6.02a)

■ Console Bracket ECM 67/75/100

1. Hang the console bracket (**41b**) into the rosette of the standard or top standard parallel to the scaffold. (Fig. A6.03)

2. Hold the wedge (**41.2**) up, and swing the console bracket outwards. The formwork half (**41.1**) must rest against the vertical tube. (Fig. A6.03a)

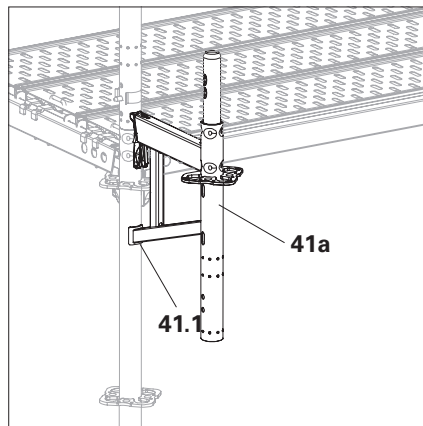

Fig. A6.02

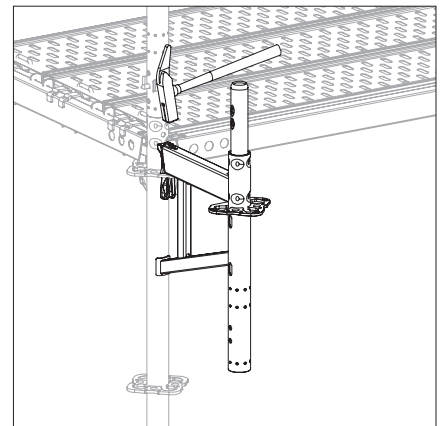

Fig. A6.02a

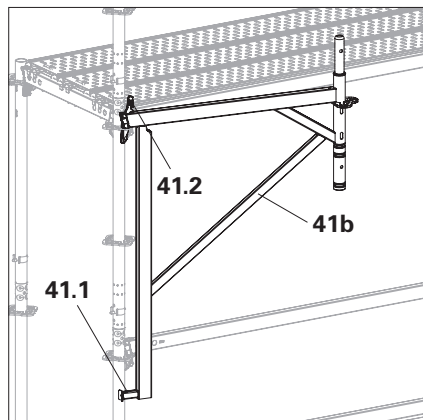

Fig. A6.03

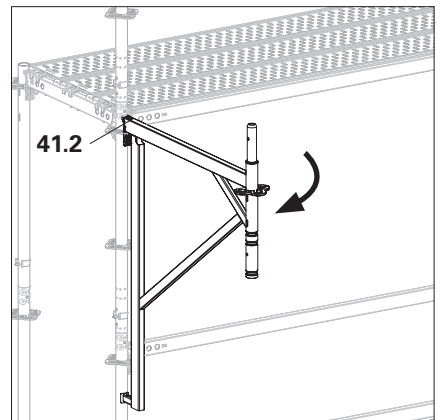

Fig. A6.03a

3. Drop the wedge into the rosette.
Secure the wedge.
→ The console bracket is now mounted.
(Fig. A6.03b)
4. Place the decks and push them
outwards. (not shown)

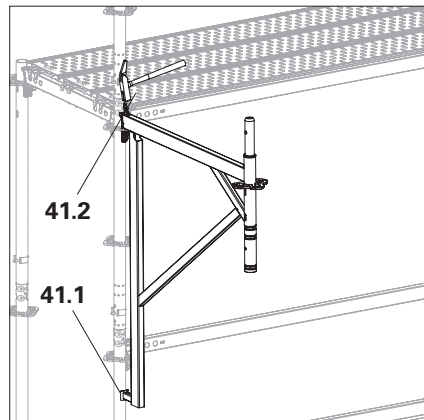

Fig. A6.03b

Console brackets with protection panel posts/ guardrail posts

Attach the Protection Panel Post EPS, Guardrail Post EVP, UVR Standard or UVH Top Standard to the scaffold before assembling the console bracket and assemble them together. Alternatively, installation of the protection panel posts and guardrail posts can also be done later after the console brackets have been mounted.

Installation of Guardrail Post EVP or UVR on console bracket

1. Before mounting, attach the Standard UVR (12) to the Console Bracket ECM (41).
2. To extend the reach, pin the standard with a locking pin \varnothing 48/57 (10).
3. The further assembly of the console brackets with the attached standard is done by swivelling them outwards as described previously.
(Fig. A6.04)

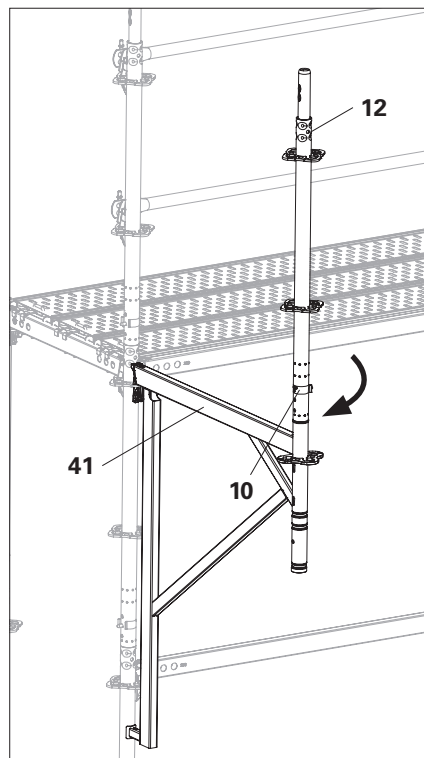

Fig. A6.04

Assembling the Protection Panel Post EPS on the console bracket

1. Slide the loop (37.1) of the Protection Panel Post EPS (37) onto the lower tube end of the console bracket (41). (Fig. A6.05a)
 2. Push the Protection Panel Post EPS upwards on the Console Bracket ECM and push it onto the spigot of the Console Bracket ECM until the hook block (37.2) engages in the ledger-to-ledger coupler of the rosette. (Fig. A6.05b + A6.05c)
 3. To extend the reach, pin the protection panel post with locking pins \varnothing 48/57 (10).
- The protection panel post is now pre-assembled. (Fig. A6.05c)

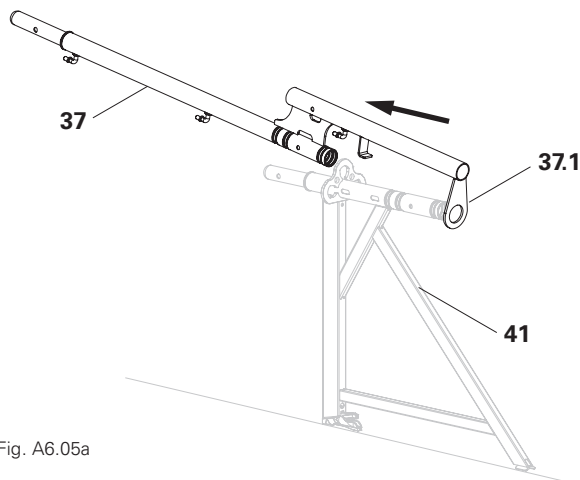

Fig. A6.05a

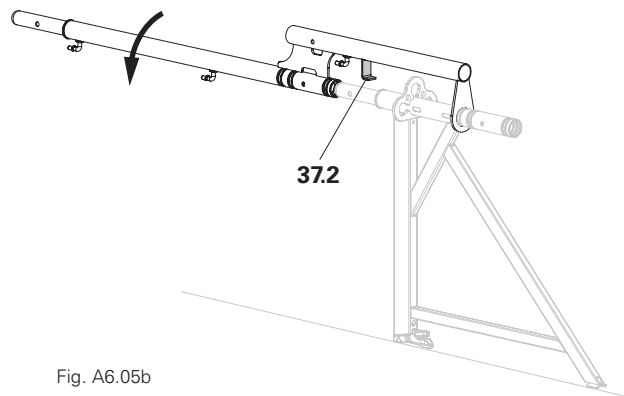

Fig. A6.05b

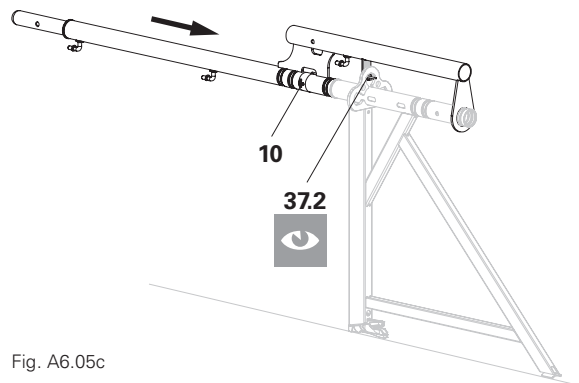

Fig. A6.05c



The hook block (37.2) must engage in the rosette!

Support UC 25/33 Support UCS 33

Supports UC (40) and UCS (47) do not allow the installation of a guardrail. Therefore, only use supports on the inner side of the scaffold.

Distance between deck surface and structure ≤ 30 cm. (Fig. A6.07b)

Always install a console bracket on the edge frame to attach front protection. (Fig. A6.07a)

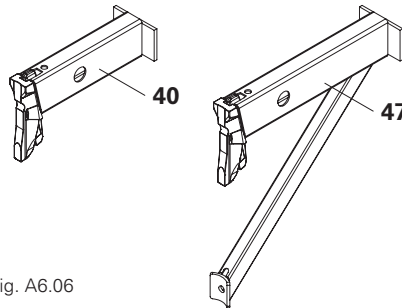

Fig. A6.06

Fig. A6.06a

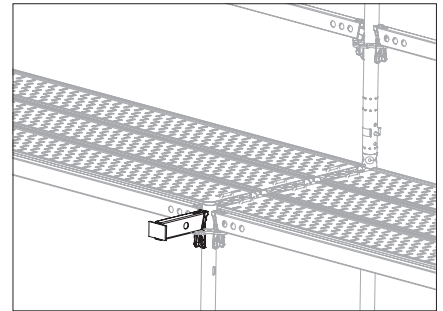

Fig. A6.06b

Assembly

1. Hook the support into the rosette's ledger-to-ledger coupler.
2. Secure the wedge.

Application example

Internal console brackets without lateral protection.

Console Bracket ECM

Available in widths of 33, 50, 67, 75 and 100 cm.

Console Bracket ECM (41) with spigot at the top for attaching a standard and spigot connection at the bottom for supporting on the console bracket below.

A Protection Panel Post EPS (37) can be attached to the console bracket. Console bracket brace is not required and not provided.

Edge frame hoist with Console Bracket UCB 25 or ECM 33

Centre frame hoist with Support UC 33/25

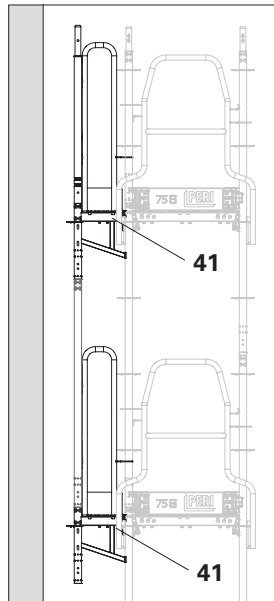

Fig. A6.07a

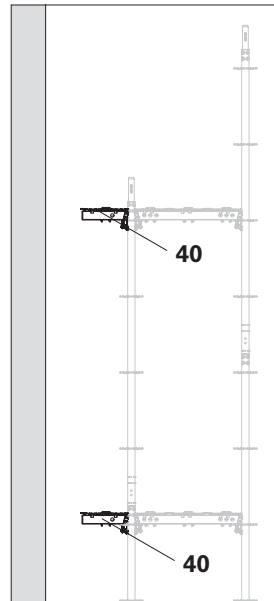

Fig. A6.07b

Application example

External console brackets as sheet metal walkway or roof catch.

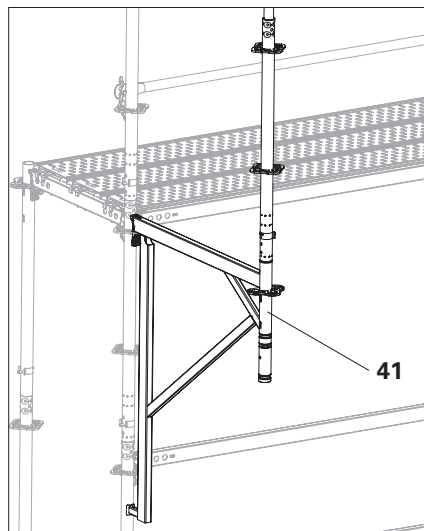

Fig. A6.07c

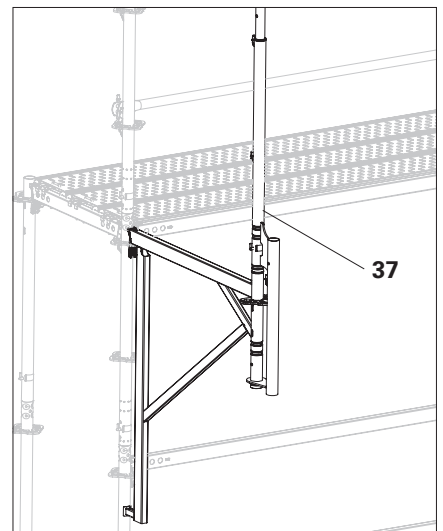

Fig. A6.07d

Coupled console brackets

Console Brackets ECM 33 (**41a**) can be coupled in series. This means that the scaffold width can be easily adjusted to the respective requirements at any time. (Fig. A6.08a + A6.08b)



Other combinations of console brackets and supports are possible, but the structural stability must be demonstrated for the specific project.

Edge frame hoist with Console Bracket ECM 33 (**41a**)

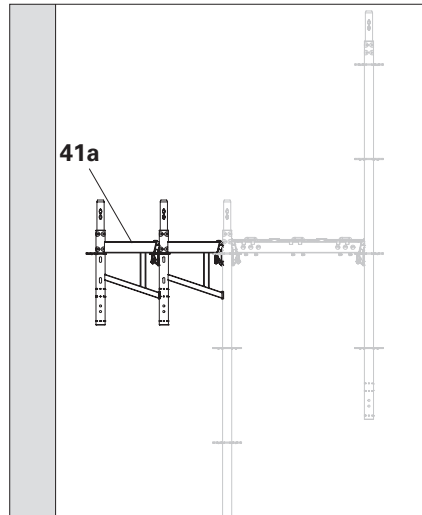

Fig. A6.08a

Centre frame hoist with Support UC 33 (**40a**)

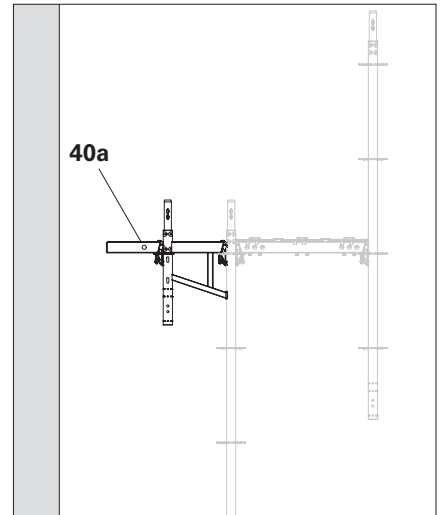

Fig. A6.08b

Lifting wind forces

Securing console brackets against lifting wind forces is generally not necessary. In individual cases, e.g. when using with a protection panel, secure the console brackets as follows. (See structural stability calculations for the project or system-specific Instructions for Assembly and Use.)

1. Fit Guardrail Coupling EPW (**92**) with lug (**92.2**) facing upwards. Nose must engage in the brace of the console bracket. (Fig. A6.09)

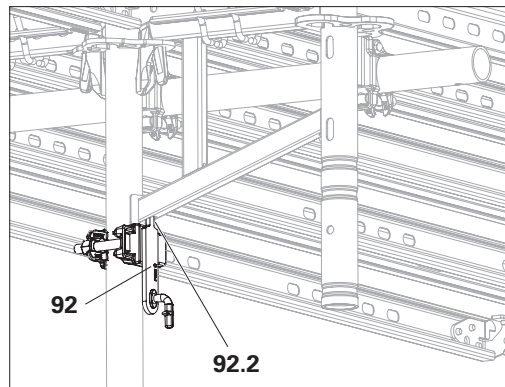

Fig. A6.09

Console Bracket UCB 25

Console Bracket UCB 25 (42) with Spigot, but without Rosette. Additional console brackets cannot be coupled, horizontal bracing with horizontal ledgers is not possible.

Application example

External or internal console brackets with lateral protection.

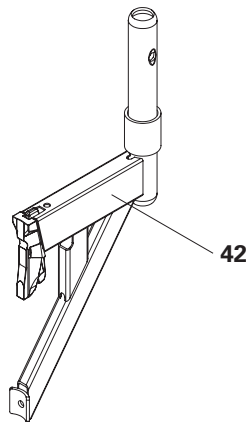

Fig. A6.10

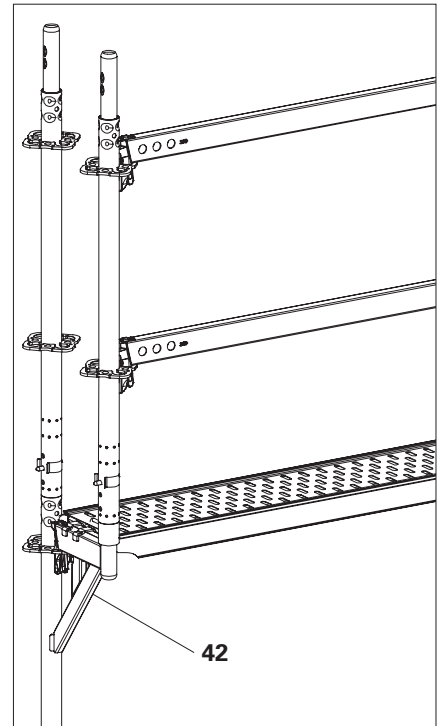

Fig. A6.10a

Console Bracket UCM

Console Brackets UCM are available in widths of 50 cm and 75 cm and in various finishes.

It is not possible to support the console bracket below in the system.

For increased load requirements, the Console Bracket Brace UCM (46) can be installed, see Section "Console Bracket Brace UCM" on page 74.

Console Bracket UCM (43) with Semi-Rosette

Console Bracket UCM with Spigot (44)
Console Bracket UCM 50-2 (45)

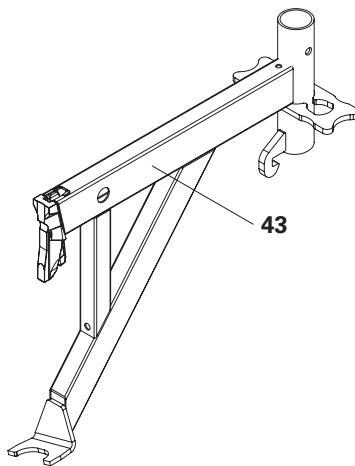

Fig. A6.11a

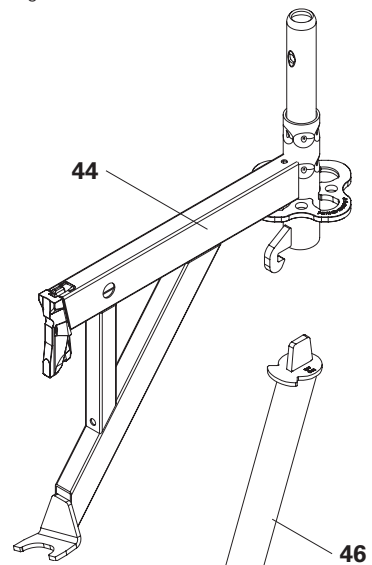

Fig. A6.11b

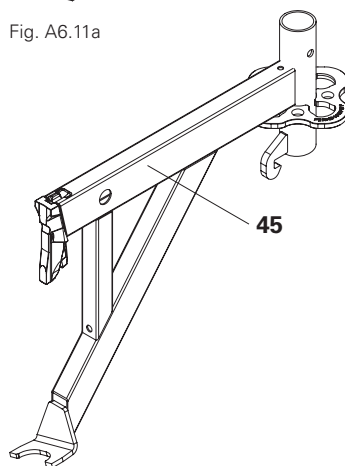

Fig. A6.11c

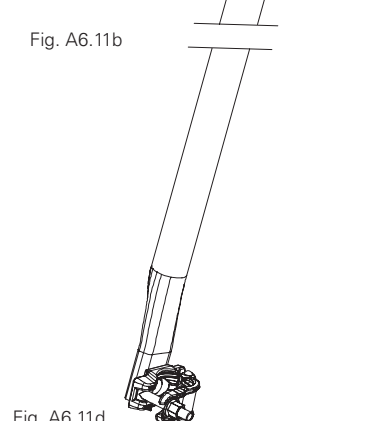

Fig. A6.11d

Console Bracket Brace UCM



- Assembly is only necessary with increased load requirements in conjunction with Console Bracket UCM, see "PERI UP Design Tables".
- Console bracket brace can also be retrofitted.

Assembly

1. Install Console Brackets UCM (43).
2. Open the tube coupling of the console bracket brace.
3. Insert bracket brace (46) with centring lug (46.1) from below into the console bracket tube. When doing so, bring the console bracket brace up to the console bracket tube at an angle of approx. 45°. (Fig. A6.12a + A6.12b)
4. Press the console bracket brace lightly against the console bracket tube and swing it into the console bracket axis – do not release it yet.



Is the anti-lift plate (46.2) held by the hook (43.9) of the console bracket? (Fig. A6.12c)

5. Place tube coupling (46.3) around standard, close and tighten screw with 50 Nm.
- Console bracket brace is installed. (Fig. A6.12d)

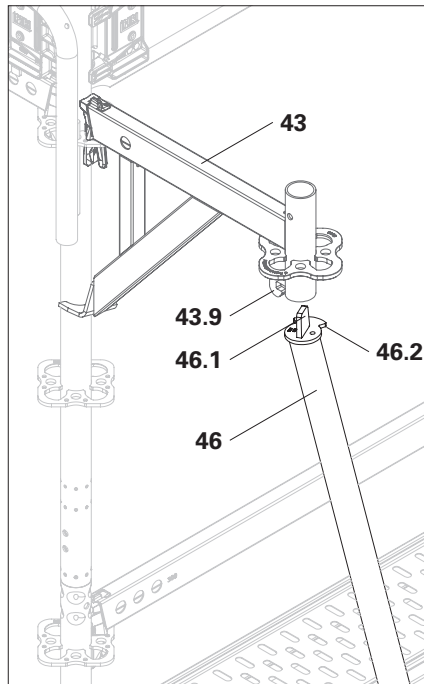

Fig. A6.12a

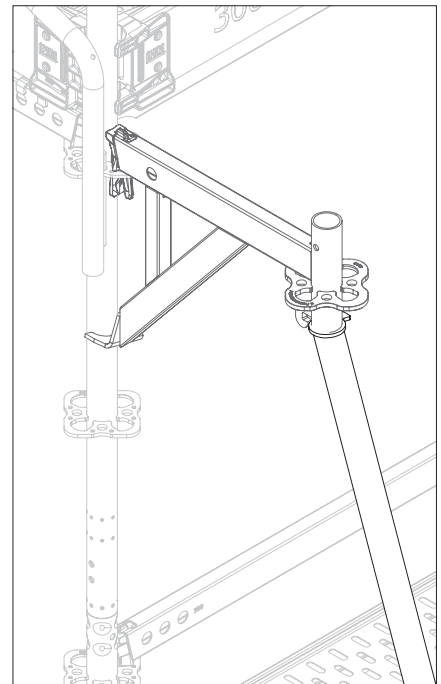

Fig. A6.12b

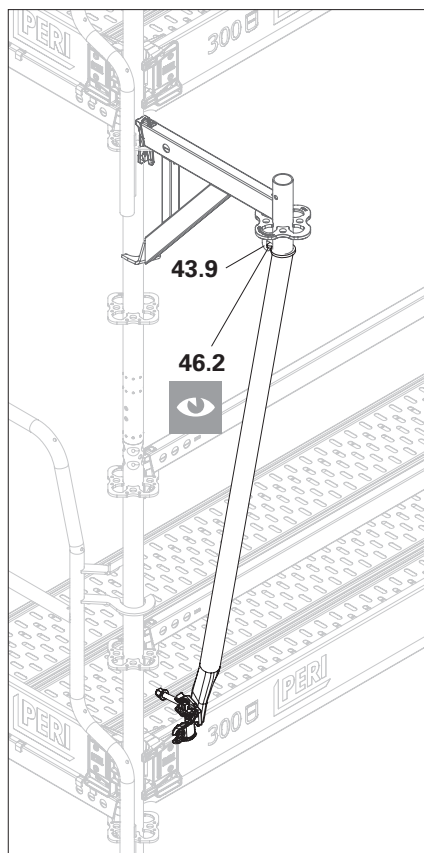

Fig. A6.12c

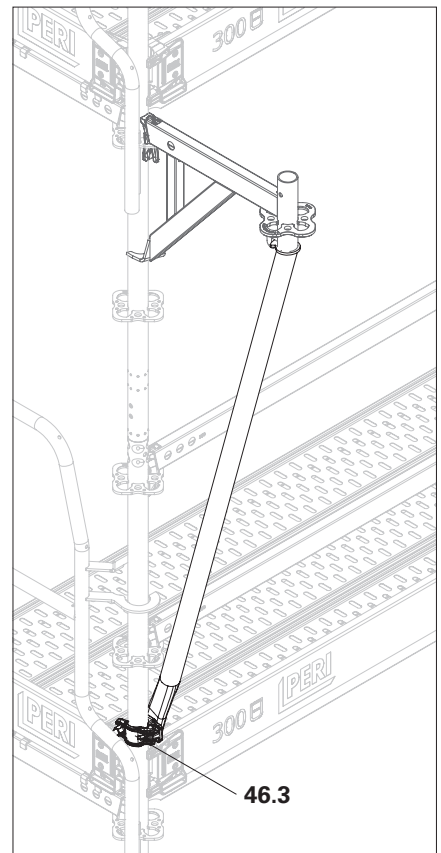

Fig. A6.12d

General

For PERI UP Flex, the deck is normally installed in a width grid of 25 cm. The Steel Deck EDS 33 from the PERI UP Easy system is compatible. All decks have integrated lift locks.



- System decks can be stiffening components. Missing system decks can therefore impair the stability of the assembly.
 - Observe the applicable system-specific Instructions for Assembly and Use.
- Before installing the decks and plates, check the load-bearing capacity for the intended use defined in the certificate of use. For load classes of the decks see "PERI UP Design Tables".

Components

-
- 50** Steel Deck UDG-2
 - 51** Inside Corner Plate EDP 25/33
 - 52** Cover Plate UDP 67/75/100
 - 53** Corner Plate UDC 50/75/100
 - 55** Steel Deck EDS
-

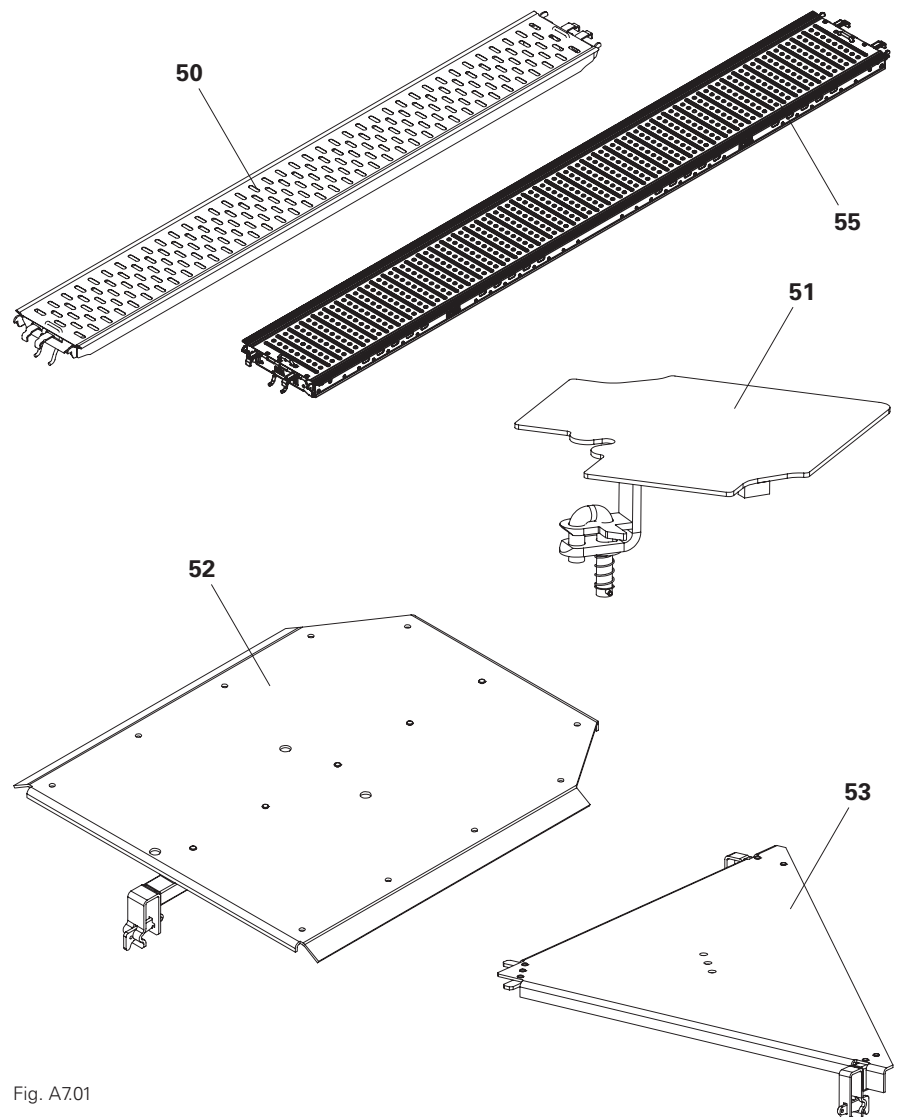

Fig. A7.01

Steel Deck UDG-2



The Steel Deck UDG-2 is shown as an installation example. The installation of further decks as well as the access decks and passage decks in the following Section is identical.

Assembly

1. Pick up the deck (50) in the middle and lift it over both horizontal ledgers (14).
2. Place the deck on the horizontal ledgers one after the other.
3. Lift locks (50.1) fall under the horizontal ledger and secure the deck.
→ The deck is now installed.
4. Edge the last deck in the scaffolding bay to the side for lifting.



Have all lift locks (50.1) fallen below the horizontal ledger? Bracket (50.2) must be flush with the deck. (Fig. A7.02d) If not, lift the deck slightly and let it drop into position or operate the lift lock manually.

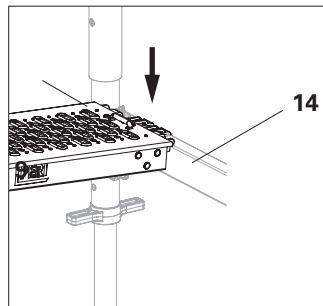

Fig. A7.02a

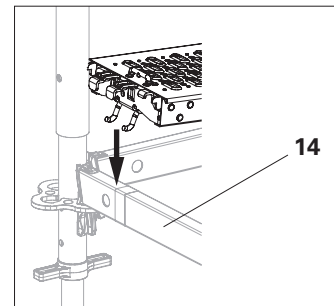

Fig. A7.02b

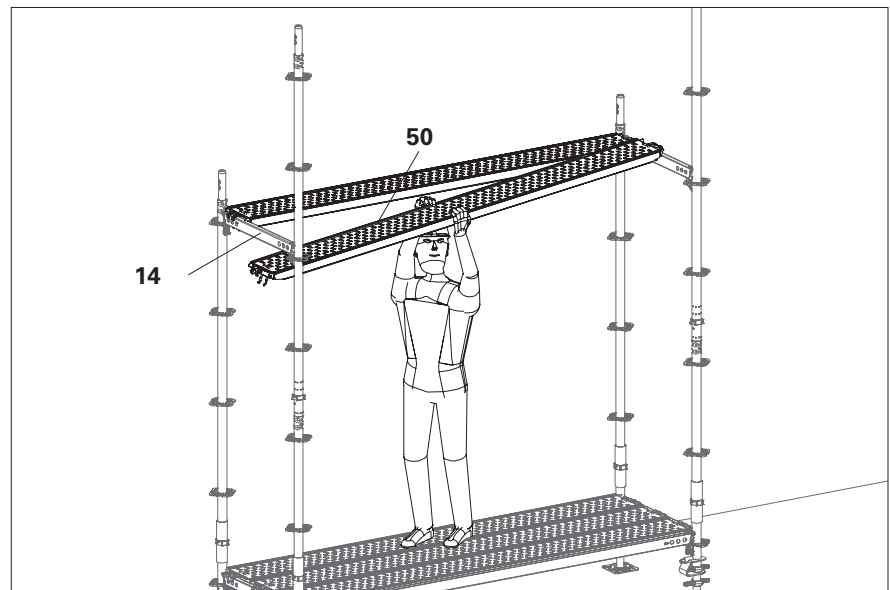

Fig. A7.02

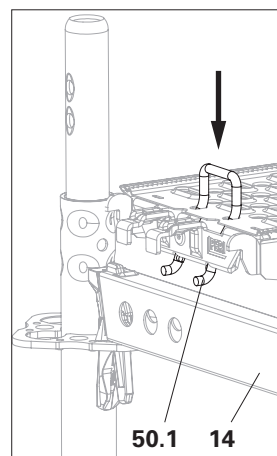

Fig. A7.02c

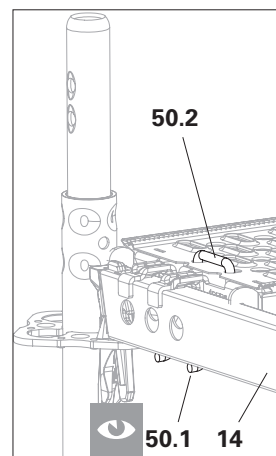

Fig. A7.02d

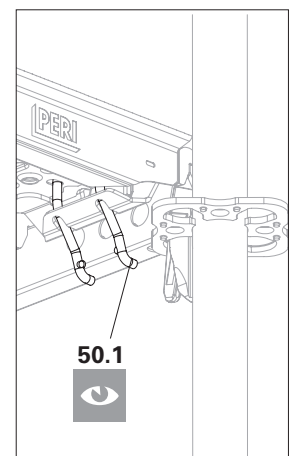

Fig. A7.02e

Comparison of components

As part of ongoing product optimisation, the following components have been replaced by 2nd generation components.

The following comparison tables describe the features of the 1st and 2nd generation.



1st and 2nd generation components can be combined.

- The previous components are no longer available as new components.
- The optimised components are available under a new article number.
- There may be a difference between the load-bearing capacity of the individual components in the previous version and the new version.

Steel Deck UDG

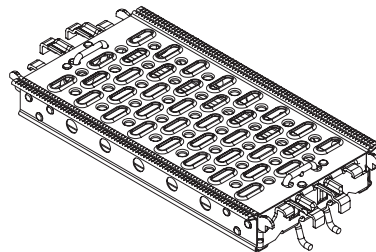

Steel Deck UDG-2

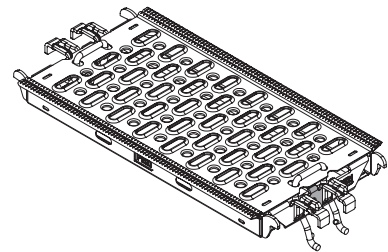

Deck assembly	Riveted and welded	Welded	
Profile height	65 mm, uniform	L 50 – 150	45 mm
		L 200 – 250	60 mm
		L 300	70 mm
Marking	without	Coloured clip on the front side	
Feature	Round holes in the bar	Slots in the bar	
Combinability	Geometrically and statically combinable in the system.		

Steel Deck EDS

Installation is carried out in the same way as for Steel Deck UDG-2 (50).

Steel Deck EDS (55) is suitable for scaffold widths in full metres due to its construction width of 33 cm.

Mixing

In the longitudinal direction, mixed joints of Steel Deck UDG-2 and Steel Deck EDS are not possible, as the hooks would overlap. (Fig. A7.03a)

Mixing within a bay is possible. This allows even more precise adjustments at interference points. Adjacent bays must be taken into account. (Fig. A7.03b)

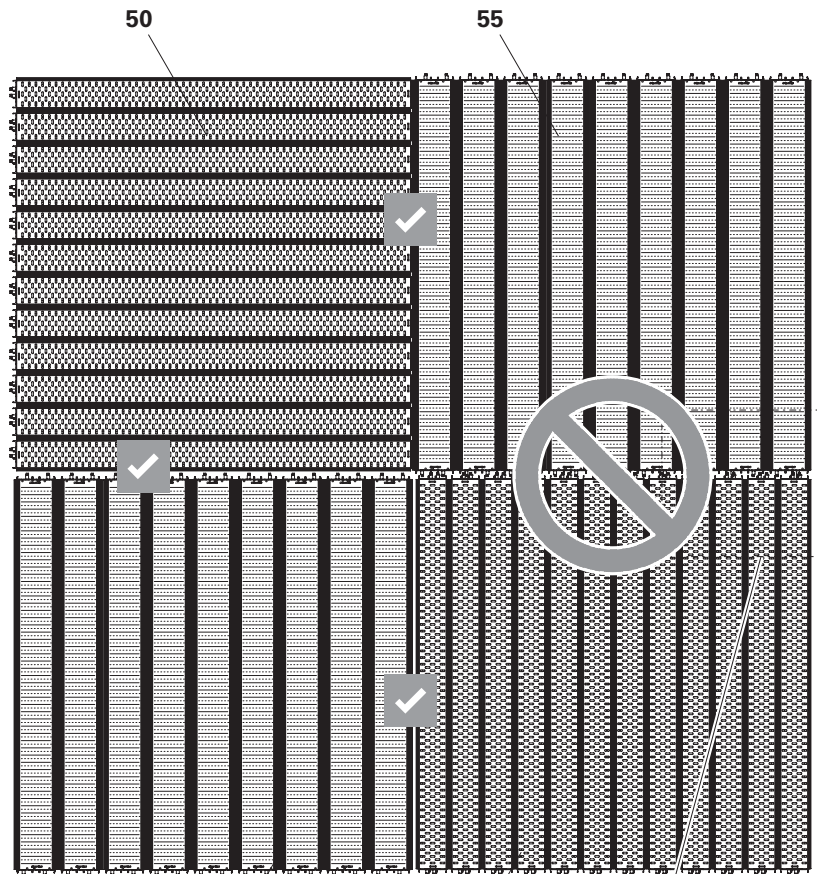

Fig. A7.03a

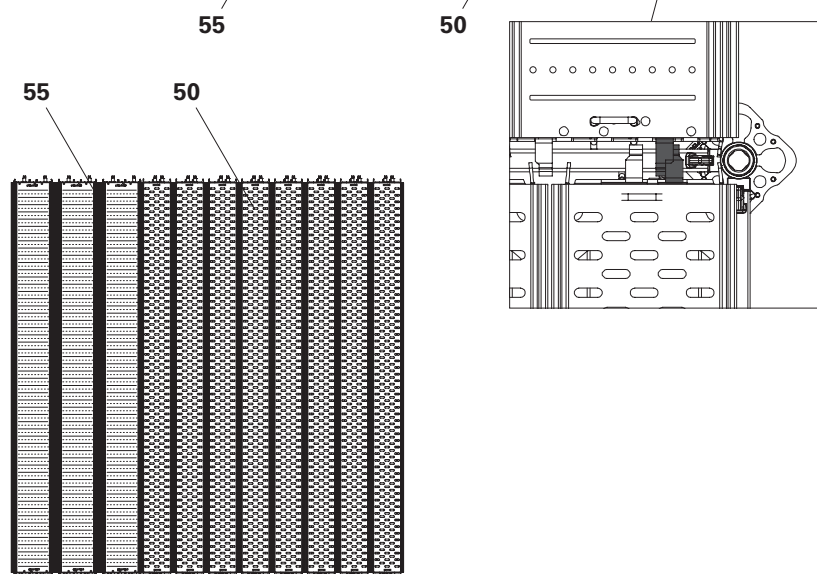

Fig. A7.03b

If Steel Decks UDG and EDS are used within a system in the longitudinal direction, a transition area must be installed. (Fig. A7.03c)

Installation example

1. In the last bay in which Steel Deck UDG-2 is installed, install two horizontal ledgers (**14**) in bay length.
2. Install a Horizontal Ledger (**14a**) on 2 Ledger-to-Ledger Couplers UHA (**93**). Distance to frame column 50 cm. (Fig. A7.03c) Do not tighten the wedges yet.
3. In this bay, install the Decks UDG-2 (**50**) 50 cm shorter than the bay length, e.g. 250 cm instead of 300 cm.
4. If necessary, correct the installation position of the horizontal ledger (**14a**) and hammer the wedges in tightly.
5. Close the remaining gap with 2 Steel Decks UDG-2 100 (**50a**) mounted crosswise.
6. Install Decks EDS (**55**) in the following bay. (Fig. A7.03d)

Alternatively:

Fit short, transverse Decks EDS.

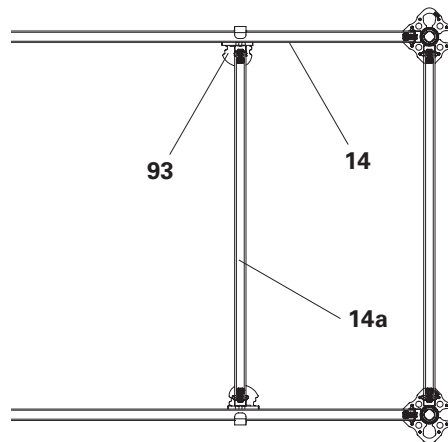

Fig. A7.03c

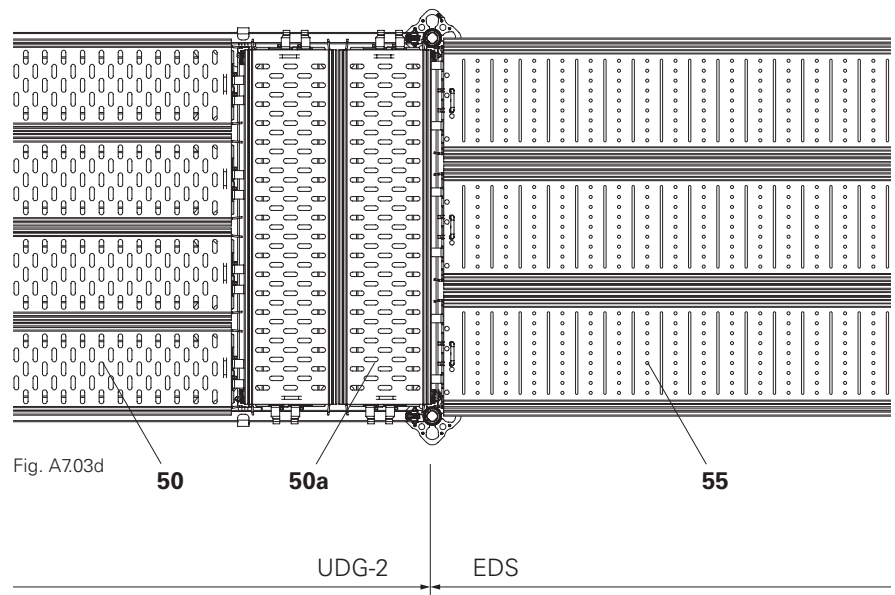

Fig. A7.03d

Deck Traverse UDT

The deck traverse can be used to create deck openings, e.g. for pipelines. Deck traverses are available in lengths of 25, 50 and 75 cm.



- The attachment of the deck traverse increases the requirements of the decks used as a support.
- Observe the load classes of the decks, see the "PERI UP Design Tables".
- The position of the recess can be freely selected. Refer to Table A7.01 for the max. possible loads.

Components

165 Deck Traverse UDT 25/50/75

Assembly

- The assembly is done from a secured position from below.
1. Turn the deck traverse to the head side so that the grips (**165.1**) of the drop ledger (**165.2**) protrude. (Fig. A7.04a)
 2. Take hold of the deck traverse at the grips and turn back into the installation position.
 3. At the intended position, lift the deck traverse into the deck gap diagonally from below and swing it in at right angles onto the adjacent decks. (Fig. A7.04b)
 4. Release the grips.
 - The drop ledgers (**165.2**) engage behind the deck edges and secure the deck traverse.
 - The deck traverse is installed.
 5. Install the decks. (Fig. A7.04c)

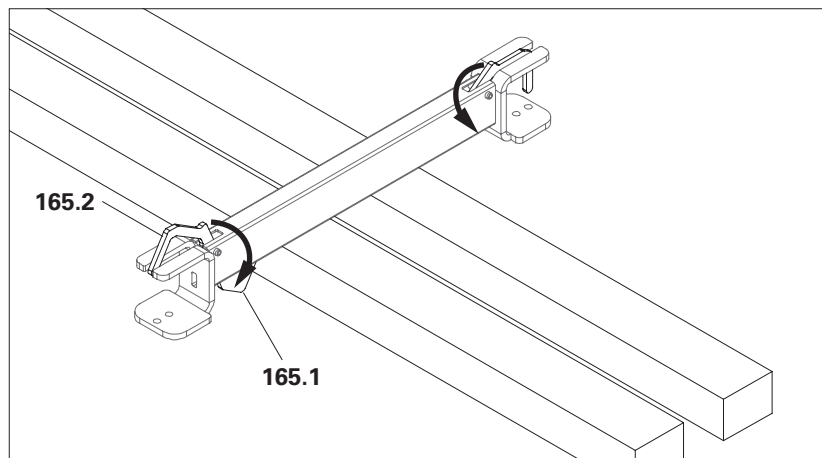

Fig. A7.04a

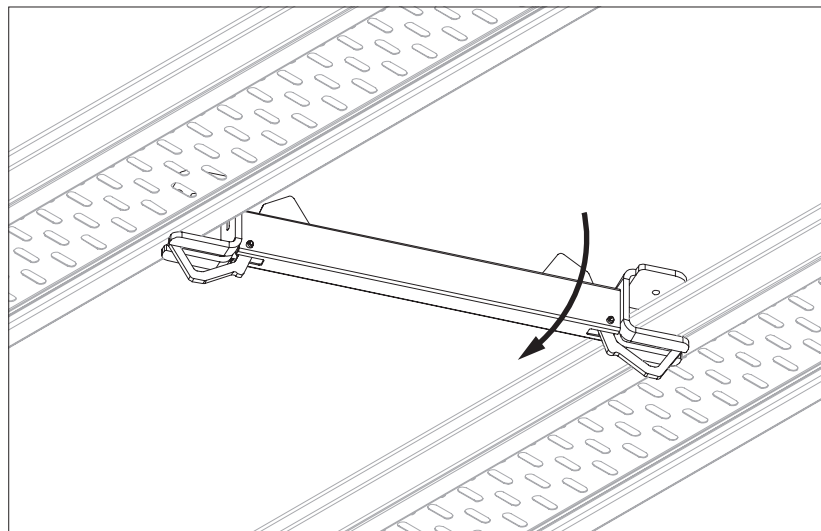

Fig. A7.04b

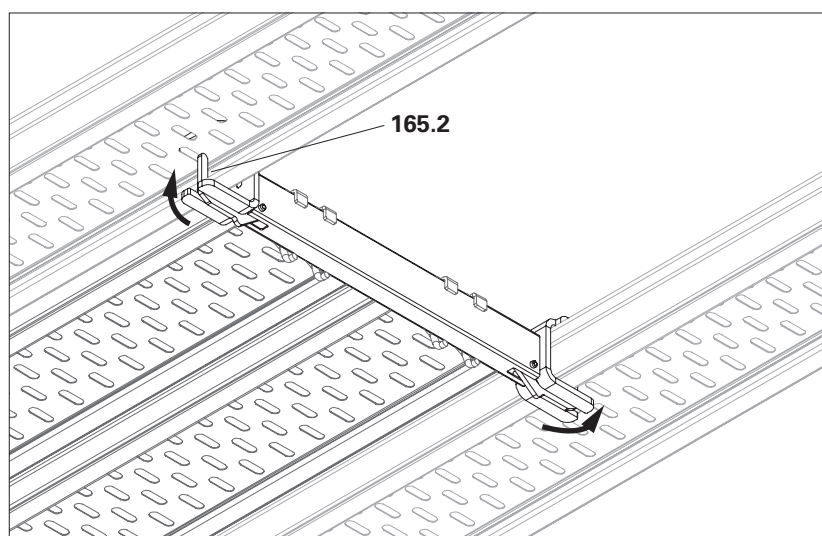
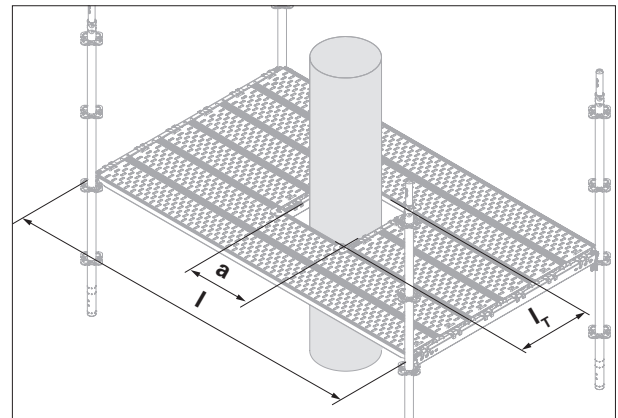

Fig. A7.04c



The table is only valid for the installation situation shown. For any other traverse application, and/or other load requirements, separate static verifications must be carried out for the traverse itself as well as for the load-bearing components.



Possible live load q_k in the illustrated installation situation

Deck series	Beam length l_T	Length Deck bay l	Recess length a [cm]								
			25	50	75	100	125	150	175	200	
UDI UDG UDG-2	25	150									
		200	3 kN/m ²	3 kN/m ²	3 kN/m ²	3 kN/m ²	3 kN/m ²	3 kN/m ²	3 kN/m ²	3 kN/m ²	
		250	3 kN/m ²	3 kN/m ²	3 kN/m ²	3 kN/m ²	3 kN/m ²	3 kN/m ²	3 kN/m ²	3 kN/m ²	
		300	3 kN/m ²	3 kN/m ²	3 kN/m ²	3 kN/m ²	3 kN/m ²	3 kN/m ²	3 kN/m ²	3 kN/m ²	

UDI	50	150	3 kN/m ²	3 kN/m ²	-	-	-	-	-	-
		200	3 kN/m ²	3 kN/m ²	3 kN/m ²	3 kN/m ²	-	-	-	-
		250	3 kN/m ²	3 kN/m ²	3 kN/m ²	3 kN/m ²	3 kN/m ²	3 kN/m ²	-	-
		300	3 kN/m ²	3 kN/m ²	3 kN/m ²	3 kN/m ²	3 kN/m ²	3 kN/m ²	3 kN/m ²	3 kN/m ²
	75	150	3 kN/m ²	3 kN/m ²	-	-	-	-	-	-
		200	3 kN/m ²	3 kN/m ²	3 kN/m ²	3 kN/m ²	-	-	-	-
		250	3 kN/m ²	3 kN/m ²	3 kN/m ²	3 kN/m ²	3 kN/m ²	3 kN/m ²	-	-
		300	2 kN/m ²	2 kN/m ²	3 kN/m ²	3 kN/m ²	3 kN/m ²	3 kN/m ²	3 kN/m ²	3 kN/m ²

UDG	50	150	3 kN/m ²	3 kN/m ²	-	-	-	-	-	-
		200	3 kN/m ²	3 kN/m ²	3 kN/m ²	3 kN/m ²	-	-	-	-
		250	2 kN/m ²	3 kN/m ²	3 kN/m ²	3 kN/m ²	3 kN/m ²	3 kN/m ²	-	-
		300	2 kN/m ²	2 kN/m ²	2 kN/m ²	2 kN/m ²	3 kN/m ²	3 kN/m ²	3 kN/m ²	3 kN/m ²
	75	150	3 kN/m ²	3 kN/m ²	-	-	-	-	-	-
		200	3 kN/m ²	3 kN/m ²	3 kN/m ²	3 kN/m ²	-	-	-	-
		250	2 kN/m ²	2 kN/m ²	2 kN/m ²	3 kN/m ²	3 kN/m ²	3 kN/m ²	-	-
		300	2 kN/m ²	2 kN/m ²	2 kN/m ²	2 kN/m ²	2 kN/m ²	3 kN/m ²	3 kN/m ²	3 kN/m ²

UDG-2	50	150	3 kN/m ²	3 kN/m ²	-	-	-	-	-	-
		200	3 kN/m ²	3 kN/m ²	3 kN/m ²	3 kN/m ²	-	-	-	-
		250	3 kN/m ²	3 kN/m ²	3 kN/m ²	3 kN/m ²	3 kN/m ²	3 kN/m ²	-	-
		300	2 kN/m ²	3 kN/m ²	3 kN/m ²	3 kN/m ²	3 kN/m ²	3 kN/m ²	3 kN/m ²	3 kN/m ²
	75	150	3 kN/m ²	3 kN/m ²	-	-	-	-	-	-
		200	3 kN/m ²	3 kN/m ²	3 kN/m ²	3 kN/m ²	-	-	-	-
		250	2 kN/m ²	2 kN/m ²	2 kN/m ²	3 kN/m ²	3 kN/m ²	3 kN/m ²	-	-
		300	2 kN/m ²	2 kN/m ²	2 kN/m ²	2 kN/m ²	3 kN/m ²	3 kN/m ²	3 kN/m ²	3 kN/m ²

Cover Plate UDB

Cover plates are used for the bridging of longitudinal infills, for example. Also suitable for bridging in the area of the console brackets.

Cover Plates UDB 20 are available in lengths of 100 and 150 cm.



- At least Support area on both sides: 7.5 cm over the entire width
- Max. load class 3 according to EN 12811 ($p = 2.0 \text{ kN/m}^2$).
- Do not walk on the cover plates until they are screwed securely to the adjacent decks.

Components

166 Cover Plate UDB 20x100/150

167 Truss-head screw M10x60
DIN 603 -8.8

168 Nut M10-8-VZ-SW17

Assembly

1. Completely line the scaffold around the filler area with Decks UDG.
2. Place the cover plate (**166**) on the bridging area.
3. Insert the flat round screws M10x60 (**167**) through the existing holes or slots from above and tighten with nuts M10-8-VZ-SW17 (**168**).
 - Use at least 2 screws per support, therefore 4 per cover plate.
 - The screw connection can be made through any hole or slot. (Fig. A7.05a)
4. Mount further cover plates in the same way until the deck gap is closed. (Fig. A7.05b)

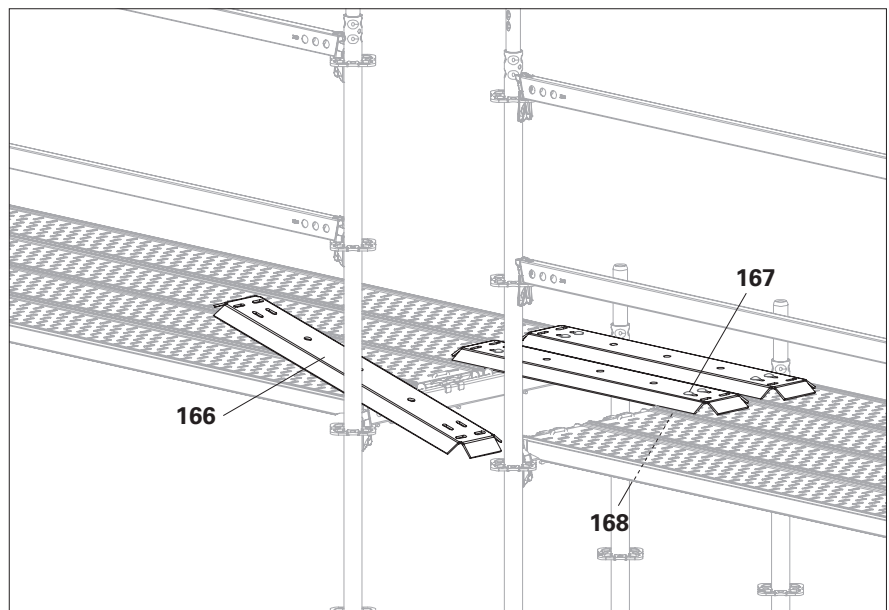

Fig. A7.05a

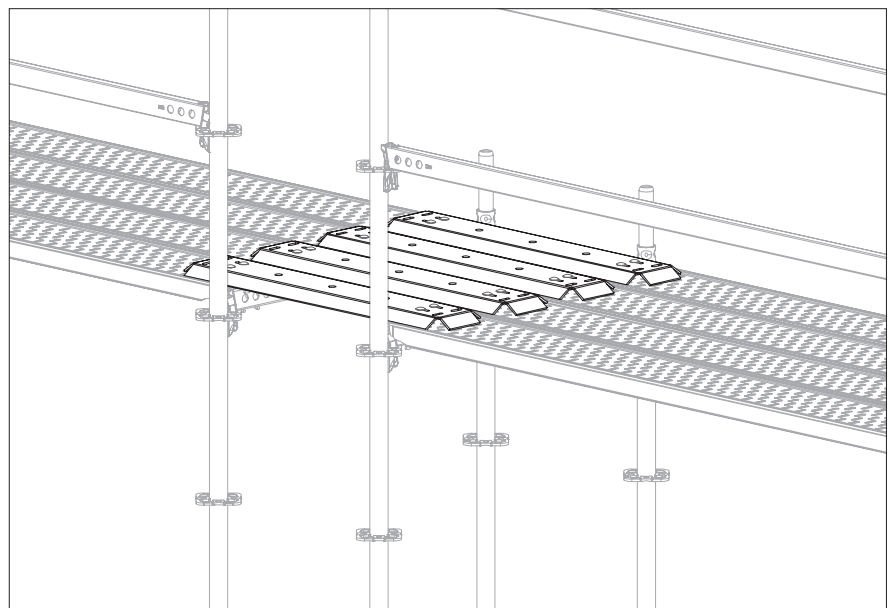

Fig. A7.05b

Inside Corner Plate EDP 25 /33

For closing the remaining inside corner when installing internal console brackets.

- Max. load class 4 according to EN 12811 ($p = 3.0 \text{ kN/m}^2$).

Assembly

- From a safe position on the scaffolding level immediately below:
 1. Fit console brackets or supports on the inner side of the scaffolding.
 2. Put on the decks.
 3. Place the Inside Corner Plate EDP (**51**) on the adjacent console bracket decks.
 4. Push the bolts of the Inside Corner Plate EDP (**51.1**) up. (Fig. A7.06a)
 5. Push the inside corner plate towards the vertical and slide the standard mounting cone over the rosette.
 6. Engage the bolt completely in the brace adapter of the rosette. (Fig. A7.06b)
- The deck is now fixed in position (Fig. A7.06 + A7.06c)



Is the bolt securely engaged in the rosette?

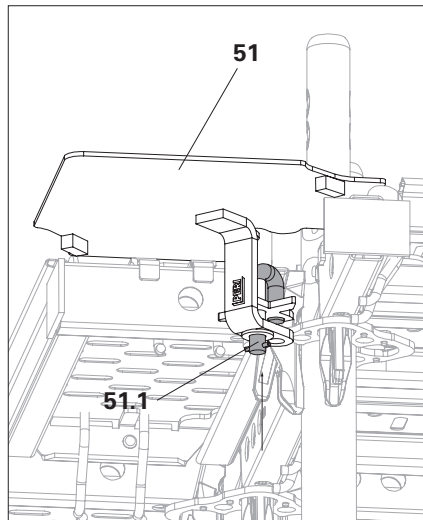

Fig. A7.06a

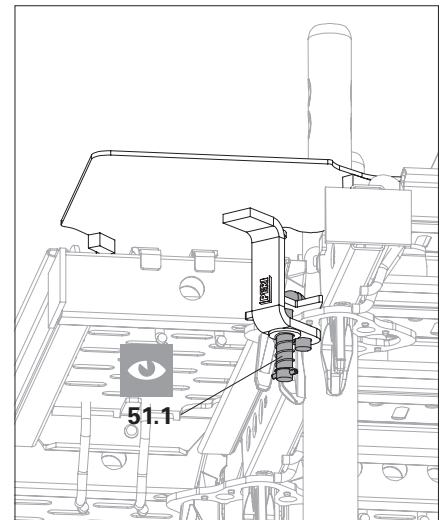

Fig. A7.06b

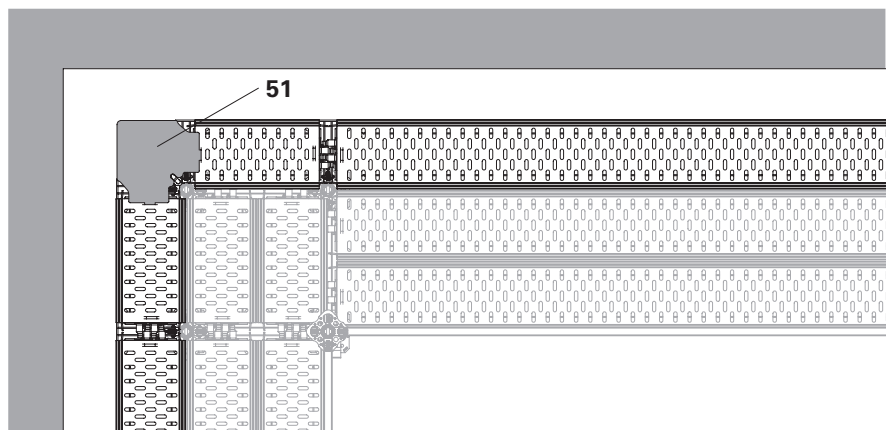

Fig. A7.06c

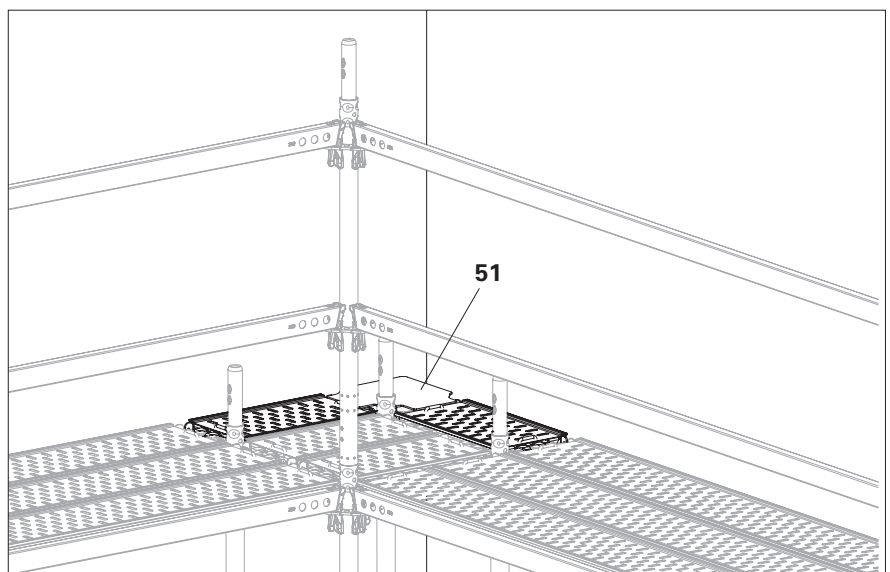

Fig. A7.06c

Cover Plate UDP

Cover Plates UDP (**52**) are available for scaffold widths 67 cm, 75 cm and 100 cm.



- Max. LC3 in the transition area.
- Create lateral protection in the transition area individually. Use PPE.

Assembly

- From a safe position on the scaffolding level immediately below:
1. Connect partial scaffolds at the greater distance with Horizontal Ledger UH Plus (**14**).
 2. Thread the Cover Plate UDP (**52**) through the gap and place it between the subframes on top of both deck sides.
 3. Pull the wedge (**52.1**) out of the clamping part (**52.2**) and lower the clamping part over the horizontal ledger (**14**).
 4. Insert the wedge into the clamping part and hammer it tight.
- Cover plate is installed.
(Fig. B7.05 – A7.07b)

Application examples

- Bridging of scaffolding parts that are not in alignment, e.g. due to the shape of the building.

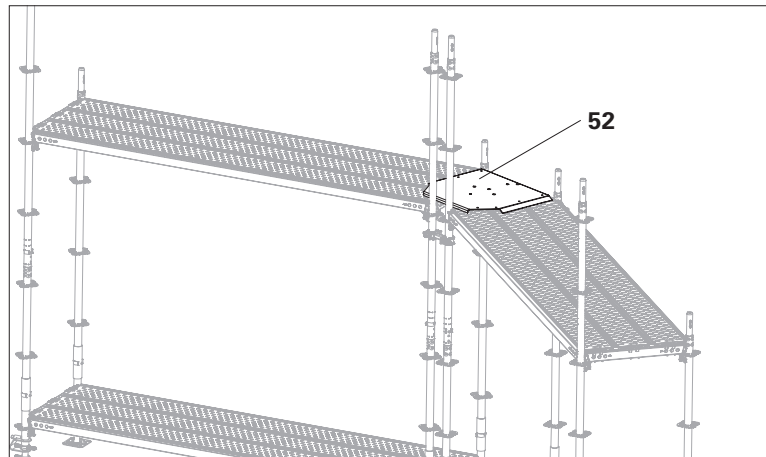

Fig. A7.07

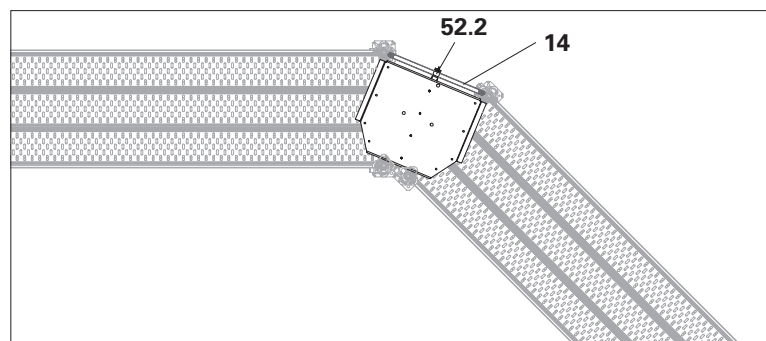

Fig. A7.07a

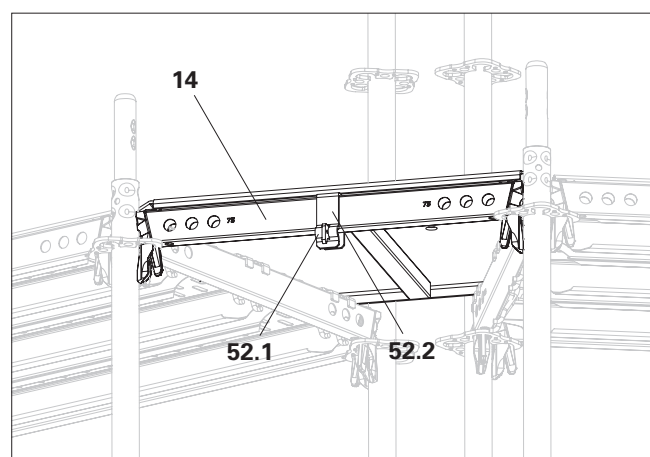

Fig. A7.07b

Corner Plate UDC

Corner Plates UDC (**53**) are available in leg sizes 50 cm, 75 cm and 100 cm.

Build up the corner plates layer-by-layer with the base scaffold.

- Max. load class 3 according to EN 12811 ($p = 2.0 \text{ kN/m}^2$).

Assembly

- From the scaffolding level below:
 1. Mount horizontal ledgers (**14**) next to the decks on the side facing the structure. Install transverse horizontal ledger (**14a**) with Ledger-to-Ledger Coupler UHA-2 (**93**).
 2. Pull out wedges (**53.1**) from both clamping parts (**53.2**) and lower clamping parts over both horizontal ledgers.
 3. Insert the wedges into the clamping part and hammer them in tight.
→ Corner plate is installed.
(Fig. A7.08 – A7.08b)

Application example

Building around of round components such as chimneys, columns, pipelines, etc.

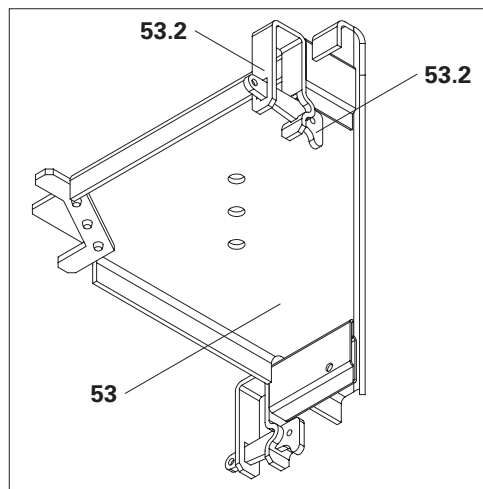

Fig. A7.08

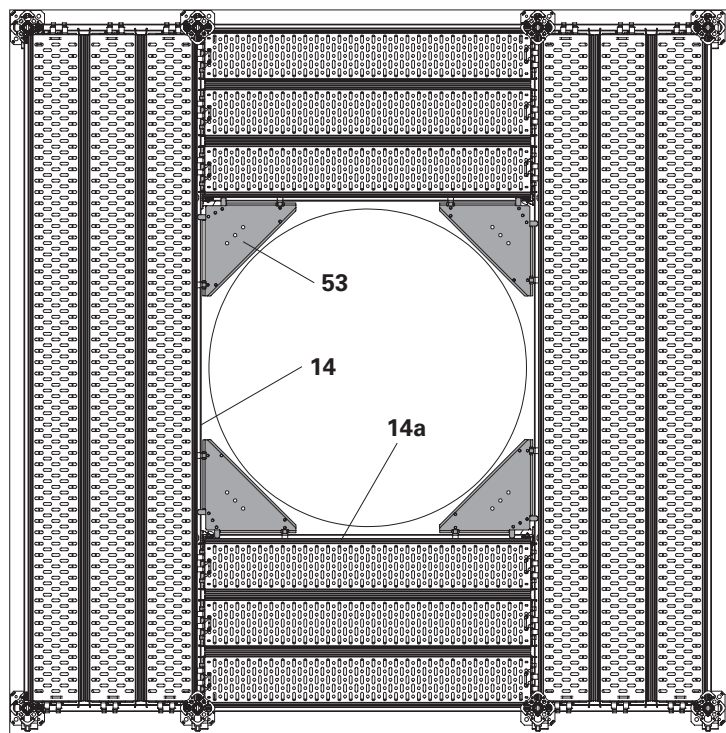

Fig. A7.08a

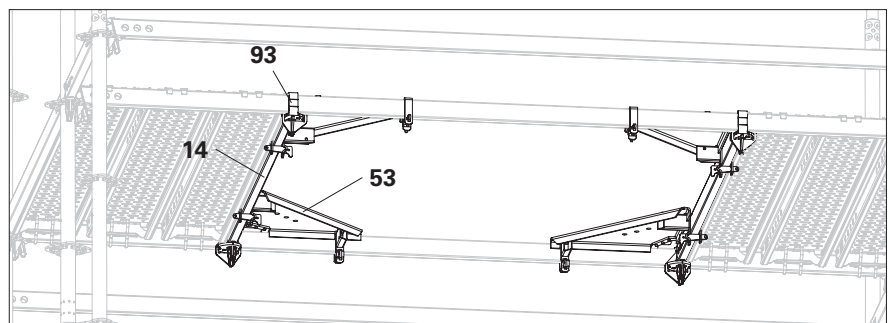

Fig. A7.08b

General



Warning

- Open access hatches pose a risk of falling.
- ⇒ Arrange the access openings alternately!
- There is a danger of falling from ladders.
- ⇒ Always ascend and descend facing the ladder.
- ⇒ Always grasp the ladder with at least one hand.
- ⇒ Never move or shift ladders while they are in use.
- ⇒ Never carry a load or an object when climbing up or down.
- ⇒ On mobile scaffolds, activate all wheel brakes before climbing.
- ⇒ Before installing, clean boots or shoes of foreign bodies or slippery substances.
- ⇒ Ladders should only be used by one person at a time.



Caution!

- Hatch can trap body parts if it closes on its own.
- ⇒ Guide the access hatch by hand when closing, do not let it fall shut!
 - ⇒ Take into consideration any other persons waiting to use the hatch!



Note

Do not overpress the hatch to more than approx. 95° as this may cause damage.



- For wider scaffolding bays, the remaining area next to the passage decks must be filled with steel decks to prevent sideways shifting
- All ascents with access decks or passage decks are possible up to max. load class 3 (LC3).
- The hatches must always be kept closed, except when climbing through!

Components

60a	Access Deck UAA 75 L
60b	Access Deck UAC 75 L
60c	Access Deck UAW 75 L
61a	Passage Deck UAA 75
61b	Passage Deck UAC 75
61c	Passage Deck UAW 75
62	Ladder UAF 200
63	Passage UAF 50x75
64	Passage UAF 75x100

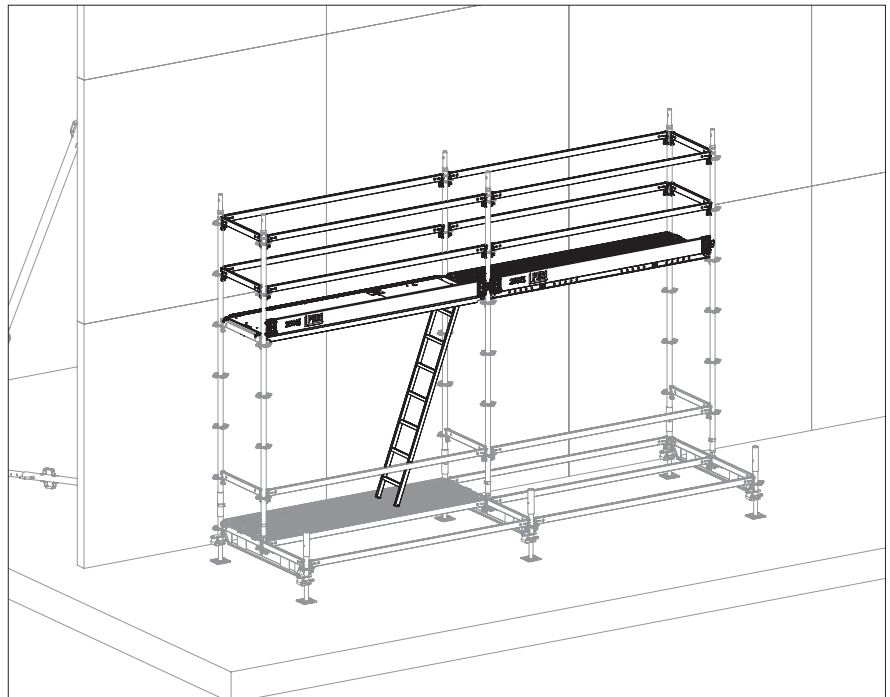

Access Decks UAA/UAC/UAW

Access decks (**60**) are available in lengths of 2.50 m and 3.00 m. The access ladder is permanently installed.

The following surfaces are available for decks:
 aluminium profiles (UAA),
 glass fibre reinforced plastic (UAC),
 coated plywood board (UAW).

Assembly

1. Install access deck (**60a**) in the same way as steel deck.
 2. Secure the ladder on the lowest rung and unlatch latch (**60.1**). (Fig. A8.02a)
 3. Set the ladder down on the scaffolding level underneath. Guide the ladder, do not allow it to drop.
- Access deck is installed.

Application examples

Scaffolds with few layers,
 Scaffolding bay lengths 2.50 m and 3.00 m,
 Reinforcement scaffolds.



Ladders must stand 2.0 m lower, e.g. on a layer below.
 Never use ladders in a suspended position.
 Observe national regulations.

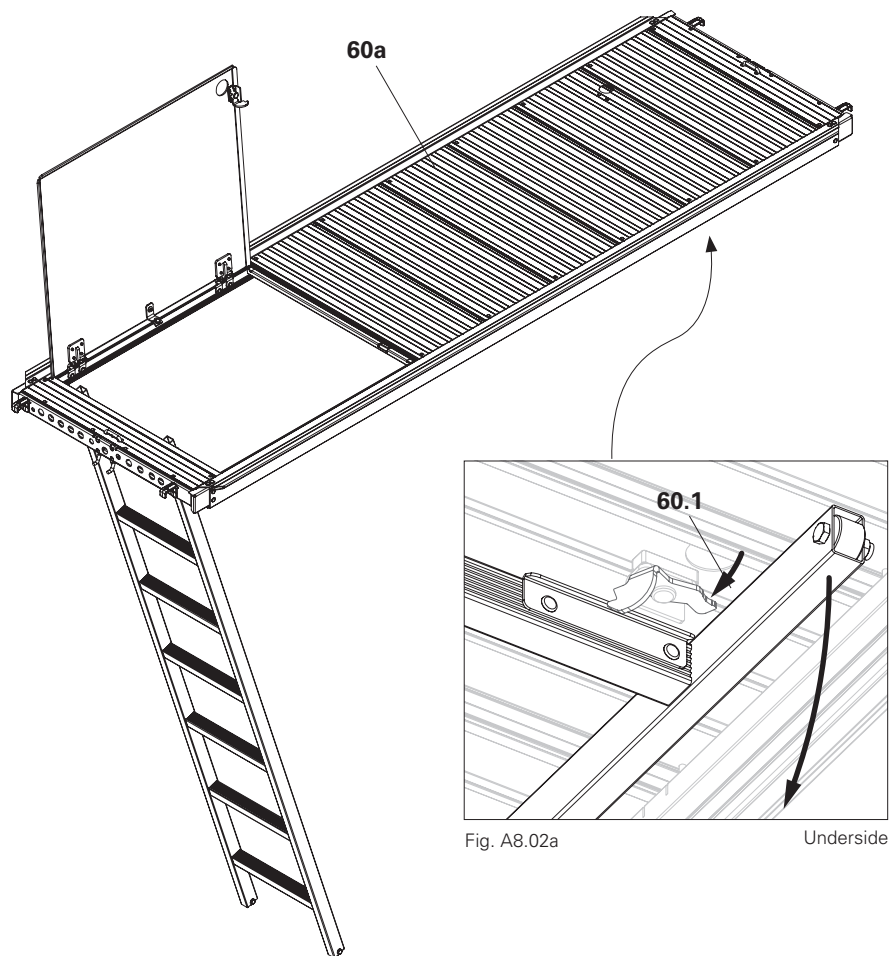

Fig. A8.02a

Underside

Fig. A8.02

Passage Deck UAA/UAC/UAW

Passage decks (**61**) are available in lengths of 1.50 m and 2.00 m. The Ladder UAF 200 (**62**) is also required as an access ladder.

The same materials as for passageway decks are available for deck surfaces.

Assembly

1. Install passage deck in the same way as steel deck.
2. Open access hatch and temporarily secure against falling.
3. Lift the ladder into the passage opening and hang it over the round tube (**61.1**) from above. (Fig. A8.03a)
4. Remove the temporary safety catch on the hatches and close the hatch.
→ The entry platform is installed.

Application examples

Scaffolds with few layers,
Scaffolding bay lengths 1.50 m and 2.00 m,
Reinforcement scaffolds.



Ladders must stand 2.0 m lower, e.g. on a layer below.
Never use ladders in a suspended position.
Observe national regulations.

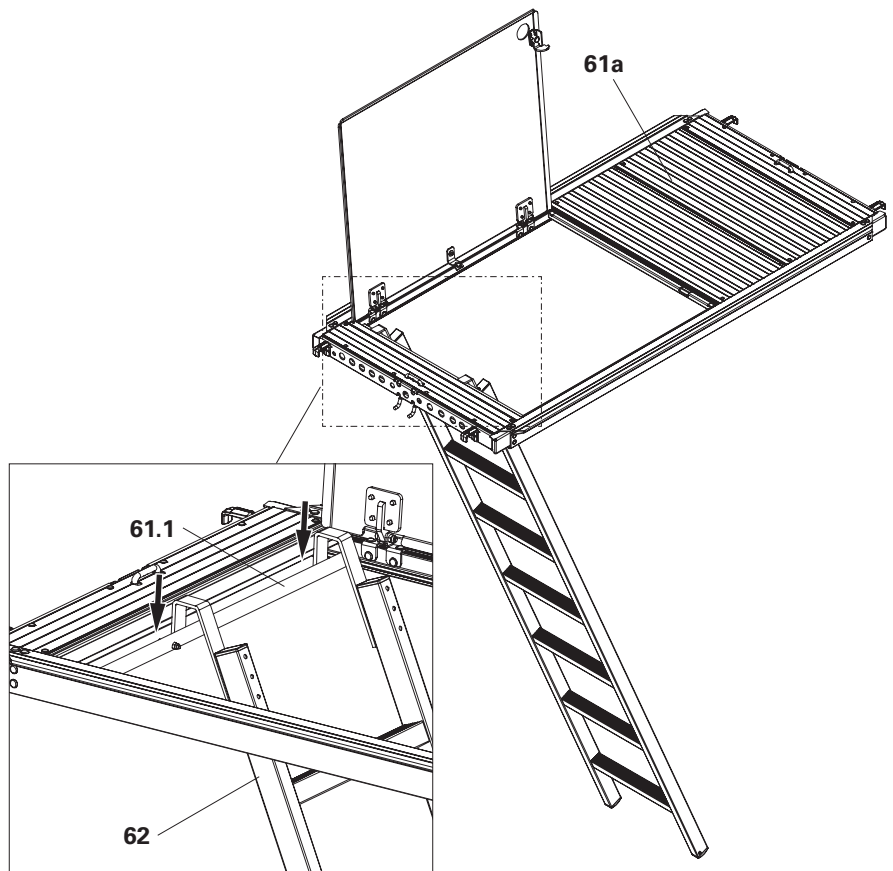

Fig. A8.03a

Fig. A8.03

Fig. A2.14b

Passage UAF

Passages (**63**) are available in the dimensions 75x50 cm and 75x100 cm. Passages can be freely positioned regardless of the bay length. Depending on the positioning and bay size, additional horizontal ledgers and decks may have to be installed. In addition, the Ladder UAF 200 is required as an access ladder.

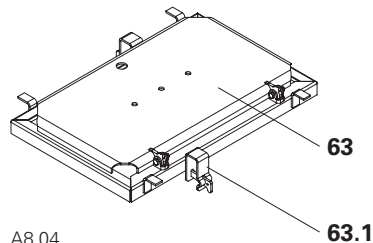

Fig. A8.04

Max. load class LC6 according to EN 12811, ($p = 6.0 \text{ kN/m}^2$).
 Frame made of galvanised steel, lid made of anti-slip aluminium chequer plate.

Assembly

1. If necessary, install additional horizontal ledgers (**14**) with Ledger-to-Ledger Coupler UHA (**93**) in the system dimension. Do not secure the wedges yet. (Fig. A8.04a + A8.04c)
2. Fill the remaining bay area with decks, correct the position of the horizontal ledgers if necessary.
3. Pull the wedges out of the clamping parts (**63.1**) of the Passage UAF and lower the clamping parts over the horizontal ledgers.
4. Push the wedges through the clamping part.
5. Hammer all wedges into place.
 → The Passage UAF is installed. (Fig. A8.04b + A8.04d)

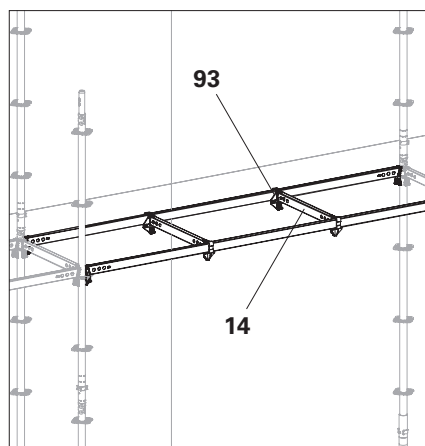

Fig. A8.04a

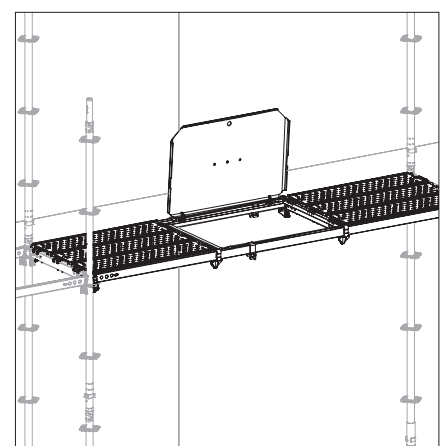

Fig. A8.04b

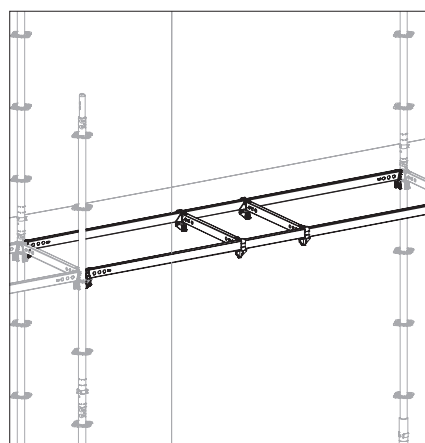

Fig. A8.04c

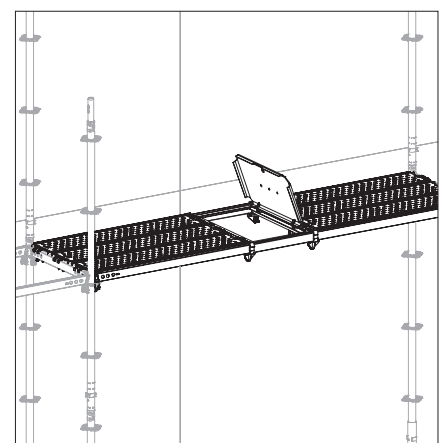

Fig. A8.04d

Application examples

Industrial scaffolds, platforms.

Stair towers

The Flex or Easy staircase makes it possible to build staircases that run in the same direction or in opposite directions.

Technical data

- Permissible load 2.0 kN/m²
- Flex Stair UAS-2 and Easy Staircase EAS fulfil class B according to DIN EN 12811-1.

Available sizes WxLxH:

Components

-
- 79a** Flex Stair UAS-2 75x300/200
 - 79b** Flex Stair UAS-2 75x250/200
 - 79c** Flex Stair UAS-2 75x150/100 T with landing platform at top
 - 79d** Flex Stair UAS-2 75x150/100 S with landing platform at bottom
 - 79e** Flex Stair UAS-2 75x150/50 S with landing platform at bottom
 - 79f** Flex Stair UAS-2 75x150/50 T with landing platform at top
 - 79g** Flex Stair UAS-2 75x75/50
-
- 79a*** Easy Stair EAS 67x300/200
 - 79b*** Easy Stair EAS 67x250/200
 - 79c*** Easy Stair EAS 67x150/100 T with landing platform at top
 - 79g*** Easy Stair EAS 67x75/50
-

*Image similar

Only the Flex Stair UAS is described in these Instructions for Assembly and Use. The Easy stair is used in the same way.

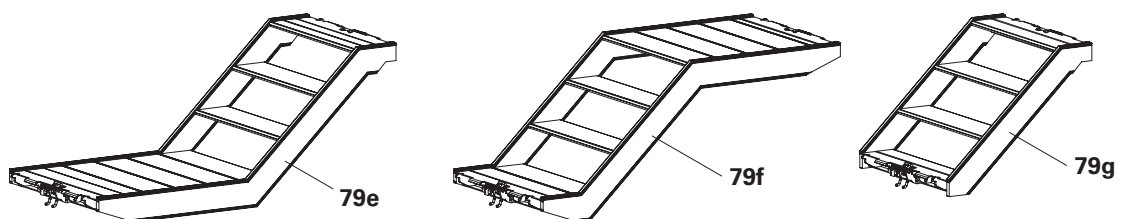
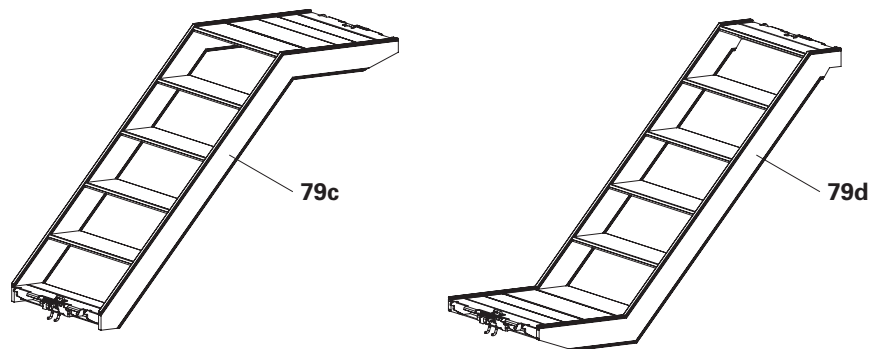
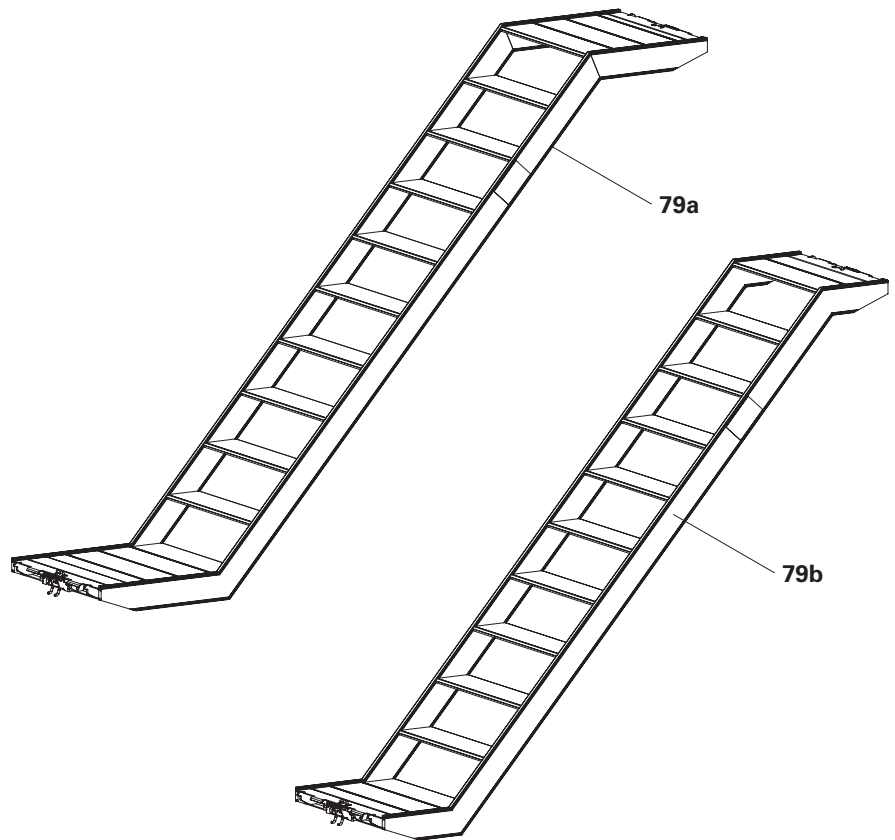

Assembly

As with access decks or passage decks, the installation is carried out on Horizontal Ledgers UH.

1. Mount the Stair Tower UAS (79) first on the upper Horizontal Ledger (14a), then on the lower Horizontal Ledger (14b). Both lift locks (79.1) must fall under the horizontal ledgers. If not, lift the staircase slightly and let it drop into position or operate the lift lock manually. (Fig. A8.05b)
2. Produce lateral protection on stairs and platform opening according to the project.

See also the following section and system-specific Instructions for Assembly and Use, e.g. PERI UP Flex Stair 75.



For wider scaffolding bays, the installation width must be limited to the dimensions of the intended staircase. For the alternating staircase unit, limit the installation width to 150 cm to prevent lateral shifting. The ledger-to-ledger coupler UHA Half (94), for example, is suitable for this limitation. (Fig. A8.05b)

Application examples

Access to platforms, stairways, stair towers.

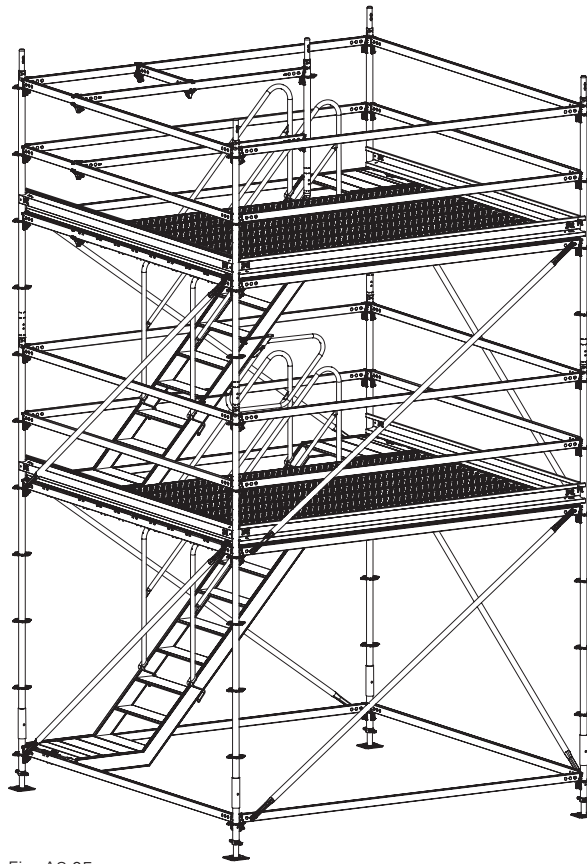

Fig. A8.05

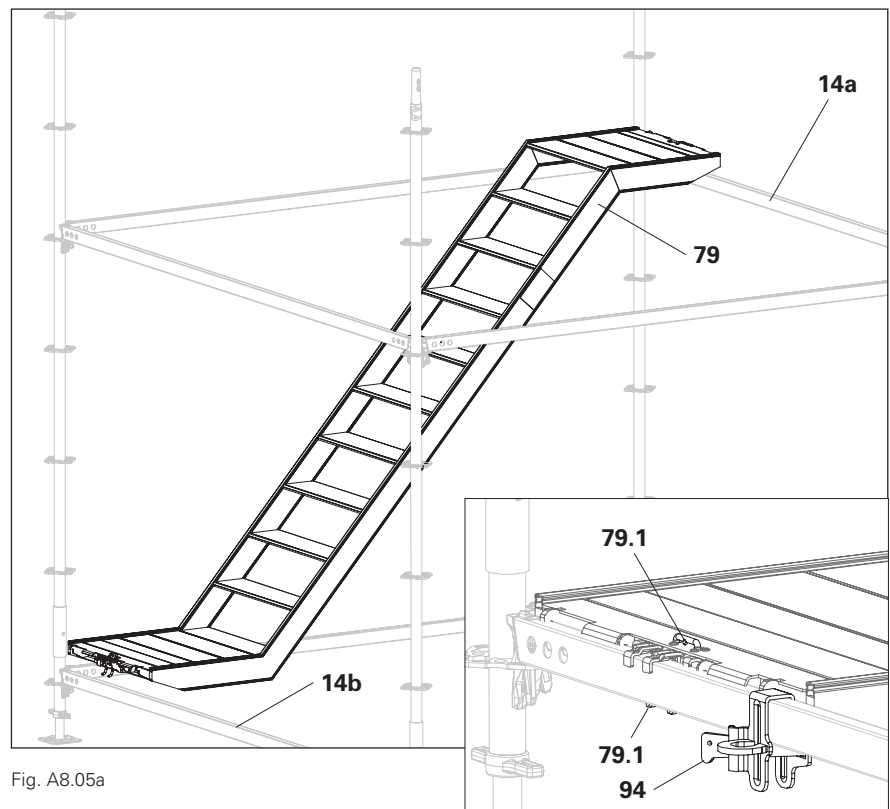

Fig. A8.05a

Fig. A8.05b

Stair Guardrail UAG

Assembly

Fit Stair Guardrail UAG (**160**) with upper suspension (**160.1**) above the second step (**79.1**) from the top.

1. Attach the Stair Guardrail UAG to the stair rail using the mounting rings (**160.1**). (Fig. A8.06a)
 2. Lower the stair guardrail to the step and pull the mounting rings to the rear edges of the steps (**79.2**). (Fig. A8.06b)
- Stair guardrail is installed.

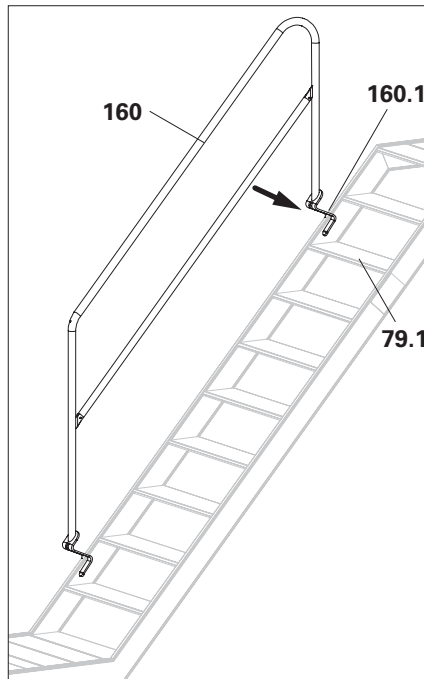

Fig. A8.06a

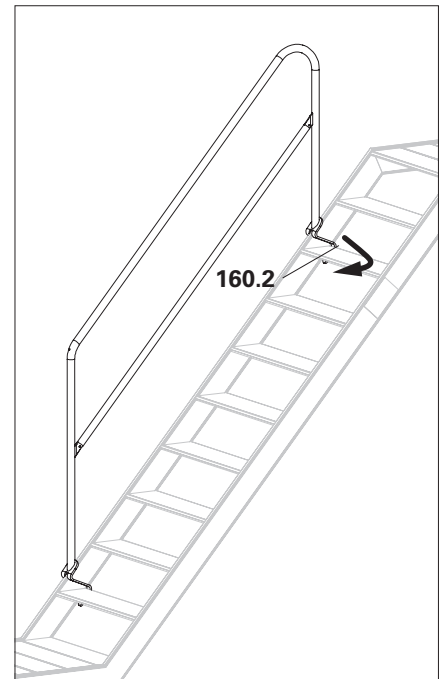

Fig. A8.06b

Stair Guardrail UAH-2

Assembly

Fit Stair Guardrail UAH-2 (**161**) onto the fifth step (**79.2**) from the top with the upper mounting ring (**161.1**).

1. Attach the stair guardrail from the back of the staircase to the stair rail using the mounting rings (**161**). (Fig. A8.07a)
 2. Lower the stair guardrail to the step and pull the mounting rings all the way to the front edge of the step (**79.4**). (Fig. A8.07b)
 3. Swing out the locking pin (**161.2**) and pull it down between the stair tower and the stair guardrail. (Fig. A8.07c + A8.07d)
- Stair guardrail is installed and secured.
- The upper guardrail post is at a height of approx. 1 m.

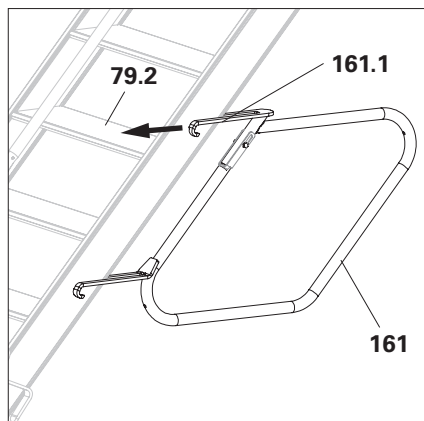

Fig. A8.07a

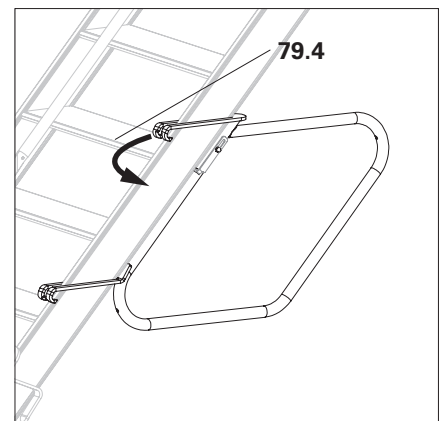

Fig. A8.07b

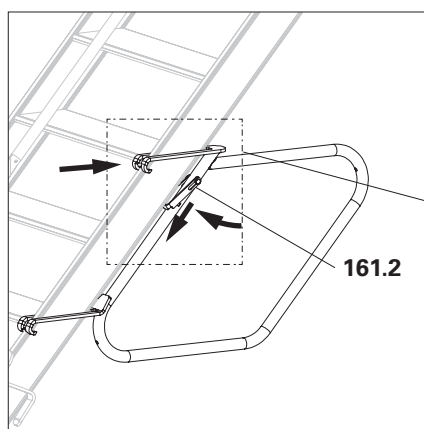

Fig. A8.07c

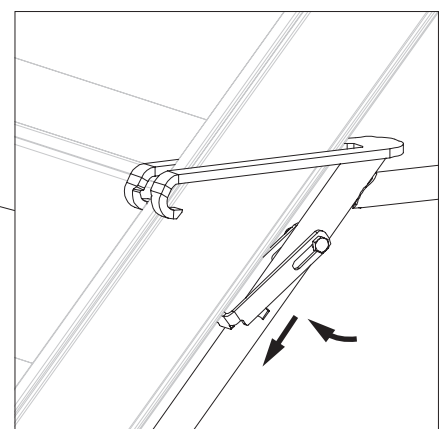

Fig. A8.07d

General



Warning

There is a danger of falling from ladders.

A fall can cause serious or fatal injuries!

- ⇒ Always ascend and descend facing the ladder.
- ⇒ Always grasp the ladder with at least one hand.
- ⇒ Never use the upper edge of the ladder as a step.
- ⇒ Never move or shift ladders while they are in use.
- ⇒ Never carry a load or an object when climbing up or down.
- ⇒ On mobile scaffolds, activate all wheel brakes before climbing.
- ⇒ Clean boots or shoes of foreign objects or slippery substances before ascending.
- ⇒ Ladders should only be used by one person at a time.

Components

- | | |
|------------|-------------------------------------|
| 69 | Ladder Connector UAC-2 |
| 70 | Ladder Connector UAV 43-C |
| 71 | Ladder Connector Ledger UAM-S |
| 72 | Ladder Connector Ledger UAM-W |
| 73 | Ladder Connector Diagonal UAD |
| 74 | Vertical Ladder UAV 43x91 |
| 74a | Vertical Ladder UAV 43x181 |
| 75 | Aluminium Ladder UAI 300/400/500 -A |
| 76 | Ladder 180/6 |
| 77 | Ladder base |
| 78 | Ladder Safety Cage 75/150 |

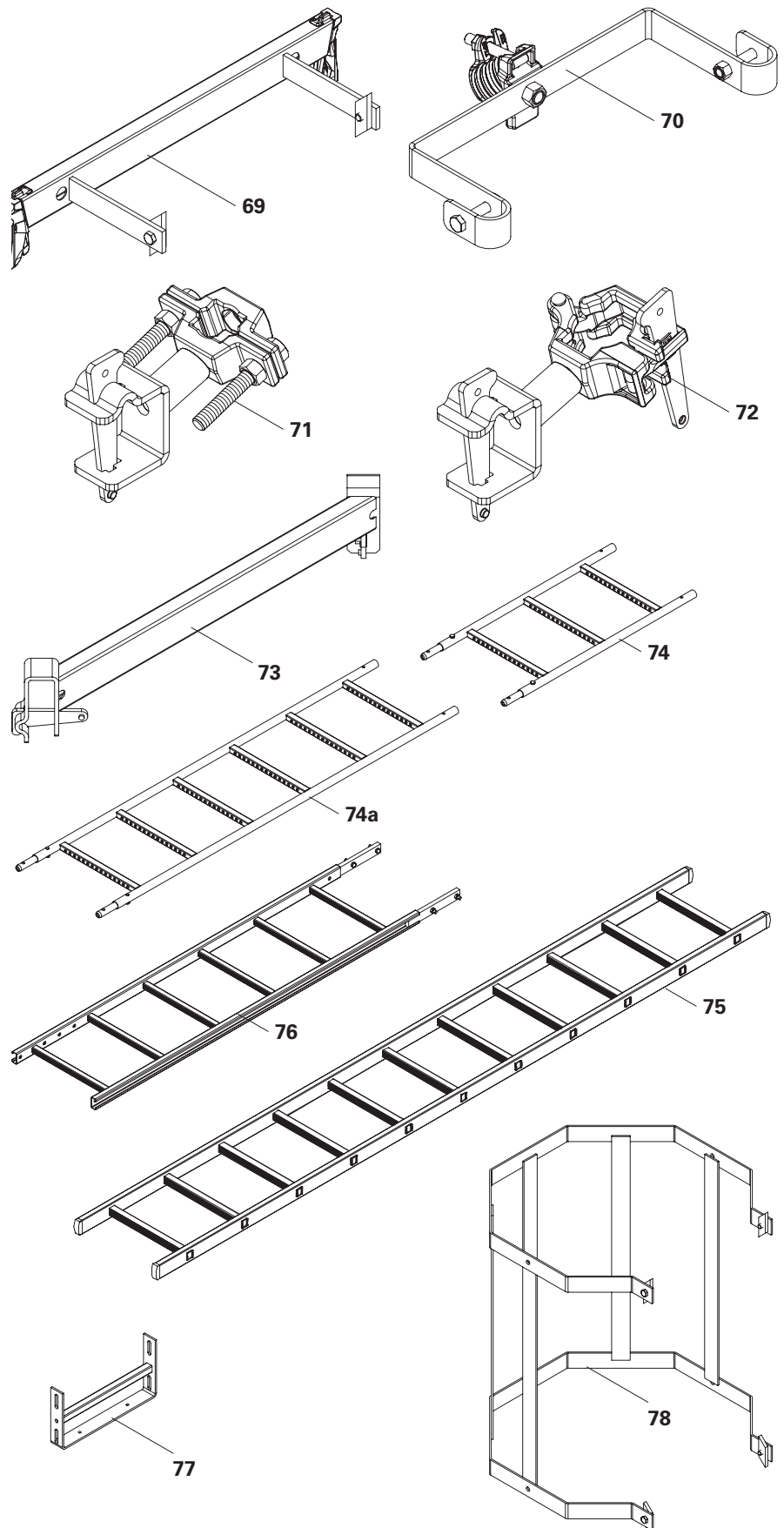



Install rest areas every 10 m for ladder access.

- Tighten the tube couplings with 50 Nm
- Ladder connections do not absorb vertical forces, therefore place the lowest element of the ladder load-bearing on the substrate.
- Each time you start work, check the ladders and brackets for damage and proper attachment. Do not climb damaged or improperly fixed ladders, but replace damaged components or fix ladders properly.
- Inclined and vertical ladders provide access to platforms. These can be employed externally or integrated into the platform.
- The ladder may be extended to a maximum height of 10.5 m.
- Access to the platform is via a safety entry door.
- The ladders are firmly connected to the scaffold using the Ladder Connector Ledger UAM-S and UAM-W, which means that the widening described in DIN 131 is not necessary.
- Observe country-specific regulations!
- Pinned ladders are only approved for vertical installation!
Only use undivided ladders for diagonal installation.

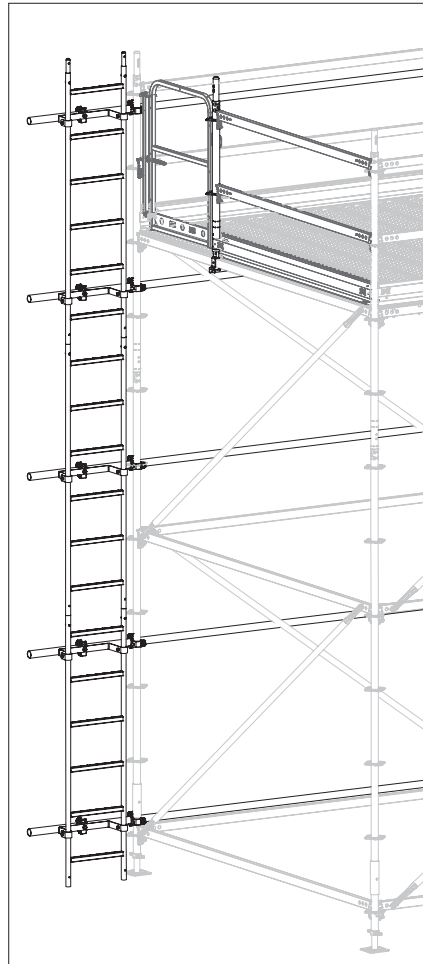

Fig. A9.01

Ladder Connector UAM-W

Suitable for

- Round tubes Ø 48.3 mm.
- Rectangular profile 60x30 mm.

Assembly of the ladder connector

1. Pull the wedge (**72.1**) out of the clamping part (**72.2**) and push the clamping part over the horizontal ledger (**14**).
2. Insert the wedge into the clamping part and hammer it tight. (A9.02a)
→ Ladder connector is installed.

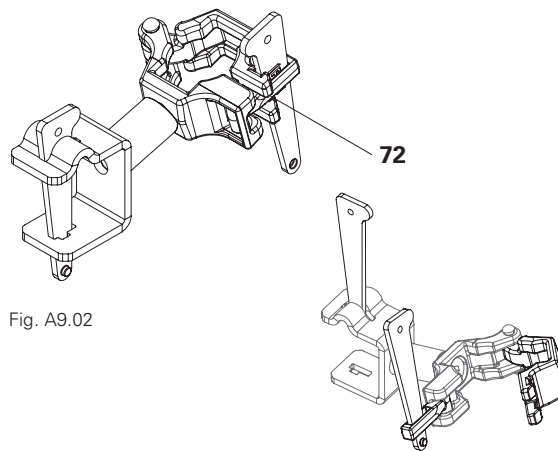

Ladder assembly

1. Knock out wedge from the half-coupling (**72.3**) and open half-coupling.
2. Insert the ladder and close the half-coupling. Secure the wedge. (Fig. A9.02b)
→ Ladder is installed.

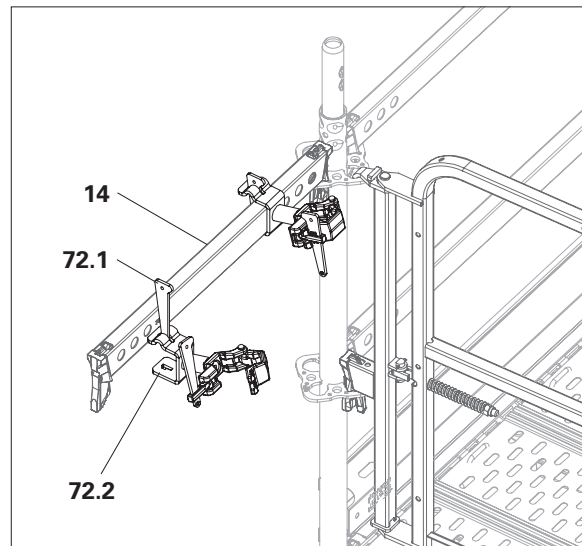

Fig. A9.02a

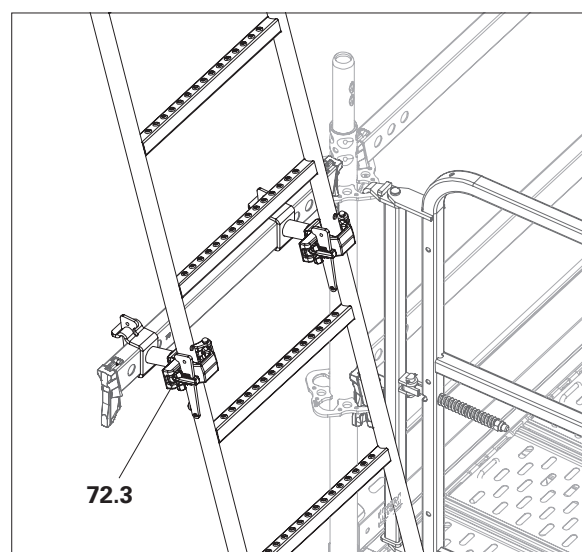

Fig. A9.02b

Ladder Connector Ledger UAM-S

Suitable for

- Round tubes from Ø 32.0 to 48.3 mm.
- Rectangular tubes with width 25 to 30 mm and height from 30 to 80 mm adjustable via screws.

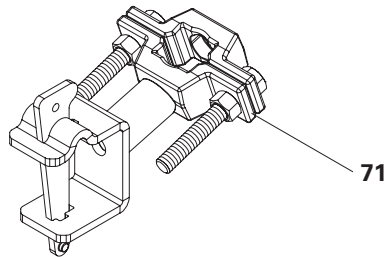

Fig. A9.03

Assembly of the Ladder Connector

The Ladder Connector Ledger UAM-W (71) is installed on the horizontal ledger in the same way as described for Ladder Connector Ledger UAM-S.

→ Ladder Connector UAM-S is installed.

Ladder assembly

1. Completely unscrew one screw (71.1) from the pipe clamp part (71.2). Open the second screw far enough that the ladder stile can be placed.
 2. Insert the stile into the pipe clamp.
 3. Swivel up the pipe clamp part and tighten with screws.
(Fig. A9.03 + A9.03a)
- Ladder is installed.

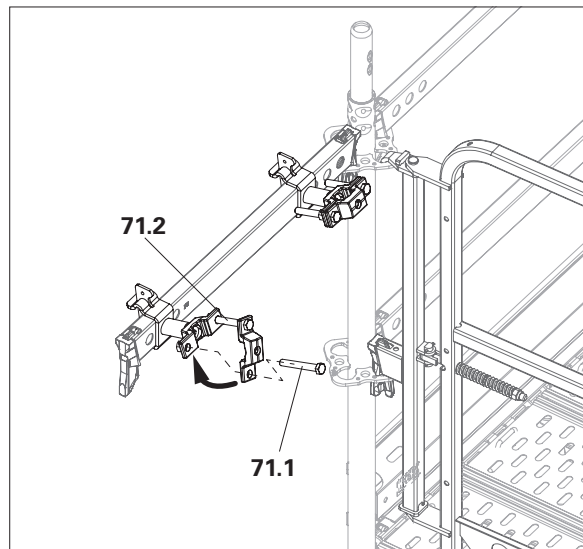

Fig. A9.03a

Ladder UAV

Ladder elements that can be plugged into each other, with holes for connection.

Dimensions: 43x91 cm
43x181 cm

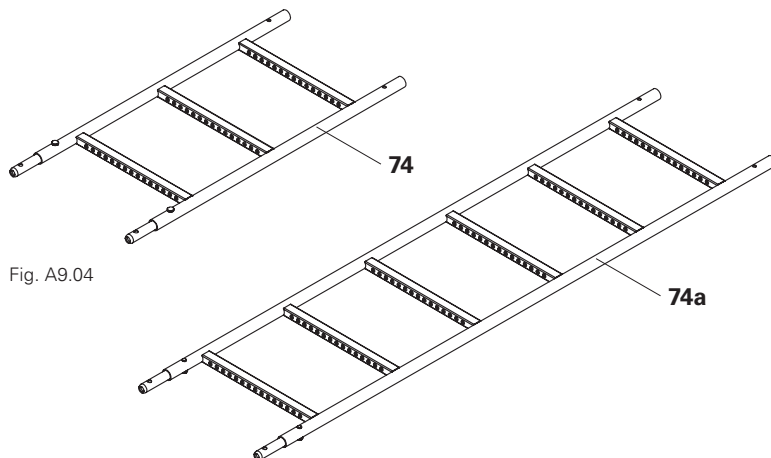

Fig. A9.04

Assembly

1. Assemble the individual elements of the Vertical Ladder UAV (74/74a) as required.
2. Secure pin connection with M10x40 bolt and nut. (Fig. A9.04)

Ladder Connector Diagonal UAD

When attaching a ladder to the side of the base scaffold, the Ladder Connector UAC-2 must be braced with the Ladder Connector Diagonal UAD (**73**). (Fig. A9.05a)

For assembly, see Section "Lower/ additional ladder connectors" on page 101.

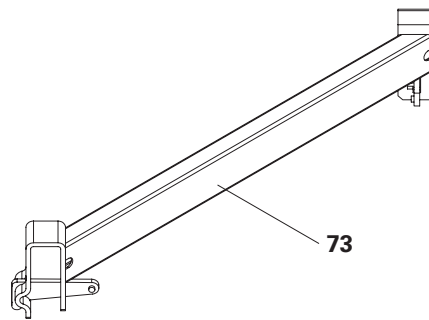

Fig. A9.05

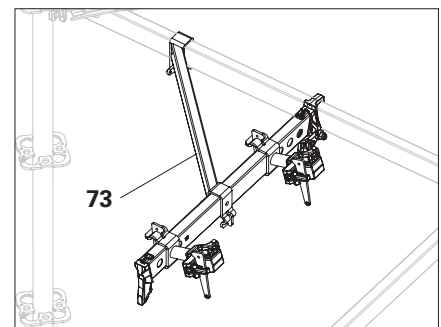

Fig. A9.05a

Installing the access ladder

Upper ladder connection

Assembly

1. Insert horizontal ledger (**14**) 1 m above the deck level on torsionally stiff standard (**12**) in the rosette and hammer wedge tight.
 2. Install Ladder Connector Ledger UAM-S or UAM-W (**72**) on horizontal ledger (**14**).
 3. Open the ladder connectors and place, for example, Ladder Alu UAI (**75**) in the half-shells of the ladder connectors.
 4. Adjust the ladder connectors to the stile spacing of the ladder and hammer the wedges in tight.
 5. Close the ladder connectors and tighten the screws or hammer the wedges in tight. (Fig. A9.06a + A9.06b)
- If other ladders are used, also follow the manufacturer's instructions for use.

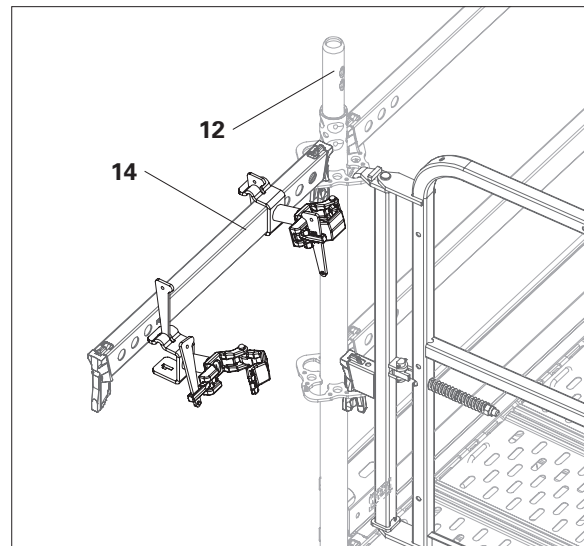

Fig. A9.06a

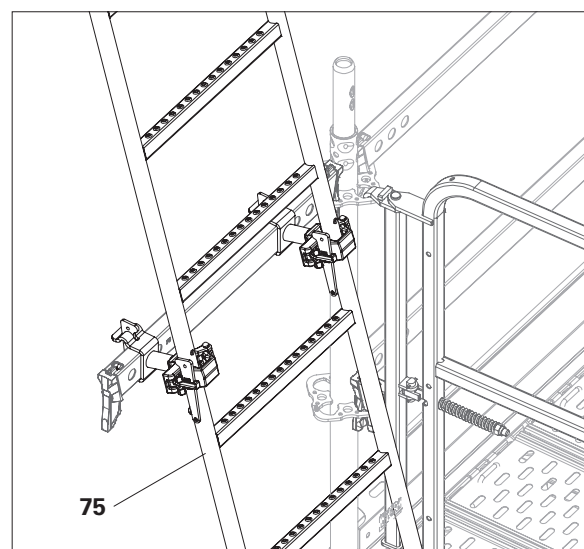

Fig. A9.06b

Lower/additional ladder connectors

The ladder must be held in position below with the ladder connector. Depending on the length, additional connectors may be necessary.

Assembly

1. Attach the Ledger-to-Ledger Coupler UHA-2 (93) and the horizontal ledger (14).
 2. Install Ladder Connector Ledger UAM-W (72) or UAM-S on horizontal ledger.
 3. Fit the Ladder Connector Diagonal UAD (73) to both horizontal ledgers for bracing and hammer the wedges in tight.
 4. Open the screws or wedges of the ladder connectors and place the ladder in the half-shells of the ladder connectors.
 5. Close the ladder connectors and tighten the screws or hammer the wedges in tight. (Fig. A9.07)
- Ladder is installed. (Fig. A9.07a)

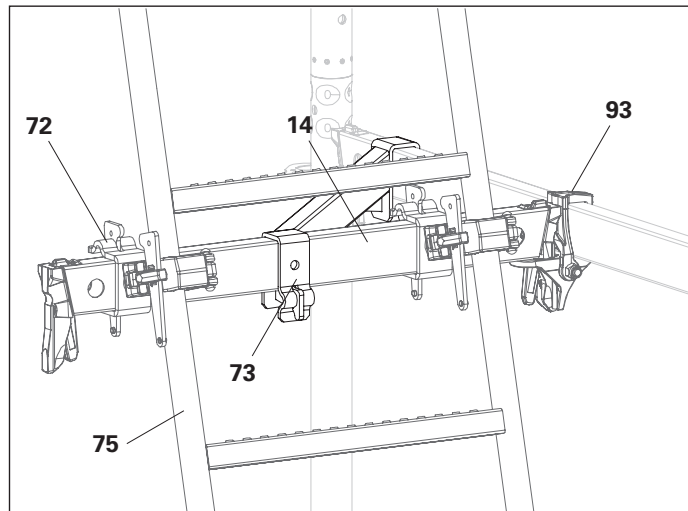

Fig. A9.07

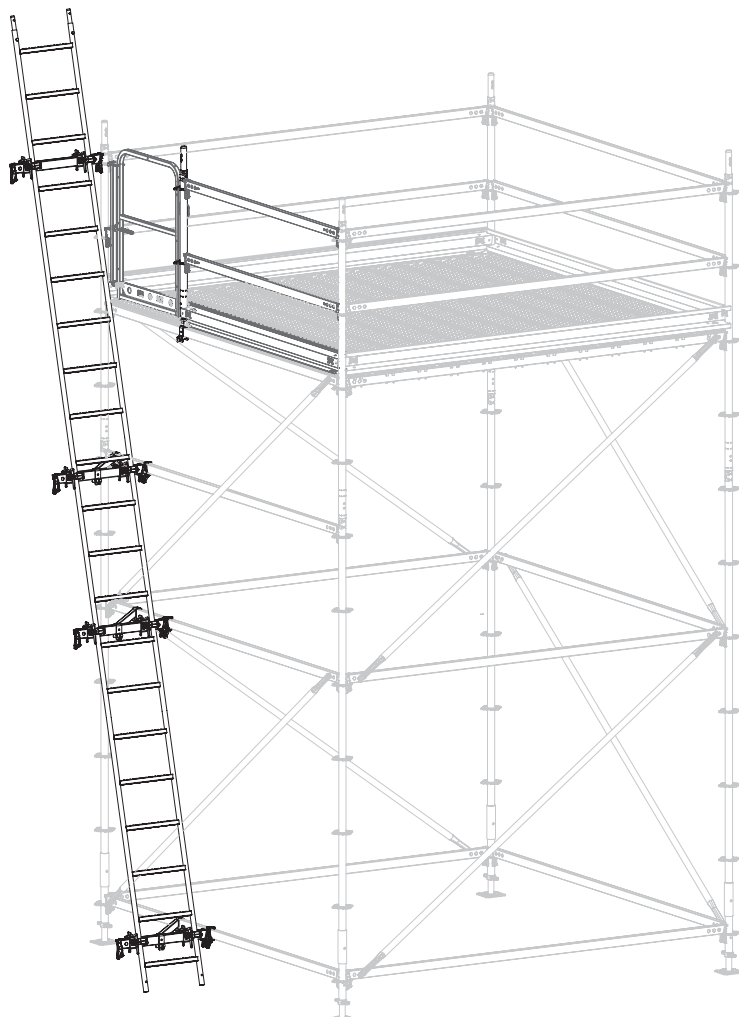

Fig. A9.07a

Ladder Connector UAV 43-C

For the lateral attachment of a Vertical Ladder UAV to the base scaffold with scaffolding tubes

Assembly

1. Pre-assemble the Vertical Ladder UAV (**74/75**) with the Ladder Connector UAV (**70**). (Fig. A9.08a)
2. For the first ladder element, mount the lower ladder connector between the first and second rung, and the upper ladder connector between the 7th and 8th rung. Install the rung.
3. Screw the side screw (**70.1**) through the nut on the inside of the ladder connector. At least one full thread turn must protrude. It is not necessary for the screw head to be flush.
4. Screw the scaffolding tube (**145**) to at least 2 standards (**12**) with standard couplers (**87**). (Fig. A9.08c) Distance between standards must be equal to the cantilever at least. (Fig. A9.08b)
5. Screw the ladder connector to the projecting scaffolding tube with the tube coupling (**70.2**). (Fig. A9.08b)
6. Ladder connectors do not absorb vertical forces, therefore place the first element of the Ladder Connector UAV load-bearing on the substrate.

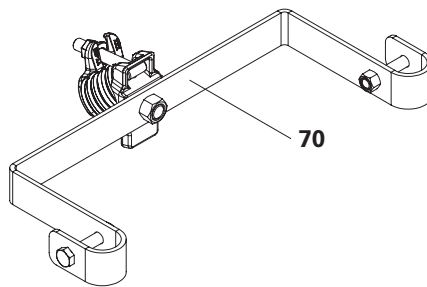

Fig. A9.08

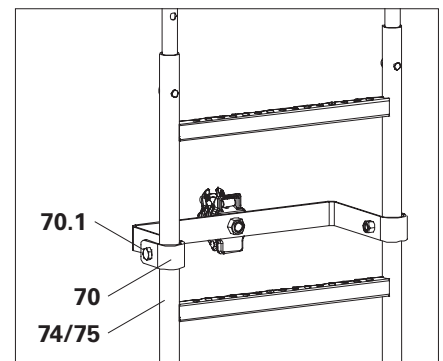

Fig. A9.08a

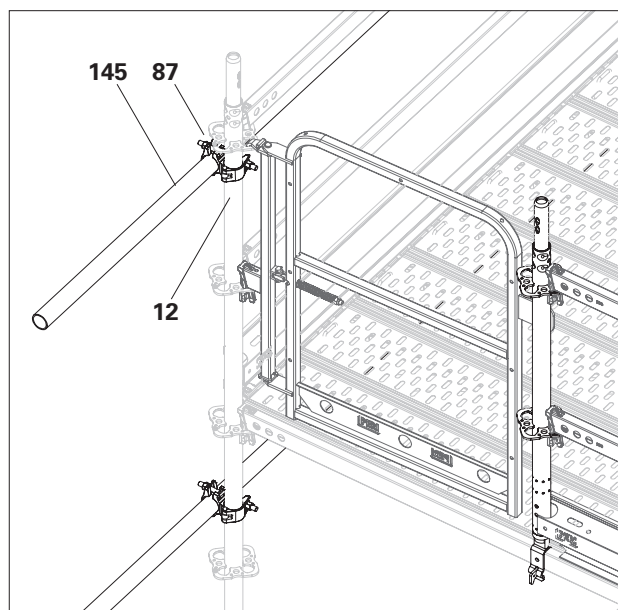

Fig. A9.08b

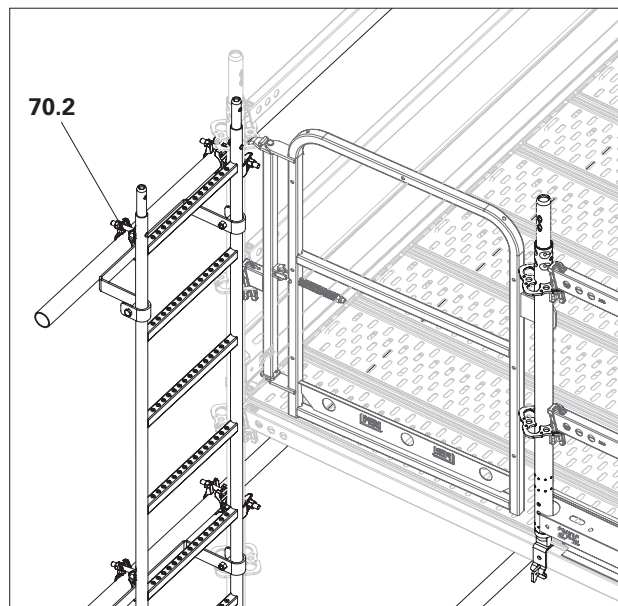

Fig. A9.08c

7. Fit each additional connected ladder with ladder connectors. Distance between ladder connectors approx. 1 m.
 8. Install the ladder access approx. 1 m above the desired access height.
 9. Fit a ladder connector at the top end of the ladder access in the area of the last rung.
- Ladder is installed. (Fig. A9.08d)

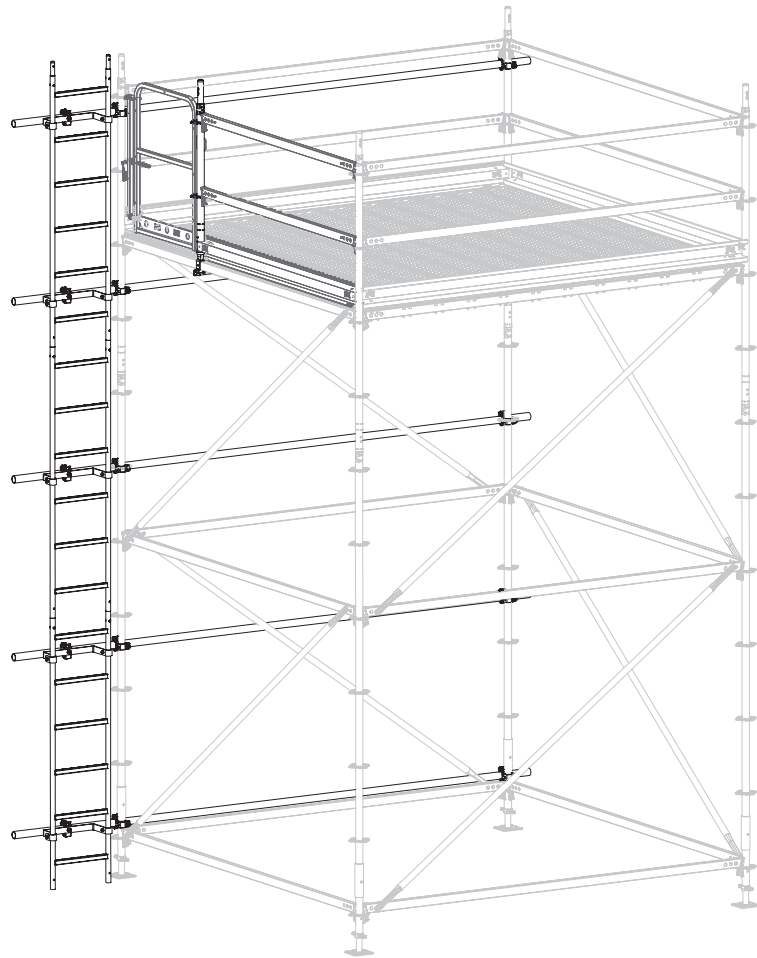

Fig. A9.08d

Ladder Connector UAC-2

For attaching ladders 180/6 to the base scaffold.

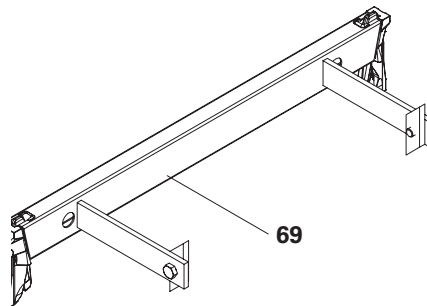

Fig. A9.10

Ladder 180/6

Connect ladder parts

1. Push the upper ladder 180/6 (**76**) with the connector piece (**76.1**) into the lower ladder 180/6 (**76a**) up to the stop.
2. Secure the bottom ladder to the connector using the 4x bolts M12 x 40 and nuts (**76.2**) which have been provided.
3. Install the ladder base (**77**) in the same manner with 4 bolts M12 x 40 and nuts onto the connecting piece of the lower ladder.

(Fig. A9.11)

Fixing the ladder base

1. Extend the bracket (**77.1**) of the ladder base to the substrate. Screw the bracket to the substrate using suitable means.

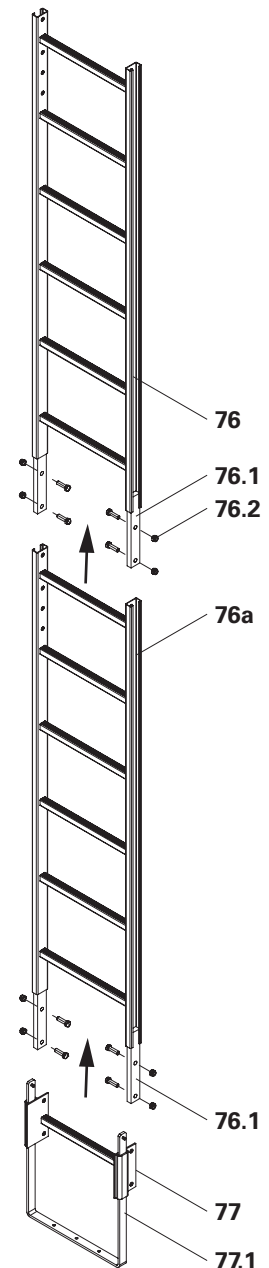

Fig. A9.11

Assembly

1. Insert two ladder connectors UAC- 2 (**69**) into rosettes on torsionally stiff standards (**12**) and knock wedges into place. (Fig. A9.12a)
 2. If necessary, brace Ladder Connectors UAC-2 with Ladder Connector Diagonal UAD.
 3. Fit ladder 180/6 to ladder connector. To do this, slightly loosen screw M12 x 25 of the clamping plate (**69.1**), insert the clamping plate into the ladder stile (**76.1**), turn and tighten the screw. (Fig. A9.12c + A9.12d)
 4. Ladder connectors do not absorb vertical forces, therefore screw the first element of the fixed ladder, e.g. with adjustable ladder base 30, to the substrate.
 5. Install each additional connected ladder with two ladder connectors. Distance between ladder connectors approx. 1 m.
 6. Install the ladder access approx. 1 m above the desired access height.
 7. Fit a ladder connector at the top end of the ladder access in the area of the last rung. (Fig. A9.12b)
- Ladder is installed.

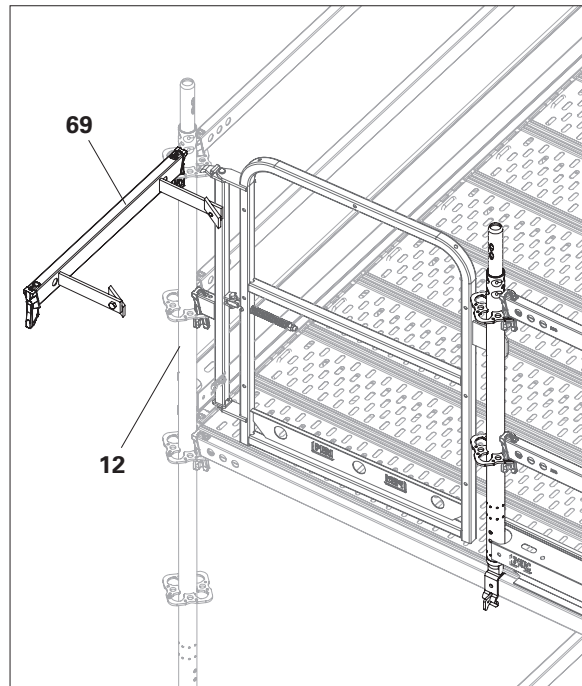

Fig. A9.12a

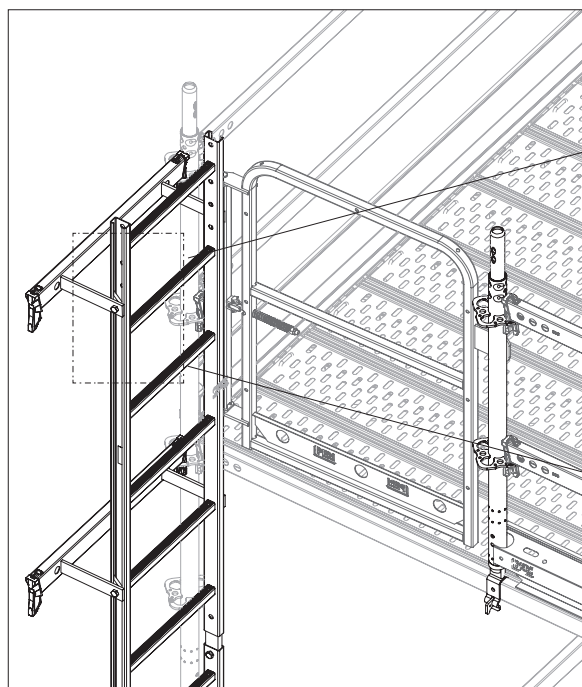

Fig. A9.12b

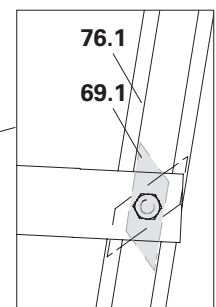

Fig. A9.12c

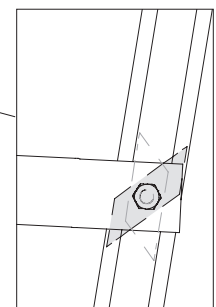

Fig. A9.12d

Mounting the ladder cage



- The distance from the erection surface of the ladder to the ladder cage may be a height of 2.2 m – 3.0 m.
- The opening between two ladder cages must not exceed 50 cm.
- If the ladder is installed parallel to the base scaffold, access to the scaffold is only possible in one position.

1. Bring and hold the ladder safety cage (78) in position using a rope.
 2. Slightly loosen screw M12 x 25 (4x) of the clamping plate (78.1), insert clamping plate into the ladder stile (76), turn and tighten screw.
- Ladder cage is installed (Fig. A9.13a + A9.13b)

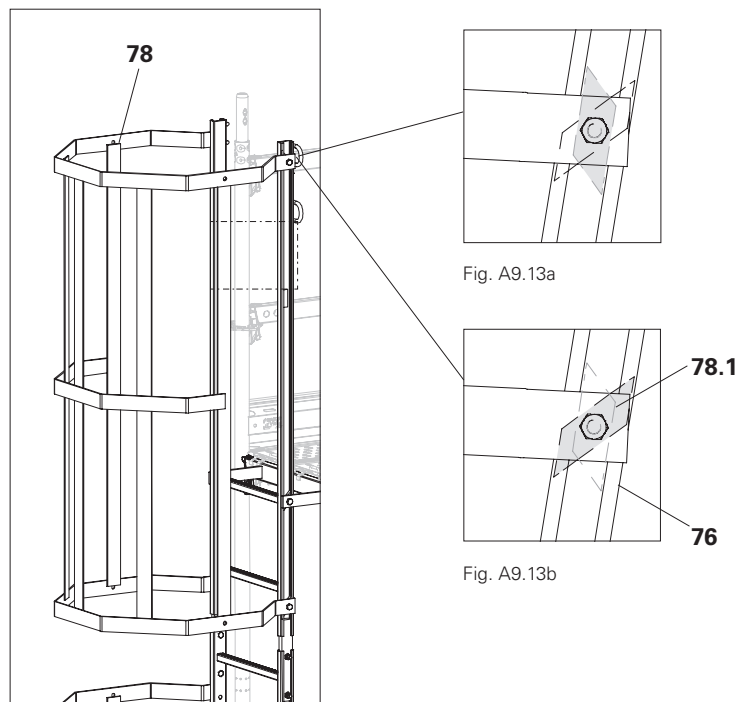

Fig. A9.13

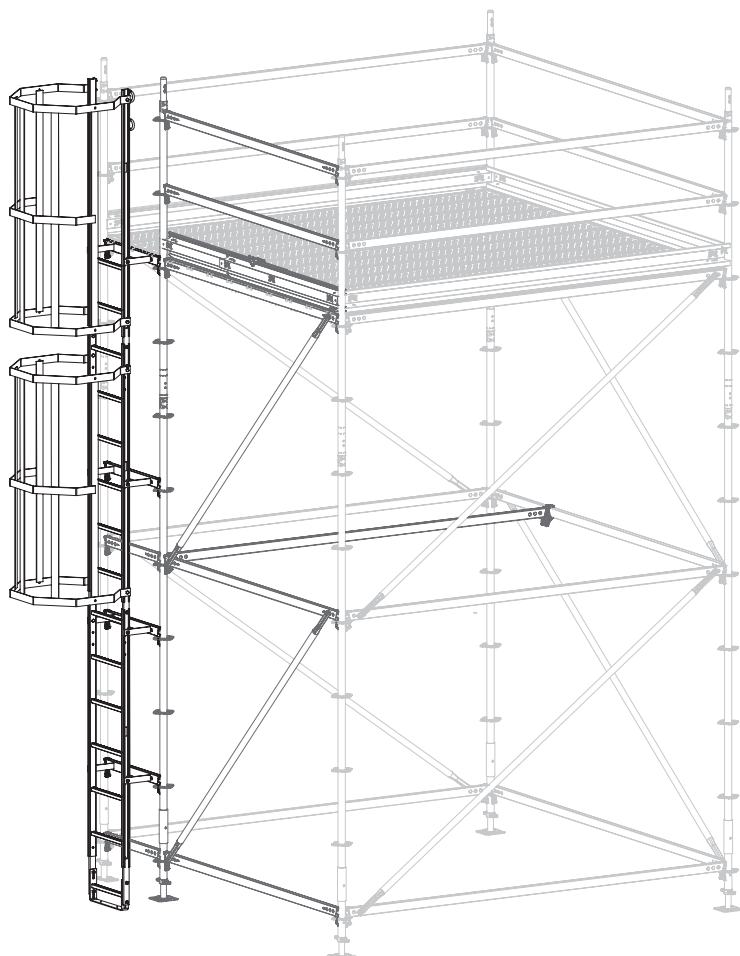

Fig. A9.14

General

Tighten all screw connections and couplings with 50 Nm.

In any case, carry out a structural stability analysis.

Components

- 80** Clamping Rosette UEV 180°
- 80a** Clamping Rosette UEV 90°
- 81** Coupling connection for UH 30/60
- 82** Coupling for UH
- 83** Spacer UEC-2
- 84** Tension coupler 1 1/2 inch
- 85** Tube connector 1 1/2 inch
- 86** Flange Coupling UEF

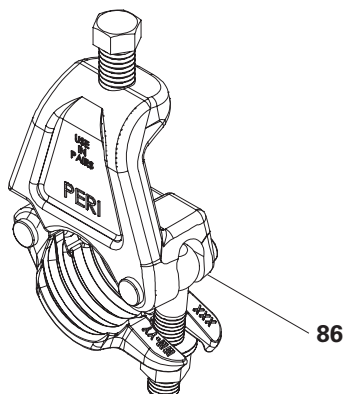
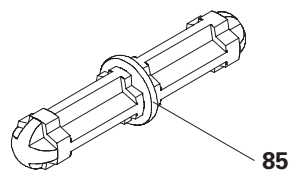
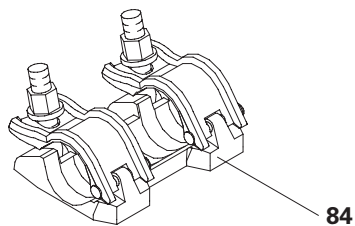
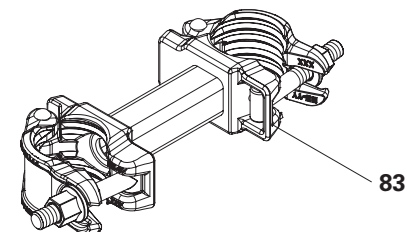
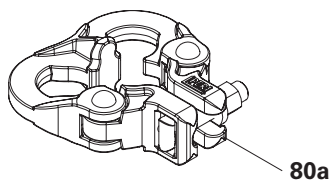
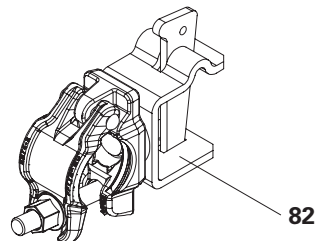
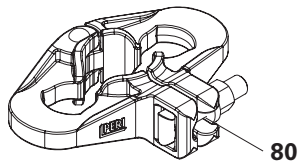

Clamping rosettes

e.g. for connecting horizontal ledgers between the welded rosettes of the standards.

Available as:

- Clamping Rosette UEV 180°
- Clamping Rosette UEV 90°.

Suitable for all scaffolding tubes with \varnothing 48.3 mm.

Total permissible load:

$F_s = 6.0$ kN.

The distribution of the total load on both ledger-to-ledger couplers is freely selectable.

Assembly

1. Open the screw connection of the Clamping Rosette UEV (**80/80a**).
2. Place the clamping rosette around the standard (**12**), align it in the system axis and close it.
3. Tighten the screw connection of the clamping rosette with 50 Nm.
→ Clamping rosette is installed.

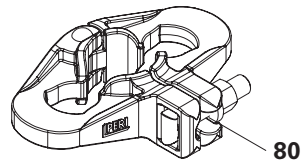

Fig. A10.01

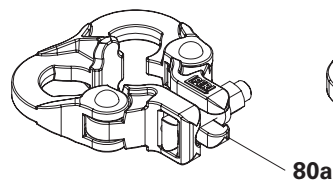

Fig. A10.02

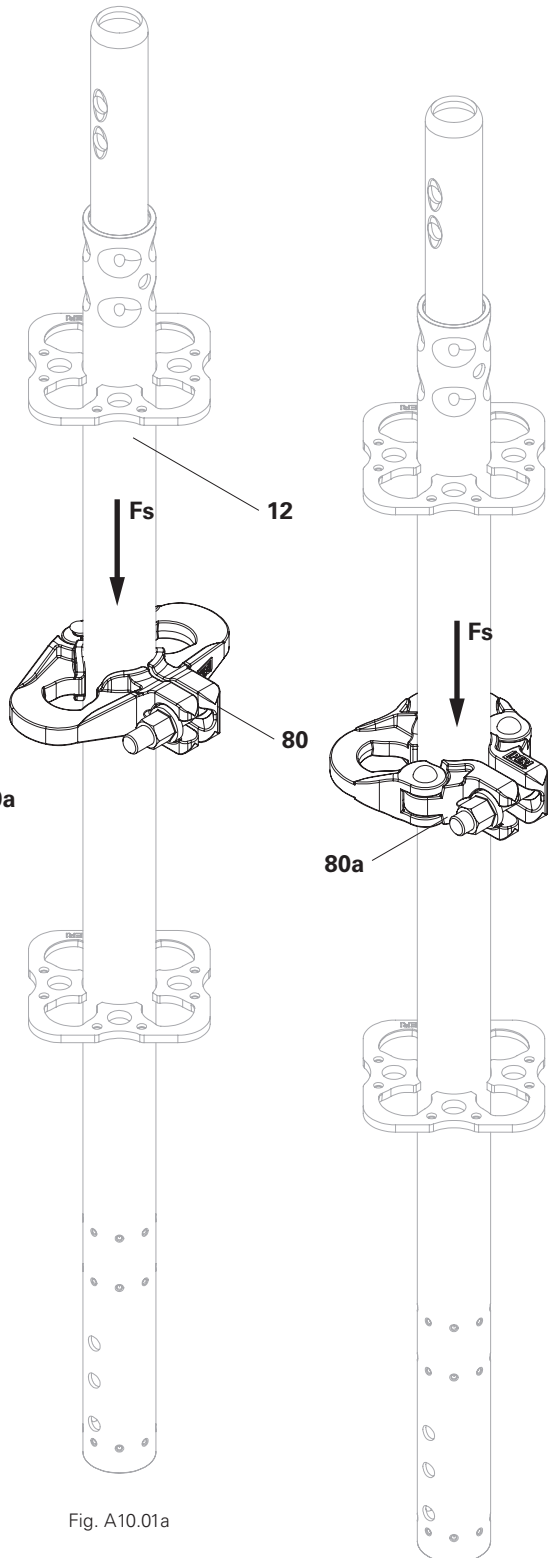

Fig. A10.01a

Fig. A10.01b

Coupling connection for UH 30/60

- The horizontal ledger serving as a support must be verified for these additionally introduced forces.
- For connecting scaffolding tubes $\varnothing 48.3$ mm to horizontal ledgers.
- Assembly can be carried out from above or from the side.
- The pipe coupling is freely rotatable at the clamping part.
- Permissible loads:
 $F_{\text{longitudinal}} \leq 0.67$ kN
 $F_{\text{transverse}} \leq 4.00$ kN
 The direction of tension between longitudinal and transverse to the horizontal ledger can be freely selected. The permissible values for F_Q and F_L must not be exceeded.

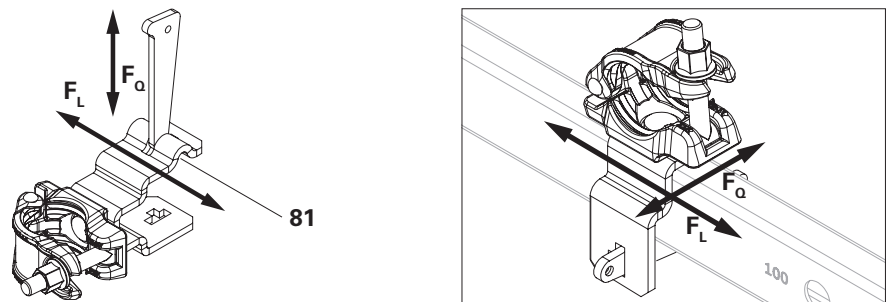

Fig. A10.03

Assembly

1. Pull the wedge (**81.1**) out of the clamping part and put the clamping part over the horizontal ledger (**14**) from the side or from above. (Fig. A10.03a)
2. Insert the wedge into the clamping part and hammer it tight. (Fig. A10.03b)
3. Fit the scaffolding tube (**145**) in the tube coupling (**81.2**). (Fig. A10.03b)
4. Tighten the coupling with 50 Nm.
 → Coupling connection is installed.

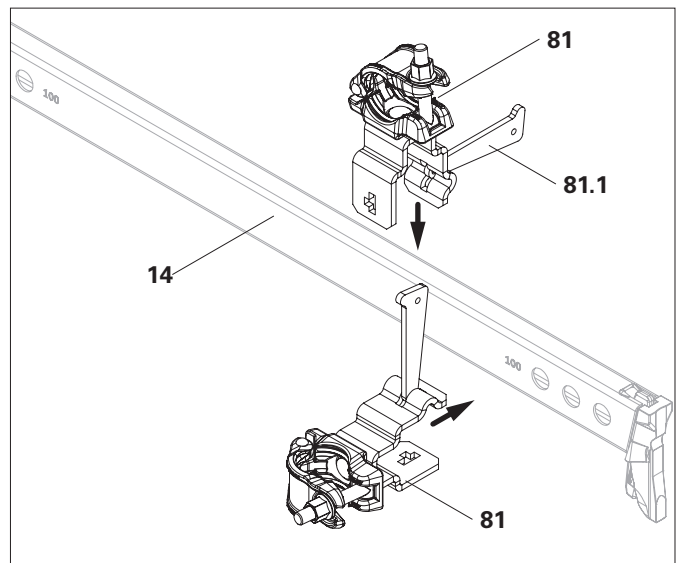

Fig. A10.03a

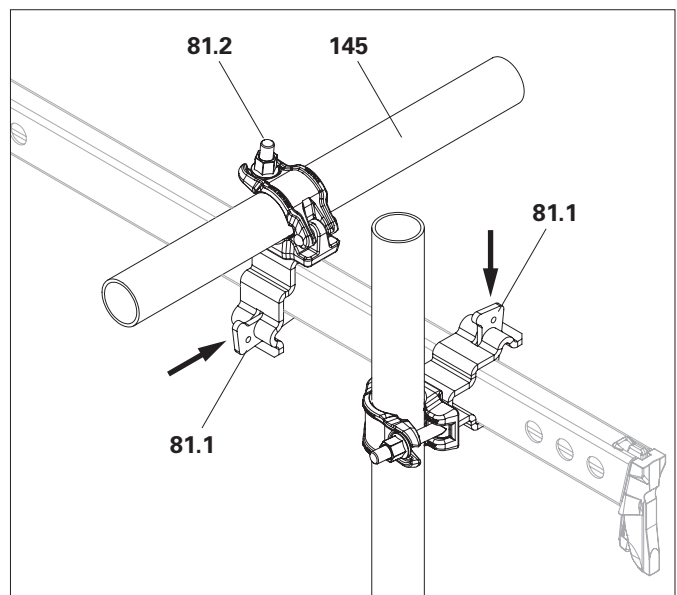

Fig. A10.03b

Application example

For bracing scaffold superstructures.

Coupling connection for UH

- The horizontal ledger serving as a support must be verified for these additionally introduced forces.
- For connecting scaffolding tubes $\varnothing 48.3$ mm to horizontal ledgers.
- The pipe coupling is freely rotatable at the clamping part.
- Permissible loads:
 $F_{\text{longitudinal}} \leq 0.67$ kN
 $F_{\text{transverse}} \leq 2.00$ kN
 The direction of tension between longitudinal and transverse to the horizontal ledger can be freely selected. The permissible values for F_Q and F_L must not be exceeded.

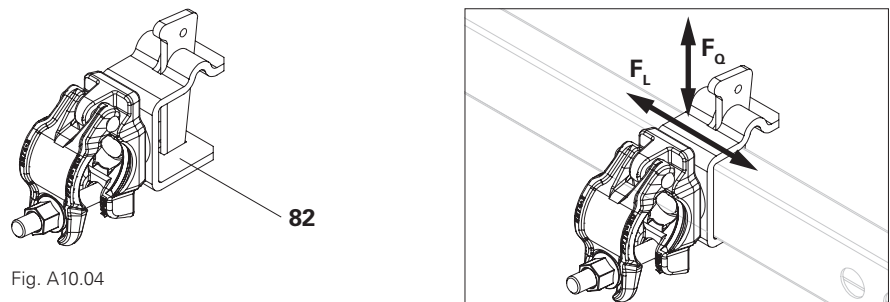

Fig. A10.04

Assembly

1. Pull the wedge (**82.1**) out of the clamping part and put the clamping part over the horizontal ledger (**14**) from the side. (Fig. A10.04a)
2. Insert the wedge into the clamping part and hammer it tight. (Fig. A10.04b)
3. Fit the scaffolding tube (**145**) in the tube coupling (**82.2**). (Fig. A10.04c)
4. Tighten the coupling with 50 Nm.
 → Coupling connection is installed.

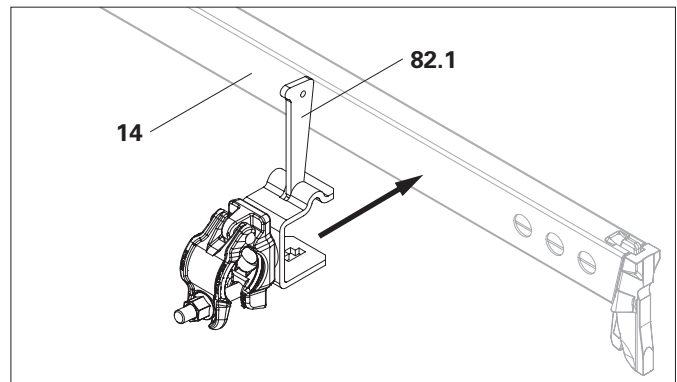

Fig. A10.04a

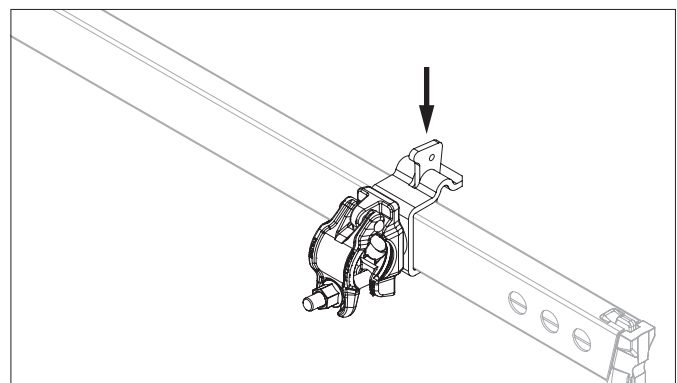

Fig. A10.04b

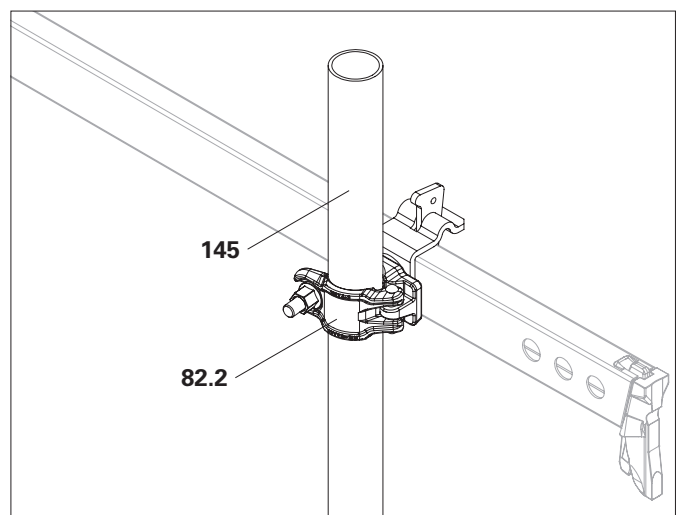

Fig. A10.04c

Application example

For bracing scaffold superstructures.

Spacer UEC-2

For connecting verticals \varnothing 48 mm.

Assembly

1. Position the verticals to be connected in such a way that the assembly can take place without tension.
2. Open both couplings of the Spacer UEC-2 (**83**) and mount it on the verticals.
3. Tighten the couplings with 50 Nm.
→ Spacer is installed. (Fig. A10.05a)

With the previous version Spacer UEC 10, the rosettes must be offset in height. (Fig. A10.05b)

Application example

For the structural connection of individual scaffolds that are not at right angles.

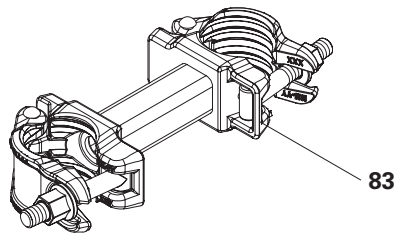

Fig. A10.05

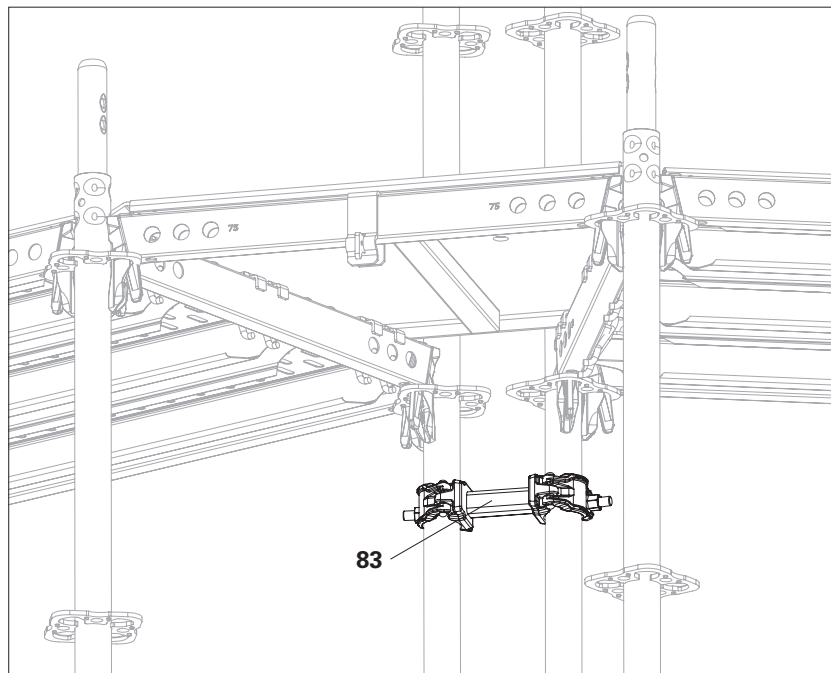

Fig. A10.05a

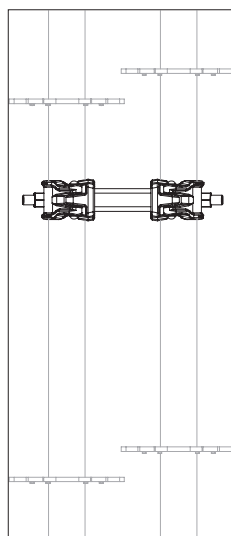

Fig. A10.05b

Tension coupler Ø 48.3 Tube connector Ø 48.3

The Ø 48.3 (84) tension coupler is used in conjunction with the Ø 48.3 (85) tube connector to extend scaffolding tubes.

Tension coupler Ø 48.3

Permissible loads:

Class A coupling

Permissible $F_{\text{Tension}} = 3.6 \text{ kN}$.

Connected scaffolding tubes have reduced tensile and compressive stability. Evidence of structural stability is always required.

Assembly

1. Insert tube connector (85) into scaffolding tube Ø 48.3 x 3.2 (145). (Fig. A10.07a)
 2. Attach another scaffolding tube to the second side of the tube connector.
 3. Connect scaffolding tubes with tension coupler (84). Tighten the couplings with 50 Nm. (Fig. A10.07b)
- Scaffolding tubes are connected.

Application example

Extension of scaffolding tubes and anchors.

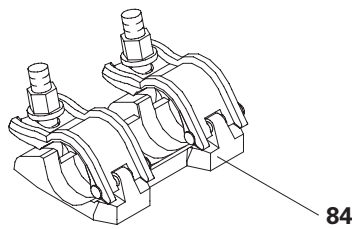

Fig. A10.06

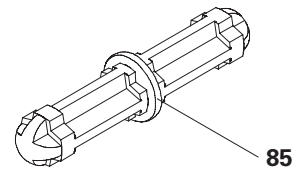

Fig. A10.06

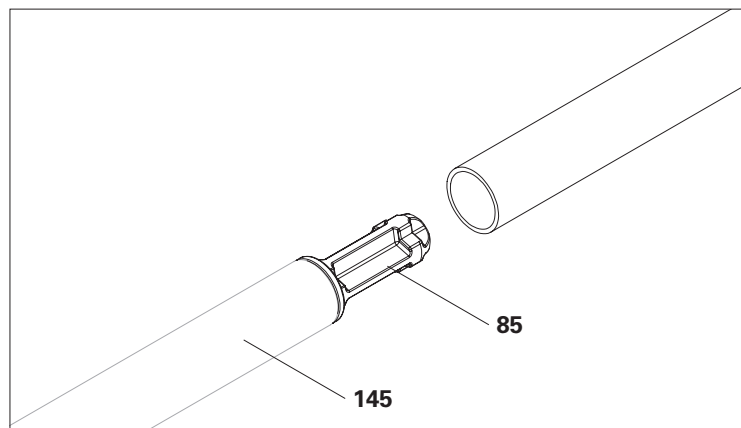

Fig. A10.07a

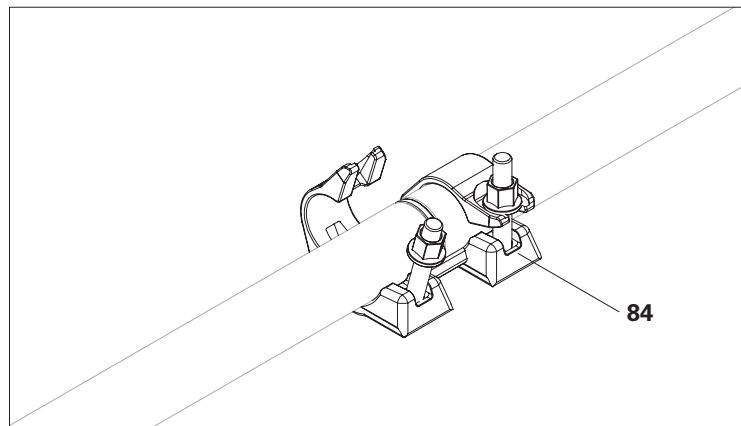

Fig. A10.07b

Flange Coupling UEF

For connecting scaffolding tubes to flange supports.

Flange Couplings UEF (**86**) can be used on horizontal flange supports for suspended scaffolds or on vertical flange supports as scaffold ties. (Fig. A10.10)

Only use Flange Couplings UEF in pairs and in clamps. The scaffolding tube serves as a basis for further construction with a system scaffold.

Technical data

Flange width: $bf \geq 31 \text{ mm}$

Flange thickness: $tf \leq 36 \text{ mm}$

(Fig. A10.11)

For permissible attachment loads see Table "Tab. A10.01" on page 116 and "Tab. A11.01" on page 119.



Risk of confusion

The Flange Coupling UEC (**116**) (Fig. A10.09) has been replaced by the Flange Coupling UEF (**86**). The Flange Coupling UEC can still be used, but has a lower load capacity compared to the Flange Coupling UEF. It may only be mounted on horizontal flange supports.



- The load-bearing capacity of the flange supports must be verified individually.
- Flange couplings must be pushed onto the flange support up to the stop in order to keep the bending stress low.
- Additionally verify the introduction and transmission of the forces into the steel supports. You can limit the permissible load of the entire connection!
- The verifications for the scaffolding tube must be carried out additionally and are not included in the specified permissible loads!

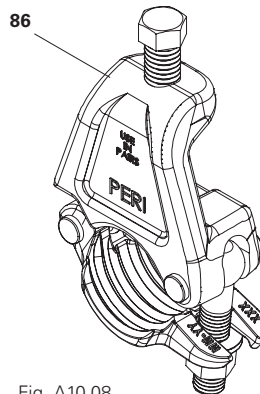

Fig. A10.08

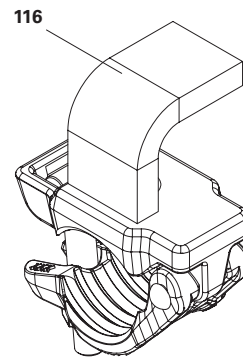

Fig. A10.09

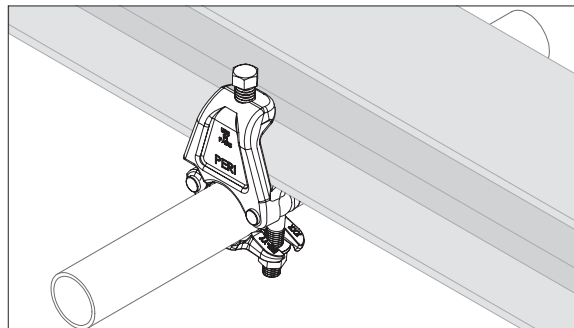

Fig. A10.10

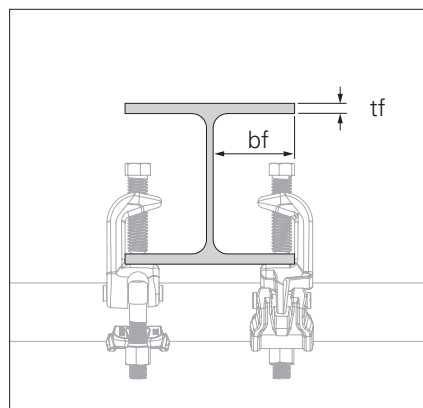

Fig. A10.11

Flange couplings on horizontal flange supports

e.g. for assembly of a suspended scaffold.

Variant 1

Two flange couplings mounted on a flange support on both sides.
(Fig. A10.12a)

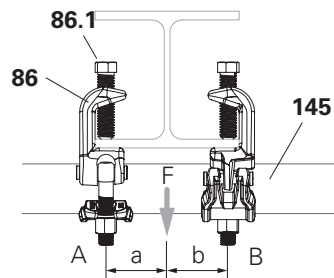

Fig. A10.12a

Variant 2

Two flange couplings mounted on the outside of two flange supports.
(Fig. A10.12b)

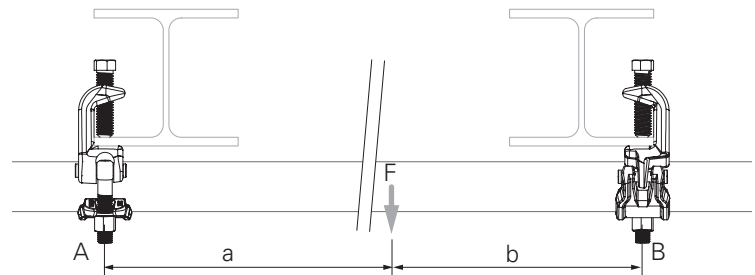

Fig. A10.12b

Variant 3

Two flange couplings mounted on two flange supports. (Fig. A10.12c)

Assembly

1. Open fixing screws (**86.1**) on flange clamping piece (**86**) of flange couplings.
 2. Place two flange couplings alternately on a scaffolding tube (**145**). Tighten the half-coupling of one flange coupling with 50 Nm, do not tighten the other.
 3. Push the scaffolding tube with fixed flange coupling onto the flange support up to the stop.
 4. Push the second flange coupling against the flange support.
 5. Tighten the screw of the second half-coupling with 50 Nm.
 6. Tighten the fixing screws.
- Flange couplings are installed.

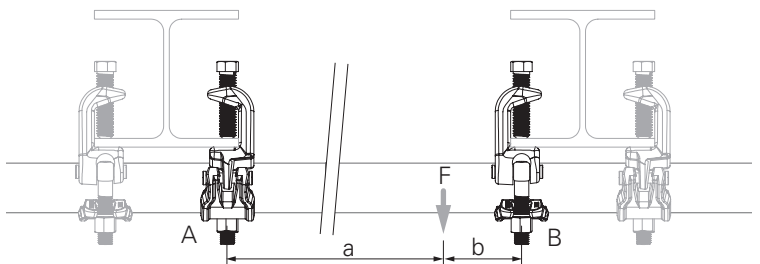

Fig. A10.12c



The greyed out flange couplings (Fig. A10.12c) do not allow any further load increase!

The permissible attachment load is determined by the division of the distance into sections a and b.

The maximum attachment load is achieved centrally between the flange couplings.

For further breakdowns see Table A10.01

Application example

For suspended scaffolds, see Instructions for Assembly and Use "PERI UP Flex Suspended Scaffold".

Permissible suspended loads between two flange couplings							
Allocation		Flange Coupling UEF			Flange Coupling UEC-2		
a [%]	b [%]	max. F [kN]	max. A [kN]	max. B [kN]	max. F [kN]	max. A [kN]	max. B [kN]
100	0	15.00	0.00	15.00	9.00	0.00	9.00
90	10	16.67	1.67	15.00	10.00	1.00	9.00
80	20	18.75	3.75	15.00	11.25	2.25	9.00
70	30	21.43	6.43	15.00	12.86	3.86	9.00
60	40	25.00	10.00	15.00	15.00	6.00	9.00
50	50	30.00	15.00	15.00	18.00	9.00	9.00
40	60	25.00	15.00	10.00	15.00	9.00	6.00
30	70	21.43	15.00	6.43	12.86	9.00	3.86
20	80	18.75	15.00	3.75	11.25	9.00	2.25
10	90	16.67	15.00	1.67	10.00	9.00	1.00
0	100	15.00	15.00	0.00	9.00	9.00	0.00
		= A + B	≤ 15.00	≤ 15.00	= A + B	≤ 9.00	≤ 9.00

Tab. A10.01

Installing as vertical coupling

The following loads only apply when the suspension is positioned centrally between the flange couplings.



- Slip force: Vertical:
max. perm. $F_v = 3.4 \text{ kN}$.
Horizontal: max. perm. $F_H = 6.0 \text{ kN}$

Assembly

- Place two Flange Couplings UEF (86) alternately on a scaffolding tube (145). Tighten only one half-coupling.
 - Open the fixing screws on both flange clamping pieces.
 - Push the flange coupling mounted on the scaffolding tube onto the flange support up to the stop.
 - Tighten the fixing screw as far it will go by hand.
 - Push the second flange coupling onto the flange support up to the stop.
 - Tighten the fixing screw.
 - Tighten the half-coupling with 50 Nm.
 - Tighten the fixing screw of the first flange coupling.
- Flange couplings are installed.

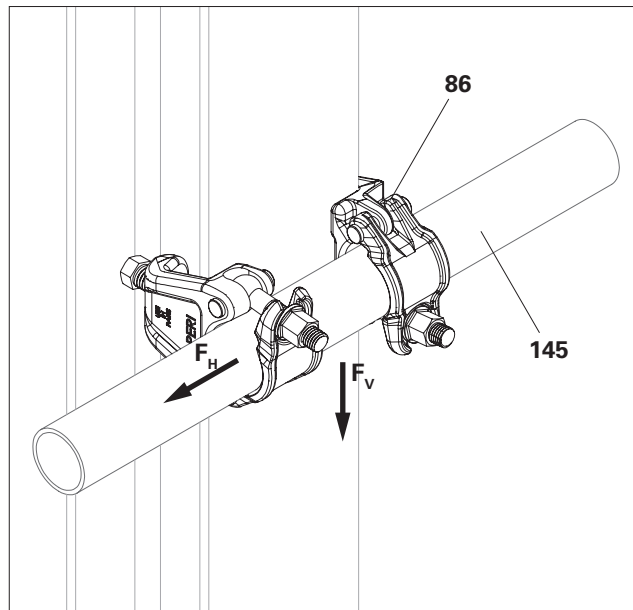

Fig. A10.13

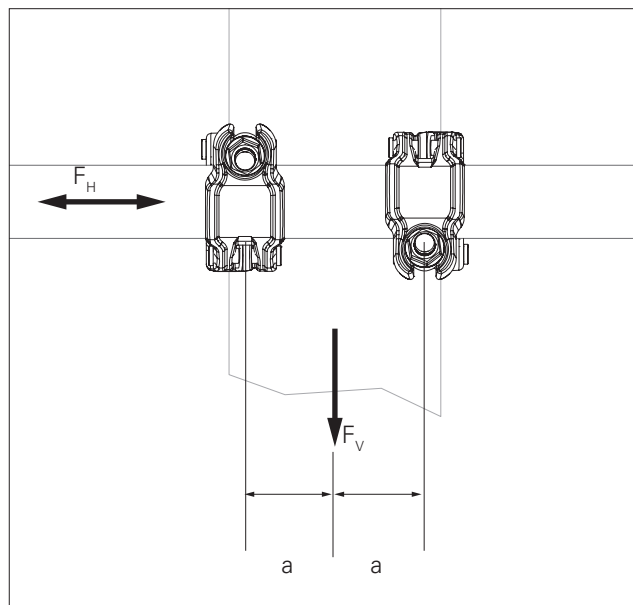
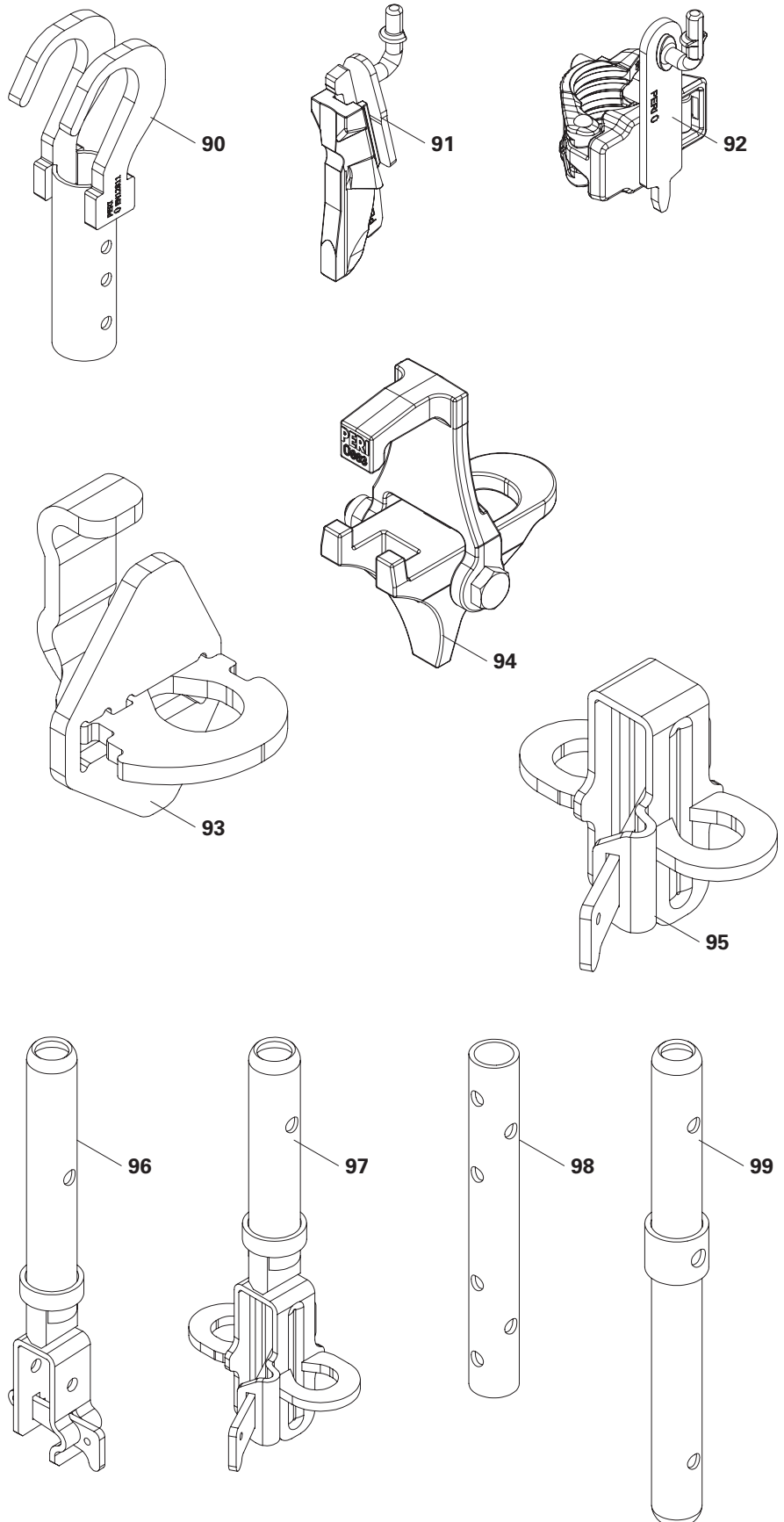

Fig. A10.13a

General

Components

- 90 Adapter Suspended Scaffold UEH
- 91 Guardrail Holder EPW
- 92 Guardrail Coupling EPR
- 93 Ledger-to-Ledger Coupler UHA
- 94 Ledger-to-Ledger Coupler UHA-2
- 95 Ledger-to-Ledger Coupler UHA Half
- 96 UH Spigot-2
- 97 Ledger-to-Ledger Coupler UHA-2 Half with Spigot
- 98 Connector ULT 32
- 99 Pin with Spacer Tube URE 4/42



Adapter Suspended Scaffold UEH

With the Adapter Suspended Scaffold EH (90), verticals can be suspended as a suspended scaffolding construction.



- For permissible attachment loads and the fasteners required for the tension joints, see Table "Tab. A2.01" on page 36. All maximum values can be absorbed according to the table.
- Pay attention to the permissible bending of the scaffolding tube.
- Adapter may only be mounted between two flange couplings.

Installing on scaffolding tube directly under flange support

1. Set Adapter Suspended Scaffold UEH at an angle of approx. 45° and push claws (90.1) between the scaffolding tube and flange support. The round inner contour of the adapter suspended scaffold must lie against the scaffolding tube. (Fig. A11.01a)
2. Swing the adapter suspended scaffold down vertically. (Fig. A11.01b)
- Adapter suspended scaffold is installed.
- Adapter and scaffold are secured against lifting.
3. Attach the suspended scaffold with locking pin and self-locking nuts in one of the holes (90.2). (Fig. A11.01c)
4. The connection is made either with the pin of the UVR or, in the case of the top standard, with the Connector ULT.

Application example

Suspended scaffolds, see Instructions for Assembly and Use "PERI UP Flex Suspended Scaffold"

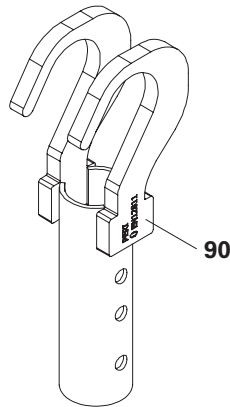

Fig. A11.01

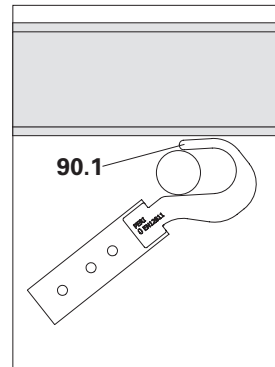

Fig. A11.01a

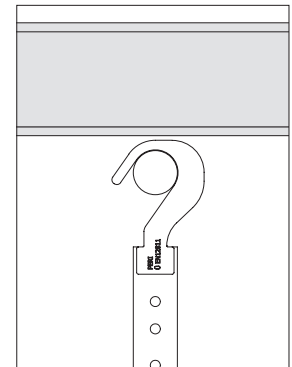

Fig. A11.01b

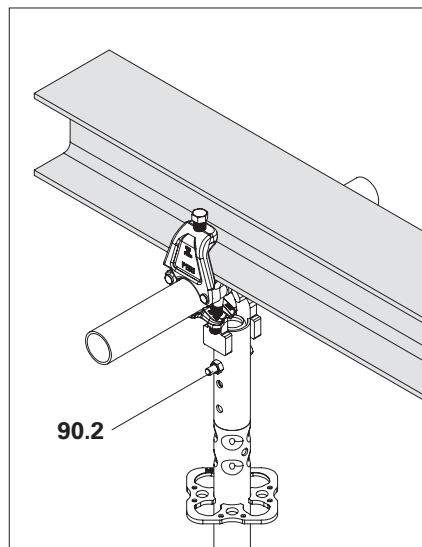

Fig. A11.01c

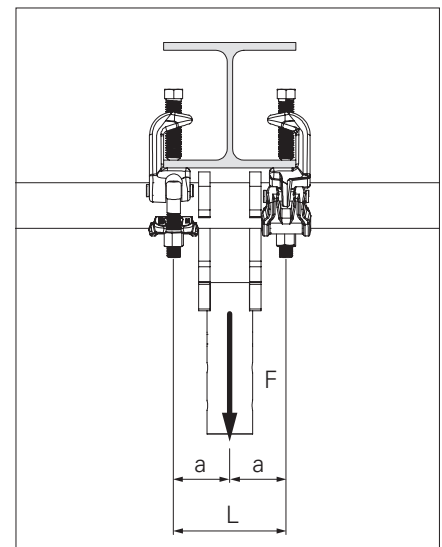

Fig. A11.01d

Permissible attachment load on a flange beam on scaffolding tube traverse min. 48.3 x 3.2 – S235/320

Span L [mm]	UEF Perm. F [kN]*	UEC Perm. F [kN]*
320.0	16.9	16.9
300.0	18.2	18.0
280.0	19.6	18.0
260.0	21.3	18.0
240.0	23.3	18.0
220.0	25.7	18.0
200.0	28.6	18.0
191.4	30.0	18.0
80.0	30.0	18.0

*The specified loads only apply when the suspension is positioned centrally between the flange couplings and directly under the flange support

Tab. A11.01

Installing on free scaffolding tube or formwork girder

1. Installing Flange Coupling UEF as described in the Section Flange Coupling UEF.
2. Assembly of Adapter UEH (90) as described under Adapter Suspended Scaffold UEH.
3. Install the opposite Adapter UEH (90a) turned 180°. Hook openings must not point in the same direction. (see Fig. A11.02)
4. Install verticals and ledgers.



- The scaffolding tube must be verified separately.
- The values given in the table in the previous Section are not valid in this application.

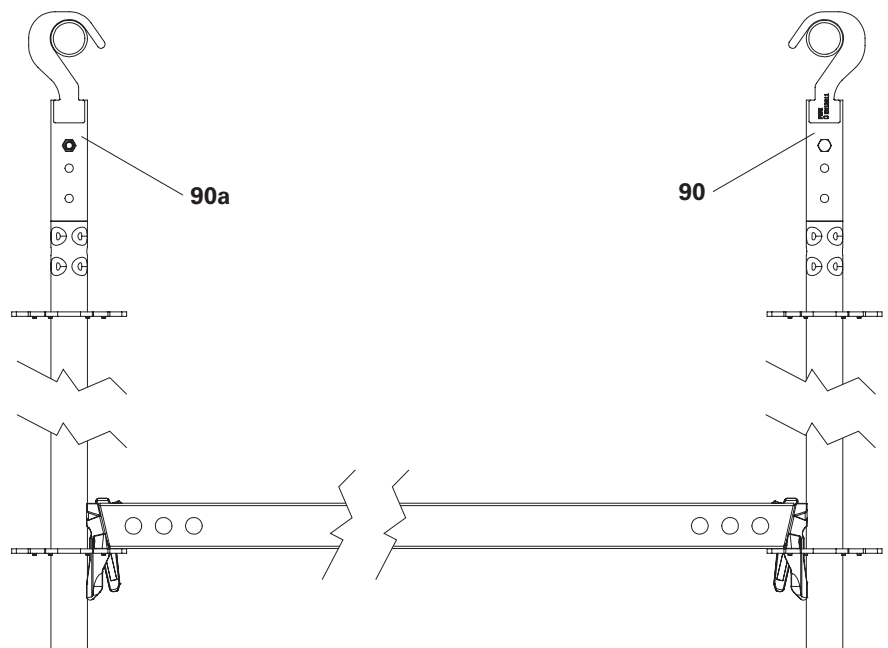

Fig. A11.02

Guardrail Holder EPW

- Install the Guardrail Holder EPW (**91**) so that the guardrail hangs on the deck side of the scaffold.
- 2 Guardrail Holders EPW can be hung overlapping on each guardrail post.

Assembly

1. Insert Guardrail Holders EPW (**91**) into the rosettes of the Standards UVR-2. Guardrail hooks must point inwards towards the deck. Secure the wedges. (Fig. A11.03a)
→ Guardrail Holder Kit EPW is installed.
2. Hang the Guardrail Posts EPG (**33**) and intermediate guardrails on the guardrail hooks. (Fig. A11.03b + A11.03c)

Application example

Installation of a guardrail in advance.

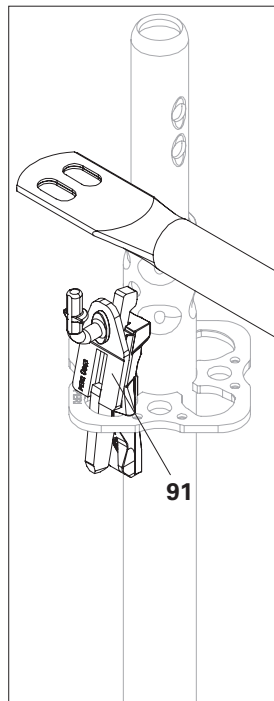

Fig. A11.03a

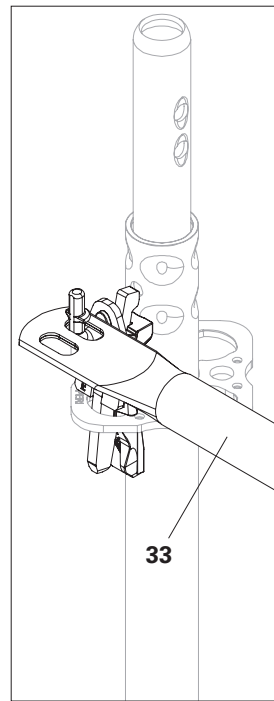

Fig. A11.03b

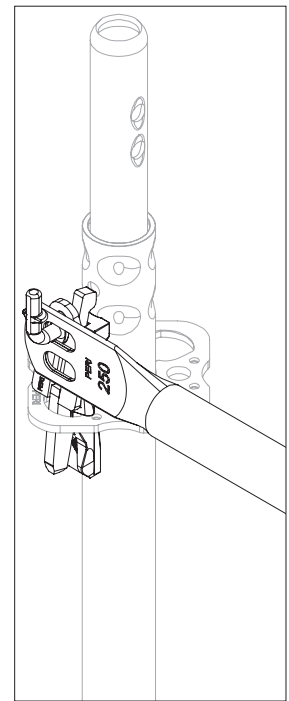

Fig. A11.03c

Guardrail Coupling EPR

- Install the Guardrail Coupling EPR (92) so that the guardrail hangs on the deck side of the scaffold.
- 2 Guardrail Posts EPG can be hooked in overlapping on each guardrail coupling.

Assembly

1. Screw the guardrail coupling with guardrail hook (92.1) to the top of the vertical. Tighten the coupling with 50 Nm. (Fig. A11.04a)
→ Guardrail coupling is installed.
2. Hang the Guardrail Posts EPG (33) and intermediate guardrails on the guardrail hooks. (Fig. A11.04b)

Application example

Installing a guardrail in advance at any point of verticals.
Securing console brackets against lifting off.

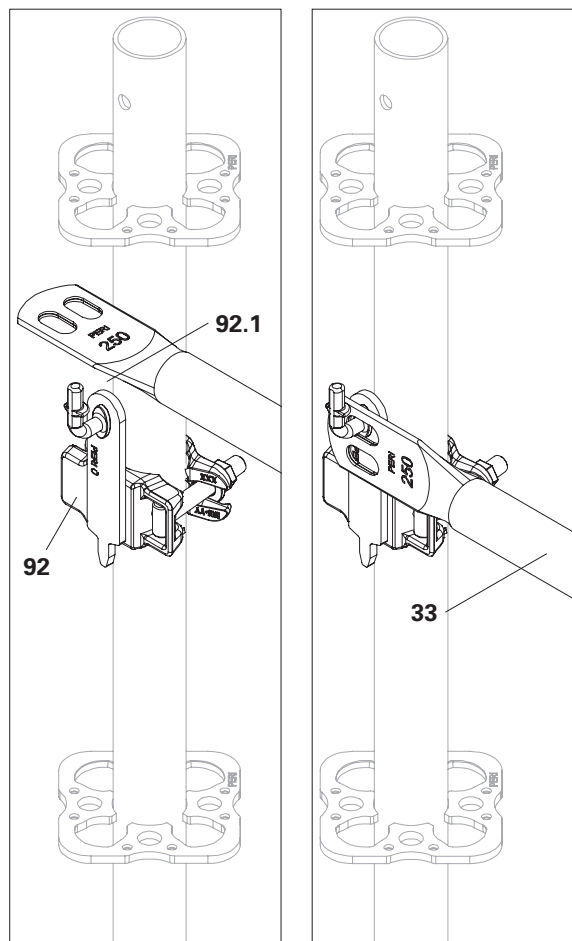

Fig. A11.04a

Fig. A11.04b

Ledger-to-Ledger Coupler UHA

- Perm. F = 1.67 kN (Fig. A11.06)
- The horizontal ledger serving as a support must be verified for these additionally introduced forces.
- The Ledger-to-Ledger Coupler UHA (**93**) can be installed on the Horizontal Ledgers UH (Fig. A11.06a) and on the reinforced Horizontal Ledgers UHV (Fig. A11.06b).
- The Ledger-to-Ledger Coupler UHA is not suitable for cantilevered components.

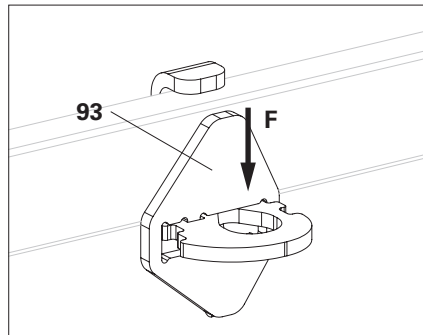

Fig. A11.06

Assembly

1. Place the suspension (**93.1**) of the Ledger-to-Ledger Coupler UHA (**93**) on the horizontal ledger (**14**) and hold it with one hand. (Fig. A11.06c)
 2. Lift the pressure plate (**93.2**) and push it towards the horizontal ledger (**14**). (Fig. A11.06d – A11.06f)
 3. Insert the locking finger (**93.3**) into the hole. (Fig. A11.06g + A11.06h)
 4. Hook the horizontal ledger (**14a**) from above into the Ledger-to-Ledger Coupler UHA (**93**). (Fig. A11.06i)
 5. Knock in the wedges of the horizontal ledgers firmly. (Fig. A11.06j)
- Ledger-to-ledge coupler is installed.

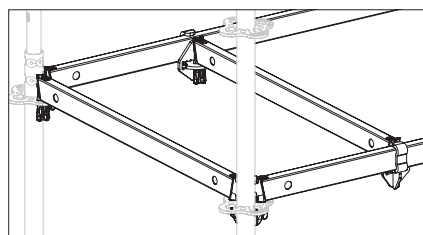

Fig. A11.06a

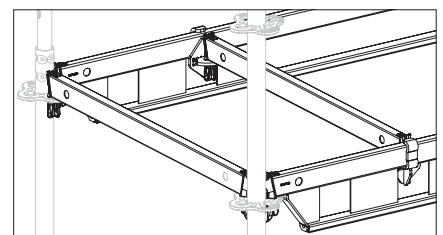

Fig. A11.06b

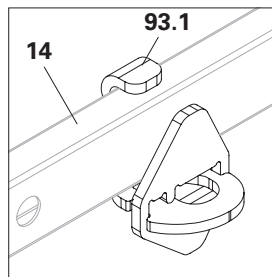

Fig. A11.06c

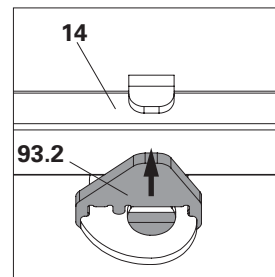

Fig. A11.06d

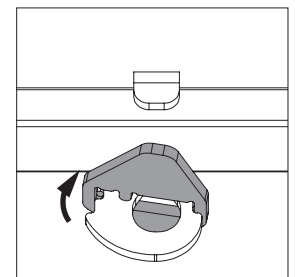

Fig. A11.06e

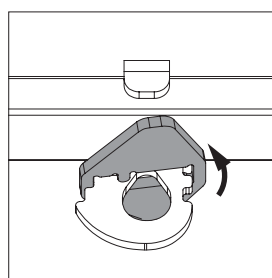

Fig. A11.06f

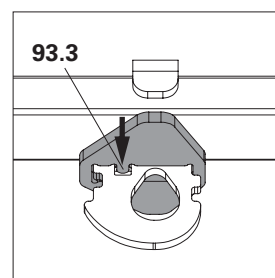

Fig. A11.06g

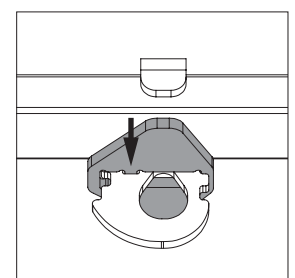

Fig. A11.06h

Application example

The Ledger-to-Ledger Coupler UHA is mounted in order to install a horizontal ledger between two available ledgers at the same height.

This is applied in order to:

- install a passage,
- provide an additional support for decking,
- change the direction of the decks.

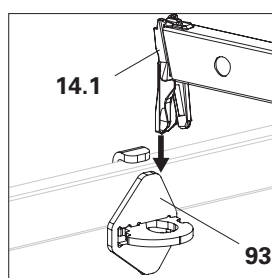

Fig. A11.06i

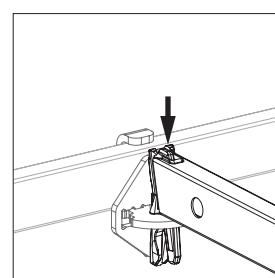

Fig. A11.06j

Ledger-to-Ledger Coupler UHA-2

- Perm. $F = 10 \text{ kN}$
Perm. $M_y = 35 \text{ kNcm}$
- The horizontal ledger serving as a support must be verified for these additionally introduced forces.
- The Ledger-to-Ledger Coupler UHA-2 replaces the previous version as described above.
- The possible installation positions remain unchanged.

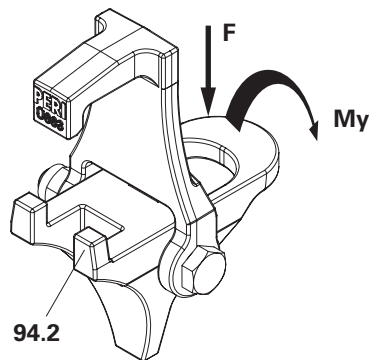

Fig. A11.07

Assembly

1. Unfold the Ledger-to-Ledger Coupler UHA-2 (94), push it onto the horizontal ledger (14) and release it.
→ Ledger-to-ledge coupler (94.1) tilts into horizontal position and holds the ledger-to-ledge coupler in place. (Fig. A11.07a + A11.07b)
2. Pull the ledger-to-ledge coupler up so that both lugs (94.2) are in contact with the horizontal ledger.
3. Install the horizontal ledger (14a) in the ledger-to-ledge coupler.
→ The ledger-to-ledge coupler is clamped by the wedge.
→ Ledger-to-ledge coupler is installed. (Fig. A11.07c)

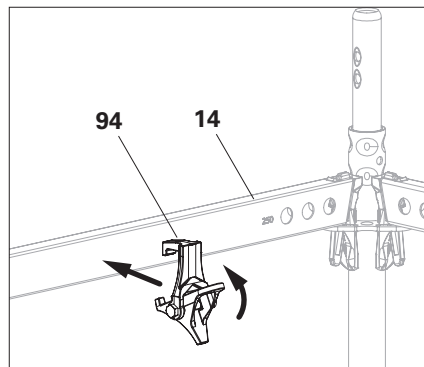

Fig. A11.07a

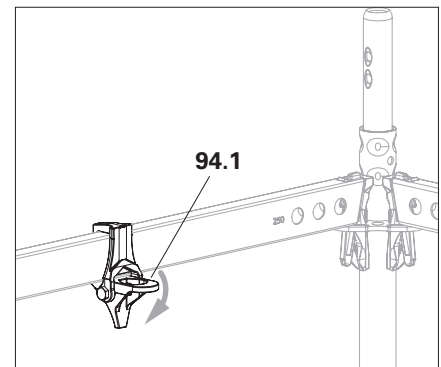

Fig. A11.07b

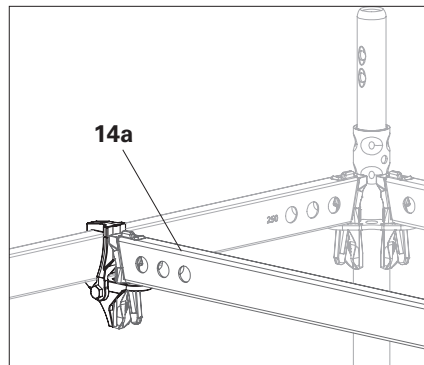

Fig. A11.07c

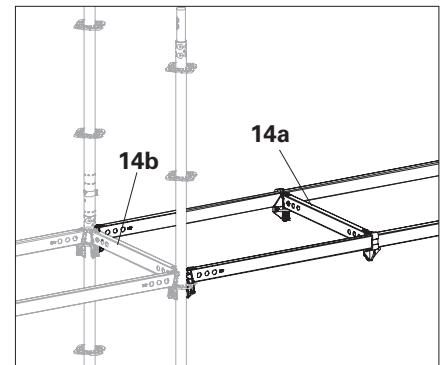

Fig. A11.07c



- Due to increased load requirements, the assembly tolerances are very low. When installing a horizontal ledger (14a) that is secured on both sides, knock the horizontal ledgers (14b) running parallel to it into place last. (Fig. A11.07c)
Alternatively, fit the ledger-to-ledge couplers in a slightly offset manner, insert the horizontal ledger (14a), align the ledger-to-ledge couplers and hammer the wedges in place.
- The drophead wedge will not fall automatically if the ledger-to-ledge coupler is not mounted correctly.

Application example

See the Ledger-to-Ledger Coupler UHA.

Ledger-to-Ledger Coupler UHA half

- Permissible F per ledger-to-
ledger coupler = 8.44 kN.
- The horizontal ledger serving as a
support must be verified for these
additionally introduced forces.

Assembly

1. Pull the wedge out of the clamping
part and put the clamping part over
the horizontal ledger (**14**).
(Fig. A11.08a)
2. Insert wedge into clamping part,
do not yet tighten.
3. Hook the horizontal ledger (**14a**)
from above into the Ledger-to-
Ledger Coupler UHA Half (**95**),
do not tighten the wedges yet.
4. Install other position-determining
components, e.g. decks.
5. Hammer all wedges into place.
→ Ledger-to-
ledger coupler is installed.
(Fig. A11.08b)

Application example

For right-angled connection of
two opposite horizontal ledgers to one
horizontal ledger.

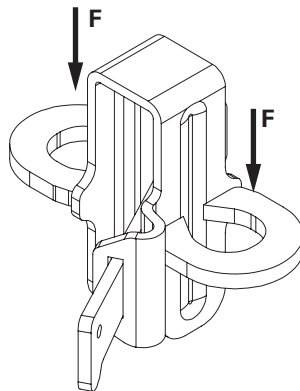

Fig. A11.08

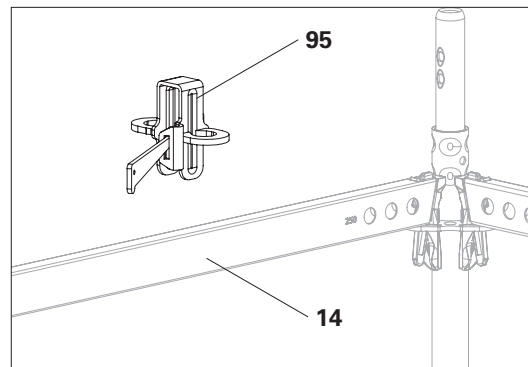

Fig. A11.08a

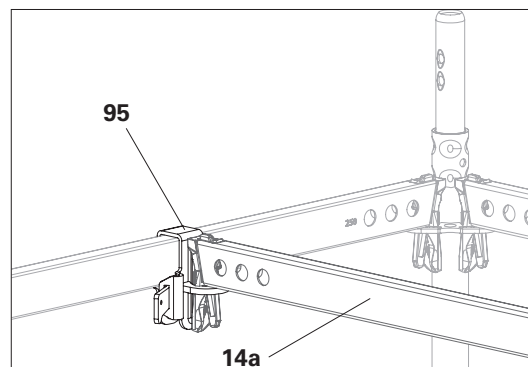

Fig. A11.08b

UH Spigot-2

With the UH Spigot-2 (96), it is possible to continue building with verticals on horizontal ledgers.

- For absorbing vertical loads from verticals and introduction into the horizontal ledger.
- The horizontal ledger serving as a support must be verified for these additionally introduced forces.
- Its use as a support for a free-standing guardrail post is only possible if the free guardrail post is connected to a torsionally stiff standard (12) with 2 horizontal ledgers ≤ 2.25 m (14). The standard (12) must be held by further horizontal ledgers (14a) extending at an angle of 90° . (Fig. A11.09)
Otherwise, note "Installing verticals when using Guardrail Posts EPG" on page 130.
- Perm. max. lateral force $F_H = 5$ kN, Perm. max. moment $M_{\perp} = 0.17$ kNm. Only the moment or the lateral force with the maximum values may be introduced. If moment and shear force are superimposed, the component must be verified separately. (Fig. A11.09a)

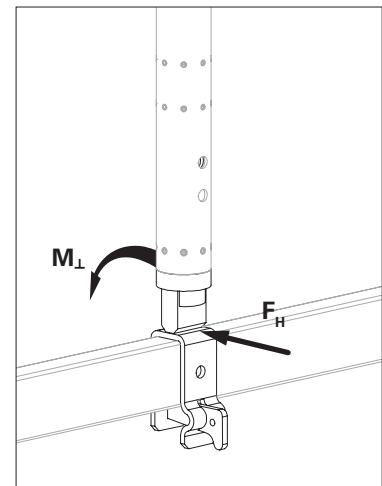
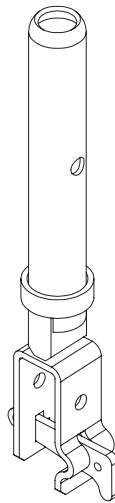

Fig. A11.09a

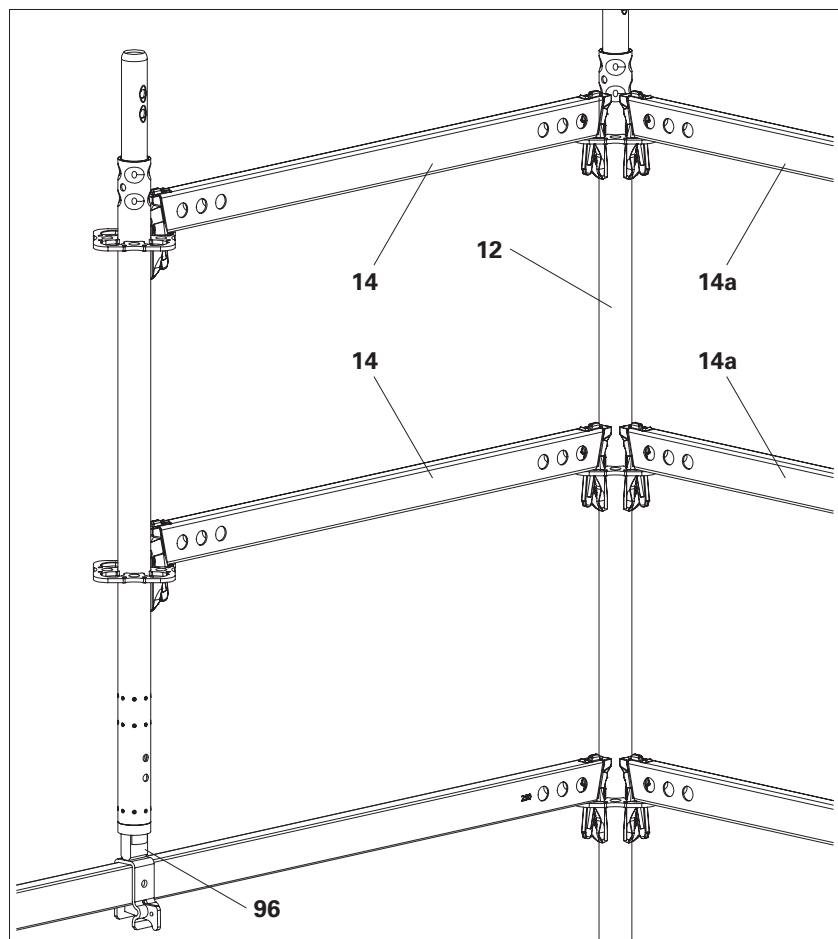

Fig. A11.09

Assembly

1. Pull the wedge (**96.1**) out of the clamping part and put the clamping part over the horizontal ledger. (Fig. A11.09b)
 2. Insert wedge into clamping part, do not yet tighten.
 3. Fit standard (**12**) on UH Spigot (**96**). (Fig. A11.09c)
 4. Install other components that determine the position, e.g. horizontal ledger, and align the UH Spigots exactly according to this.
 5. Tighten all wedges (**96.1**). (Fig. A11.09d)
- UH Spigot is mounted.

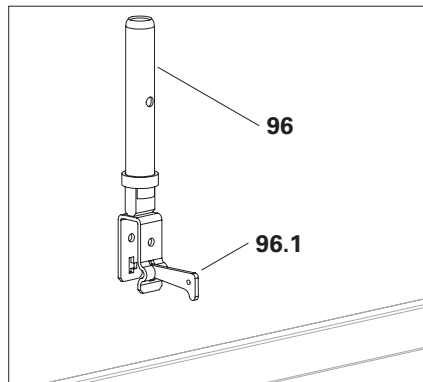

Fig. A11.09b

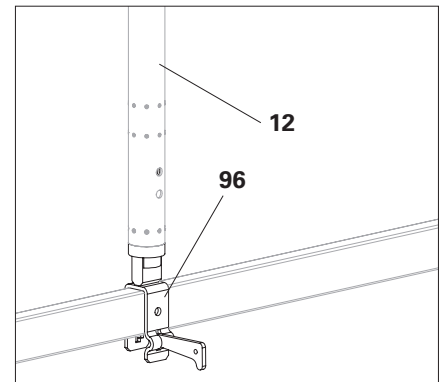

Fig. A11.09c

Application example

For assembly of standards.



- The function of the guardrail is only guaranteed when all the wedges have been tightened.
- The predecessor component UH Spigot does not fit in
 - Standards UVR-2
 - all Easy vertical components.

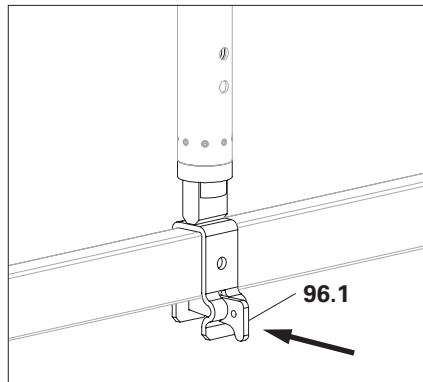

Fig. A11.09d

Ledger-to-Ledger Coupler UHA-2 Half with Spigot

The Ledger-to-Ledger Coupler UHA-2 Half with Spigot (**97**) can be used to continue construction with verticals and horizontal ledgers on or at horizontal ledgers.

- For absorbing vertical loads from verticals and introduction into the horizontal ledger.
- The horizontal ledger serving as a support must be verified for these additionally introduced forces.
- Its use as a support for a free-standing guardrail post is only possible if the free guardrail post is connected to a torsionally stiff standard (**12**) with 2 horizontal ledgers ≤ 2.25 m (**14**). The standard (**12**) must be held by further horizontal ledgers (**14a**) extending at an angle of 90° . (Fig. A11.10) Otherwise, note "Installing verticals when using Guardrail Posts EPG" on page 130.
- Perm. F per ledger-to-ledger coupler = 8.44 kN
- Perm. max. lateral force $F_H = 5$ kN, Perm. max. moment $M_\perp = 0.17$ kNm. Only the moment or the lateral force with the maximum values may be introduced. If moment and shear force are superimposed, the component must be verified separately. (Fig. A11.10a)

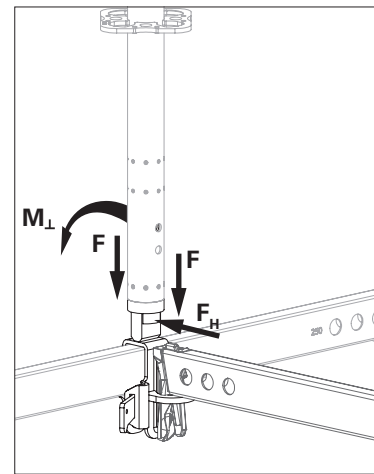
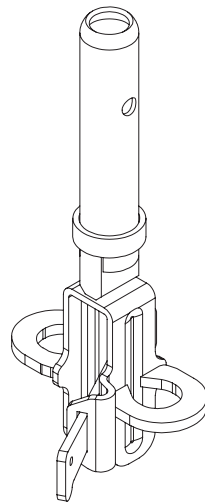

Fig. A11.10a

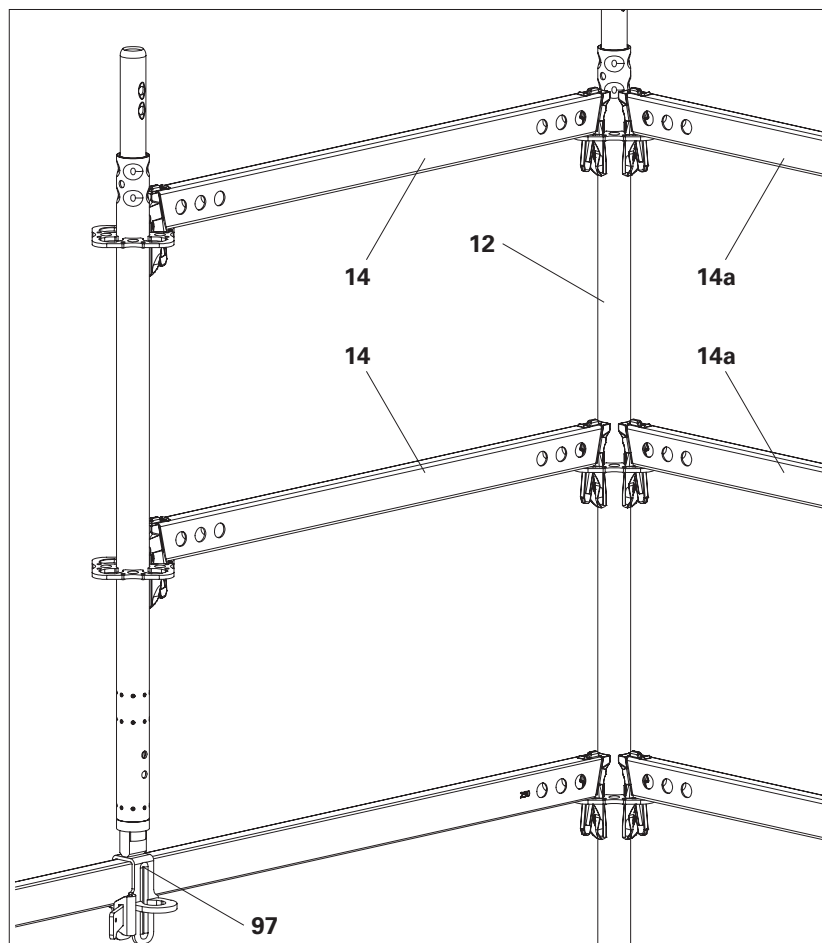

Fig. A11.10

Assembly

1. Pull the wedge out of the clamping part and put the clamping part over the horizontal ledger (**14**).
(Fig. A11.10b)
2. Insert wedge (**97.1**) into clamping part, do not tighten yet.
3. Fit the standard onto the UH Spigot (**97**).
4. Install other components that determine the position, e.g. horizontal ledger, and align the ledger-to-ledger coupler exactly according to this.
5. Hook the horizontal ledger (**14a**) from above into the Ledger-to-Ledger Coupler UHA Half (**97**).
6. Hammer all wedges into place.
→ Ledger-to-ledger coupler is installed.
(Fig. A11.10c)

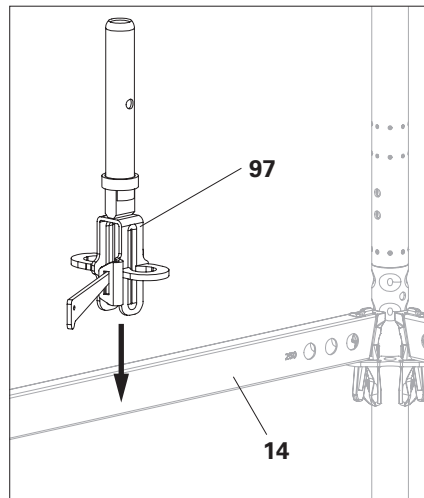

Fig. A11.10b

Application example

For right-angled connection of two opposite horizontal ledgers and a standard to one horizontal ledger.



- The function of the guardrail is only guaranteed when all the wedges have been tightened.
- The predecessor component Ledger-to-Ledger Coupler UHA with spigot does not fit in
 - Standards UVR-2
 - all Easy vertical components.

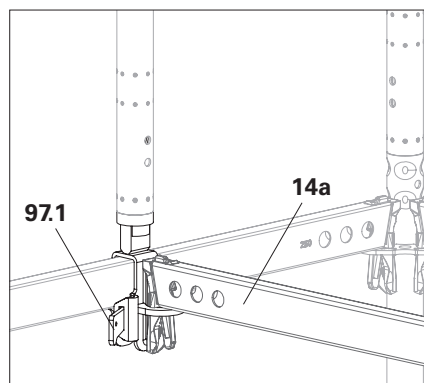

Fig. A11.10c

Installing verticals when using Guardrail Posts EPG

Required for UH Spigot-2 (**95**) and Ledger-to-Ledger Coupler UHA-2 Half with Spigot (**97**) and their predecessor models.

Guardrail Posts EPG have no bracing effect on the free-standing standard. It is therefore imperative that the body is braced.

- The UH Spigot-2 or the Ledger-to-Ledger Coupler UHA-2 Half with Spigot and their predecessor models will otherwise be overloaded.
- The free-standing standard does not otherwise have the necessary bracing as a guardrail post.

Installation example

1. Install the free-standing standard (**12**), e.g. UVR + EPW or Easy Standard EVM 200, starting 1 m below the deck level on the horizontal ledger (**14**) and UH Spigot-2 (**95**).
2. Install 2 suitable horizontal ledgers (**14a + 14b**) at platform level. (Fig. A11.11)



- Verify the load-bearing capacity of the horizontal ledger (**14**). If necessary, install a Horizontal Ledger UHV.
- Install the decks (**50**) at right angles to the access side. Otherwise they will collide with the free-standing standard (**12**).
- If the deck is installed parallel to the access side: For horizontal bracing, additionally install a Horizontal Brace UBH Flex (**20**) or a scaffolding tube with standard couplers.
- Note the limited selection of Horizontal Braces UBH Flex.
- For further installation examples, see the respective system-specific Instructions for Assembly and Use.

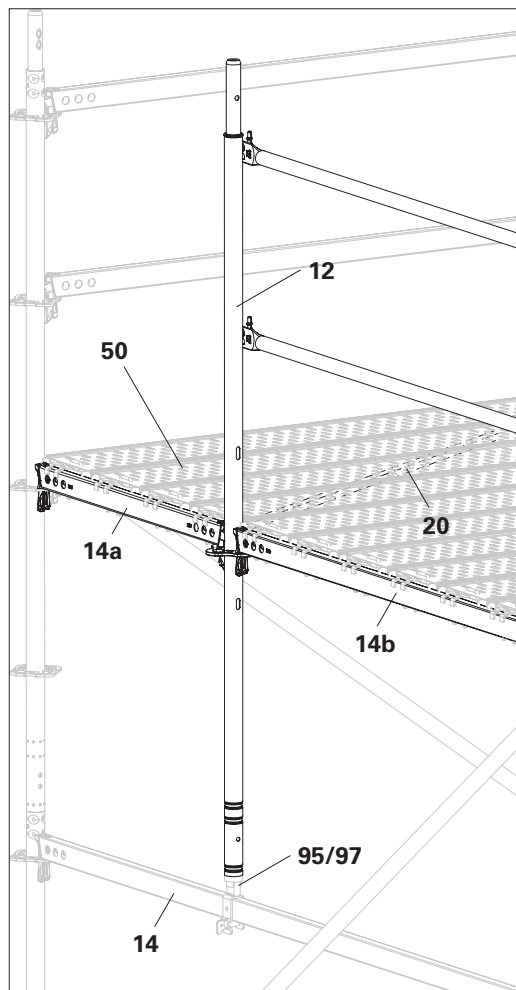

Fig. A11.11

Connector ULT

For connecting Formwork Girders ULA/ ULS or for further construction on top standards.

- Perm. Z per upper and lower chord in combination with 1 x Connector ULT and 4 x bolt M10 x 70 – 8.8 and nut
 - ULA = 37.4 kN.
 - ULS = 42.2 kN.
- For permissible tensile forces for connecting standards, see Section “Tensile couplings” on page 36.

Assembly

1. Insert two Connectors ULT (**98**) into formwork girders and mount each with 2 screws M10 x 70-8.8 with nut.
 2. Fit the second formwork girder onto the Connectors ULT and mount each with 2 screws M10 x 70-8.8 with nut. (Fig. A11.12a)
- Connector ULT is installed.

For further assembly on top standards, the Connector ULT can be staked out with locking pins \varnothing 48.3/57 or bolts and nuts.



If both verticals are to be pinned (e.g. suspended scaffold or relocation by crane), turn the verticals through 90° to fit them. Otherwise the ends of the verticals will not engage in a form-fit manner. (Fig. A11.12b + A11.12c)



To prevent slipping, insert a screw in an upper hole through the connector before assembly.

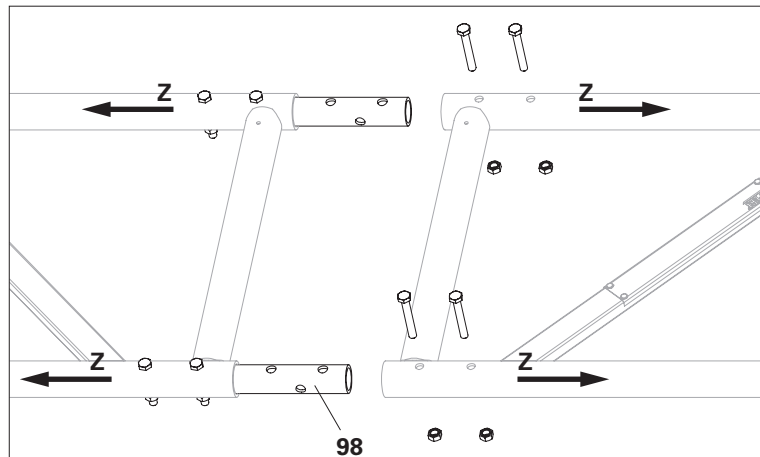

Fig. A11.12a

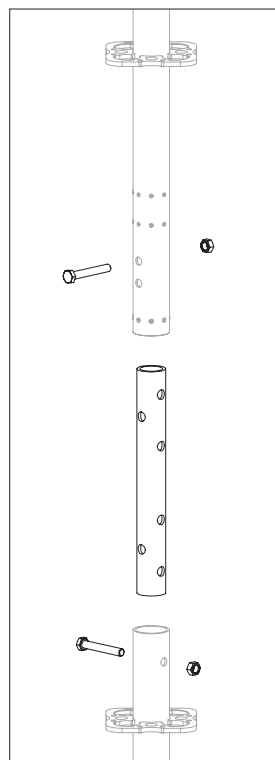

Fig. A11.12b

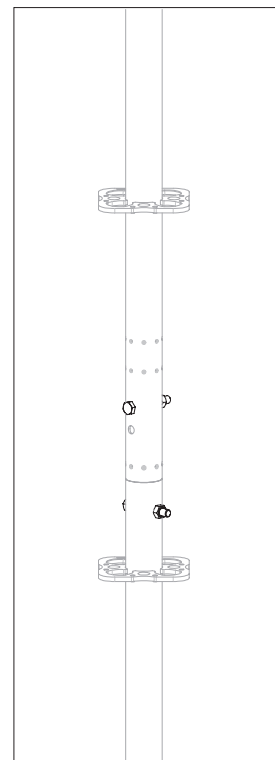

Fig. A11.12c

Application example

Loose pin for connecting tubes \varnothing 48.3, e.g. formwork girders or top standards.

Pin with Spacer Tube URE 4/42

- The pin with spacer tube enables further assembly on Top Standards EVT 96 in the system grid. The 4 cm high ring of the spacer tube extends the Top Standard EVT 96 to 100 cm
- Depending on the system and assembly sequence, unsecured drop-off edges may result. In any case, check whether PPE is required.

Assembly

1. Insert the long pin (**99.1**) of the URE 4/42 (**99**) into the Top Standard EVT 96 (**17**).
2. Attach the standard to the protruding short pin.

Application example

Temporary guardrail installation in the uppermost layer, e.g. for external console brackets.

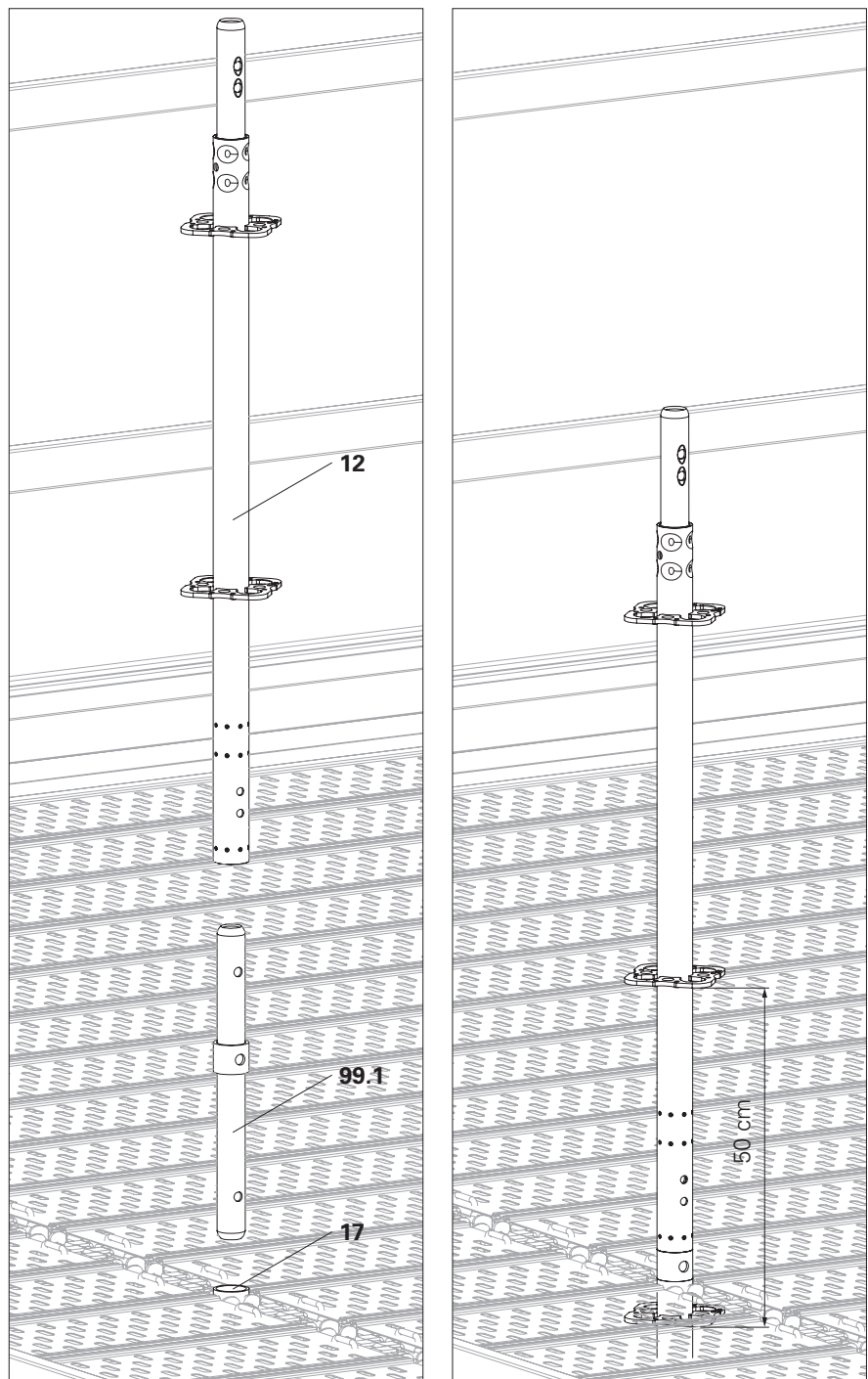

Fig. A11.13

General

Components

- 100** Eyebolt UFE
 - 101** Wall Insert UFI
 - 102** Wall Tie UWT
-

Eyebolt UFE



- The anchoring means must always be considered individually from a structural stability viewpoint. The load capacity of the mentioned eyebolts (**100**) is not sufficient for every occurring tie load!
- Check the load-bearing capacity of the anchoring base! See the Section Safety instructions, "Checking the anchoring" on page 12
- The length of the eyebolt to be used depends on the anchoring base and must be determined individually.
- Use the appropriate wall insert (**101**) for the required eyebolt, see tab. A12.01.

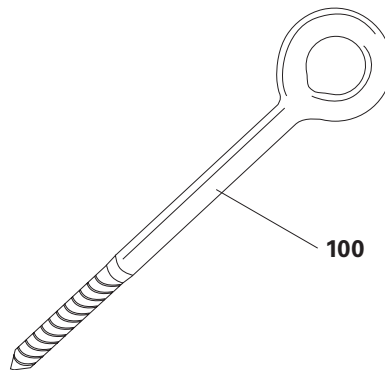

Fig. A12.01a

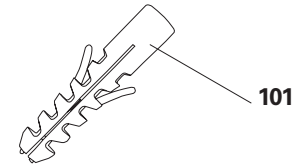

Fig. A12.01b

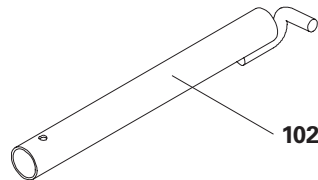

Fig. A12.01c

Eyebolt UFE	Expanding Dowel UFI
Eyebolt UFE 12/90	Expanding Dowel UFI 14/70
Eyebolt UFE 12/120	Expanding Dowel UFI 14/100
Eyebolt UFE 12/190	Expanding Dowel UFI 14/135

Tab. A12.01

Standard application

Forces acting parallel and perpendicular to the facade.

- The eyebolt (**100**) including the ring must not protrude more than 7 cm from the anchoring base. This is ensured when the eyebolt is screwed in up to the last mark in front of the ring. (Fig. A12.02)

Special application

Forces acting at perpendicular to the facade only.

- All parallel loads must be absorbed by the scaffolding system. The transmission of lateral forces is no longer possible.
- For permissible pressure forces for eyebolt see table A12.03.
- Minimum requirement for eyebolt \varnothing 12 mm, quality 4.8.



If higher compressive forces have to be dissipated, use commercially available ETICS anchorings.

Assembly

1. Hold the wall tie at the specified assembly position and check for interferences, see Section Scaffold bracket on the following page. Mark the exact installation position on the structure.
2. Install the eyebolt in the structure using suitable means, e.g. wall inserts, depending on the anchoring base. The eyebolt may protrude max. 7 cm incl. the ring.
3. Turn the ring horizontally.
→ Eyebolt is installed.

Maximum pull-out force	
Building material	Pull-out force
Concrete B25	3.9 kN
Wall brick MZ 20	1.4 kN

Always check tie points!

Tab. A12.02

Permissible compressive forces for Eyebolt UFE			
Shaft projection S^P [cm]	15	20	25
Permissible load [kN]	9.6	6.9	5.7

The values stated only apply if all parallel loads are absorbed in the scaffolding system.

See text "Special application"

Tab. A12.03

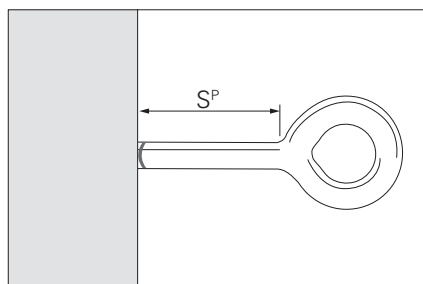

Fig. A12.02

Wall Tie UWT

- Attachments to the base scaffold, such as console brackets or supports, can affect the exact assembly position of the wall tie (**102**). Install the wall tie e.g. to the right instead of to the left of the frame column.
- Install the wall tie free of tension so that the eyebolt is not subjected to any pre-tension.

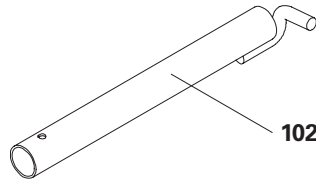

Fig. A12.03

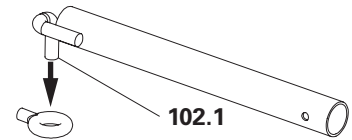

Fig. A12.03a

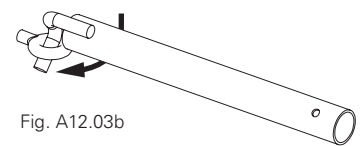

Fig. A12.03b

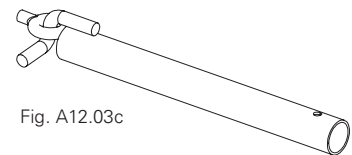
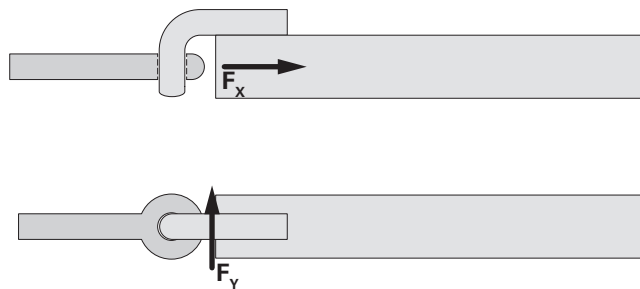

Fig. A12.03c

Assembly

1. Install the standard or system-specific coupling on the scaffold, but do not tighten it yet.
2. Turn the suspension hook (**102.1**) of the wall tie downwards and insert it into the eyebolt from above up to the stop. (Fig. A12.03a) Turn the wall tie clockwise so that the suspension hook is horizontal below the eyebolt. (Fig. A12.03b + A12.03c)
3. Close the couplings around the wall tie and, if necessary, correct the positions of the couplings on the verticals.
4. Tighten all couplings with 50 Nm.
→ Eyebolt and wall tie are installed.



Permissible forces for Wall Tie UWT	
F_x [kN]	7.91
F_y [kN]	6.25

Tab. A12.04

Multi Girder ELM 200

Components

110 Multi Girder ELM 200

The Multi Girder ELM 200 (**110**) is used for the making personnel passages or as bridging in modular scaffolds. (Fig. A13.01)

For permissible loads for Multi Girder ELM (**110**) see "PERI UP Design Tables".

Adjusting the passage width

The multi girder can be attached to:

- both end tubes on Standards UVR-2,
- an end tube on Standards UVR-2 and a UH Spigot-2 (**95**) on Top Standard UVH-2,
- two UH Spigots-2 on Top Standards UVH-2.

Use the end tubes of the multi adapter to use the full passage width.

For reduced passage widths, attach and securely wedge (**95**) one or two UH Spigots-2 (**95**) to the underside of the Multi Girder ELM (**110**) or connect with bolts M10 x 70 and nuts (**95a**). (Fig. A13.01a)

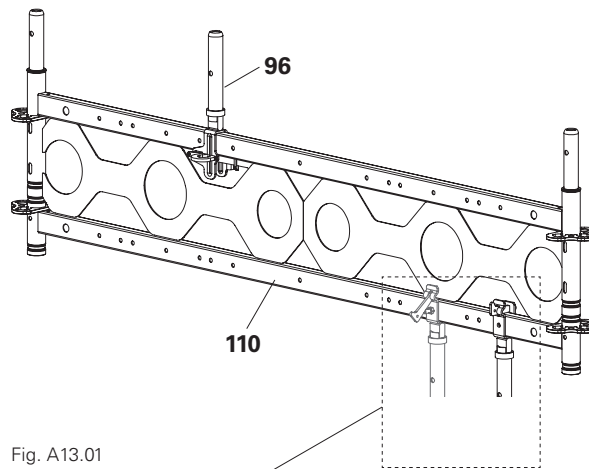

Fig. A13.01

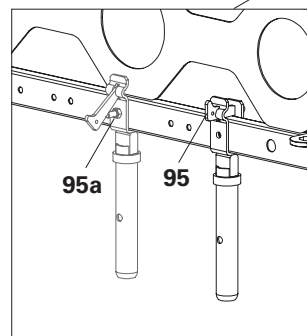

Fig. A13.01a

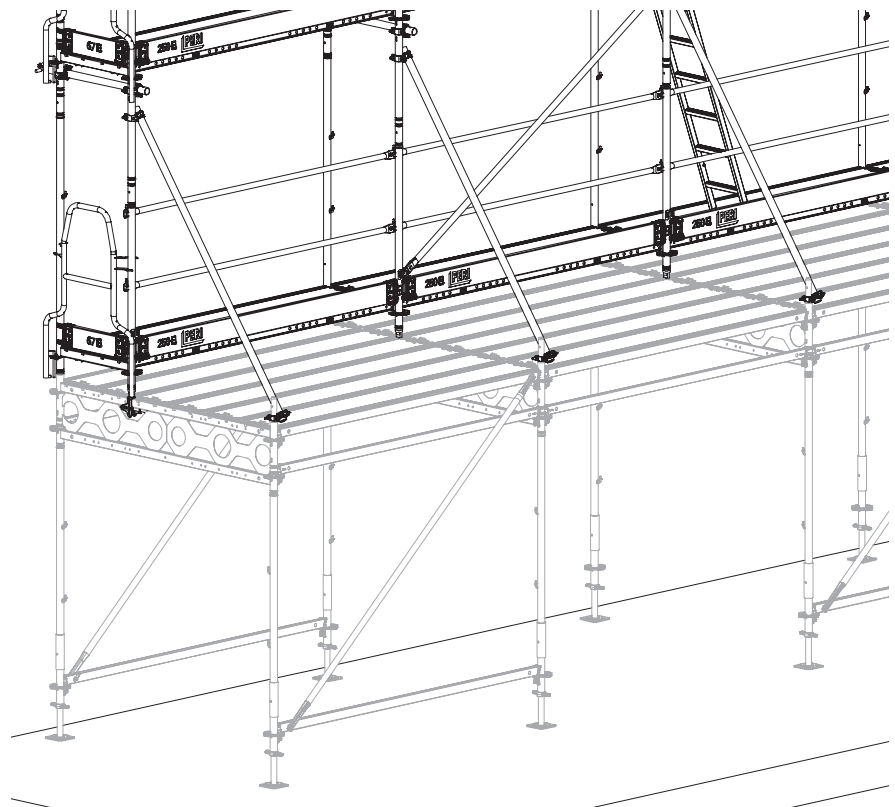

Fig. A13.01b

Positioning the scaffold assembly

The scaffold above the pavement gantry can be erected either:

- on an end tube of the multi girder and a Ledger-to-Ledger Coupler UHA-2 Half with Spigot (**96**),
- or on two Ledger-to-Ledger Couplers UHA-2 Half with Spigot

To position the scaffold assembly on the top of the Multi Girder ELM (**110**), attach the Ledger-to-Ledger Coupler UHA-2 Half with Spigot (**96**) and wedge it tight. (Fig. A13.01)

Possible combinations of pavement gantry widths and working scaffold positions are based on the system width and the construction site requirements (Fig. A13.02a + A13.02b)



- Do not load the Multi Girder ELM or UH Spigot-2!
- Scaffolds in public traffic areas are to be secured according to national legislation and regulations (e.g. traffic signs, barriers, protective components, warning lights etc.).

Combinations for system width 75 cm

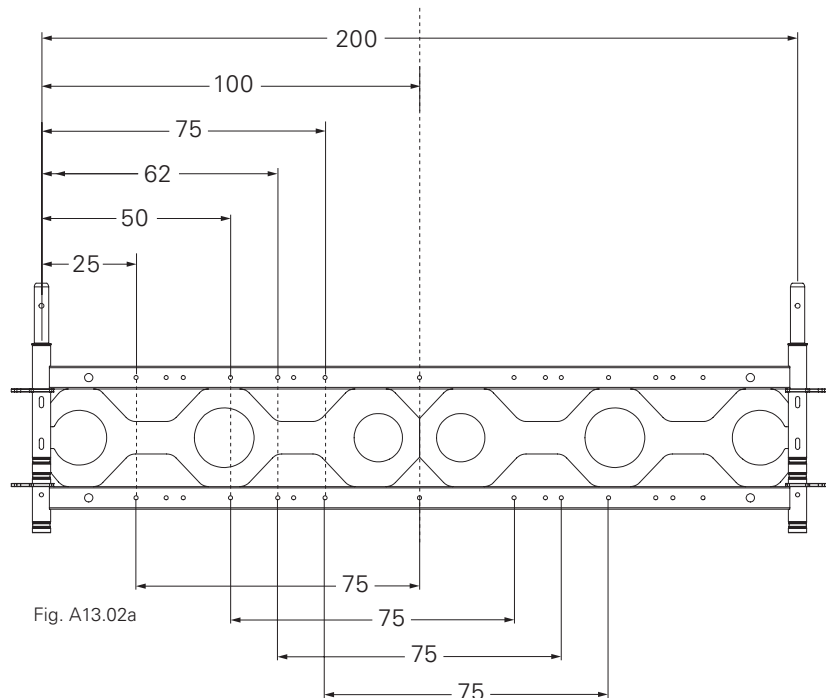

Combinations for system width 100 cm

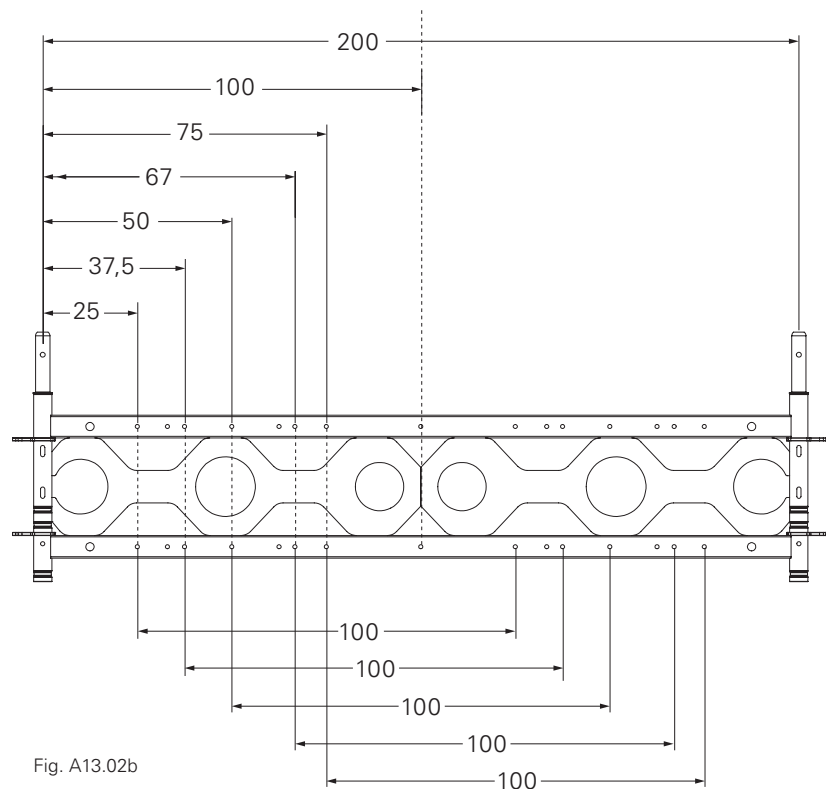

Formwork Girder ULA/ULS

For permissible loads,
see "PERI UP Design Tables"

Components

- 111** Formwork Girder ULA (aluminium)
- 112** Formwork Girder ULS (steel)

Assembly

Tightly bolt the formwork girder to the top chord (**111.1**) and bottom chord (**111.2**) with the standard coupler (**87**) on the standard. Tighten the couplings with 50 Nm. (Fig. A13.02)

Application examples

Facade scaffolds, birdcage scaffolds

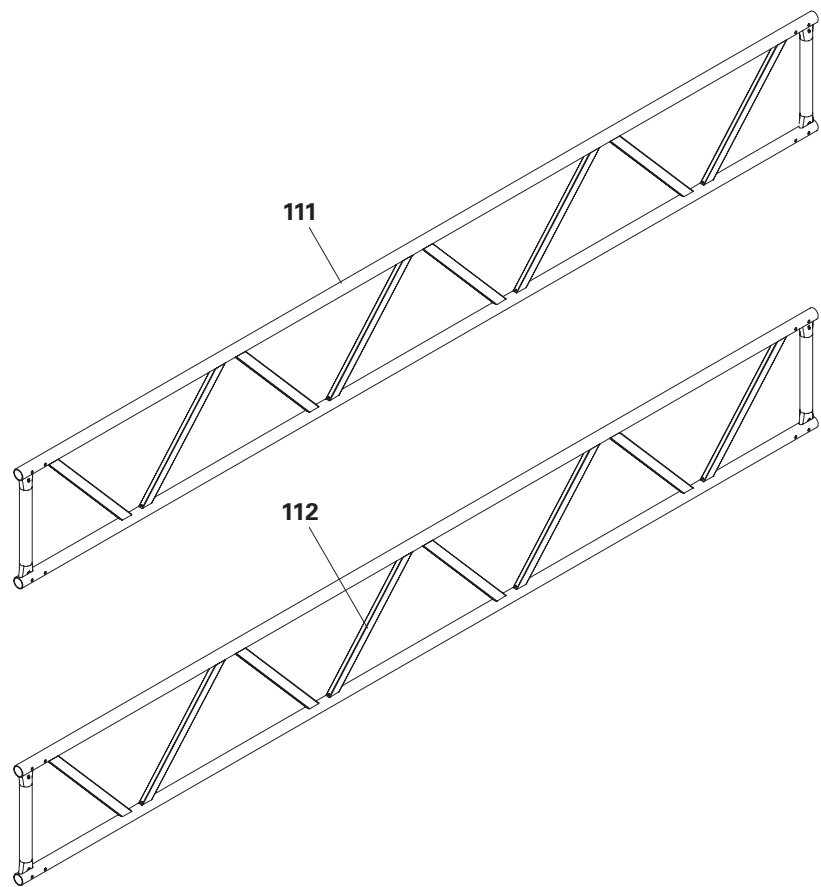

Fig. A13.01

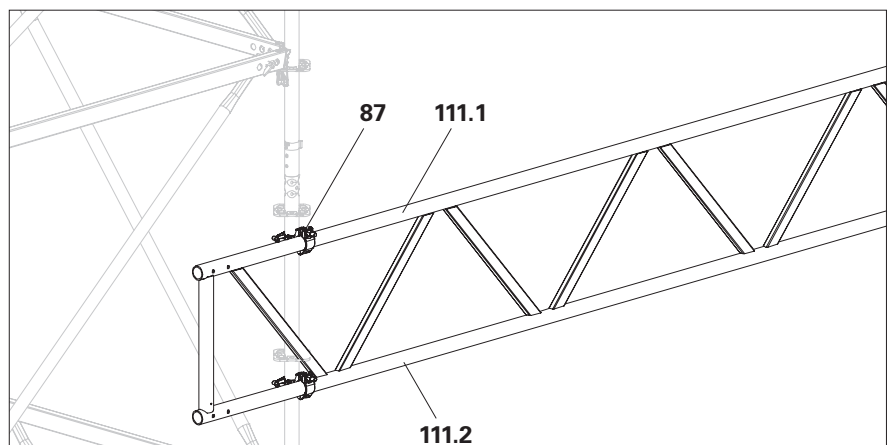

Fig. A13.02

Formwork Girder ULS Flex

Modular system for steel formwork girders.

With the Modular System ULS Flex, large-area bridging in birdcage scaffolding can be achieved.

For this purpose, several formwork girders are connected and braced with horizontal ledgers and braces.

For permissible loads and required bracing, see PI Sheet 550



Warning

When installing the formwork girders, situations with a fall hazard may occur! A fall can cause serious to fatal injuries.
 ⇒ Use guardrails according to project-specific risk analysis.

Components

- 113a** Intermediate Element ULS 100 Flex
- 113b** Intermediate Element ULS 125 Flex
- 113c** Intermediate Element ULS 150 Flex
- 114** End Element ULS 50 Flex
- 115** Connector ULS Flex

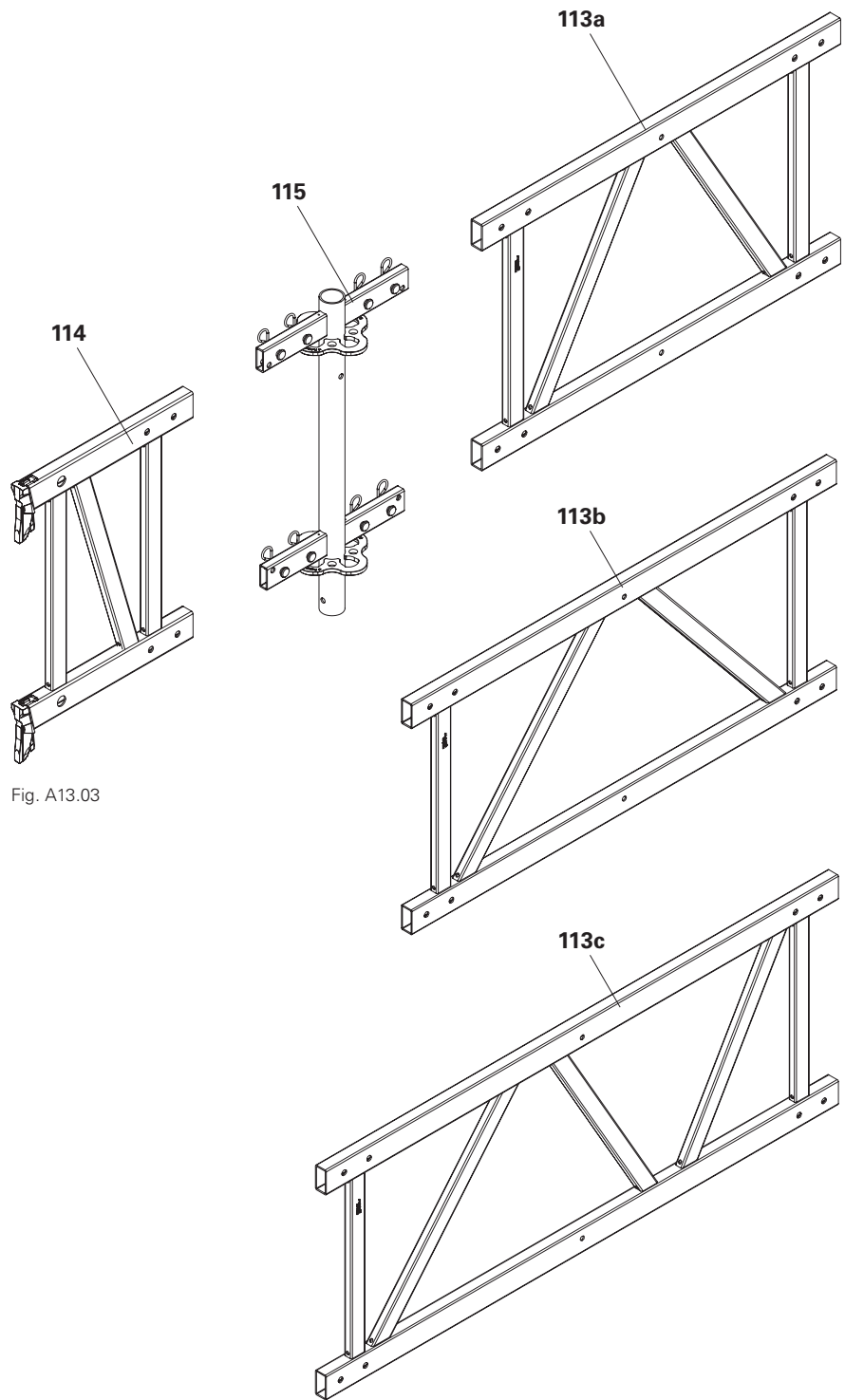

Fig. A13.03

Application examples

Suitable for material transport in lifts or other confined situations, e.g. through manholes in production plants, stairwells.

Pre-assemble formwork girder

1. Install Connector ULS Flex (**115**) to an End Element ULS 50 Flex. To do this, insert connectors (**115.1**) of the connector into the upper and lower chords (**114.1**) of the end element. Connect connector and end element with the 4 supplied collar pins $\varnothing 12 \times 44$ (**115.2**) and cotter pin 4/1 (**115.3**). (Fig. A13.04a + A13.04b)
2. Install an Intermediate Element ULS Flex (**113**) on the pre-assembled connector (**115**) of the end element in the same manner. (Fig. A13.04c)
3. Depending on the project-specific planning, mount further intermediate elements with connectors in the same manner.
4. Install the second end element with Connector ULS in the same manner.
→ Formwork girder is pre-assembled. (Fig. A13.04d)

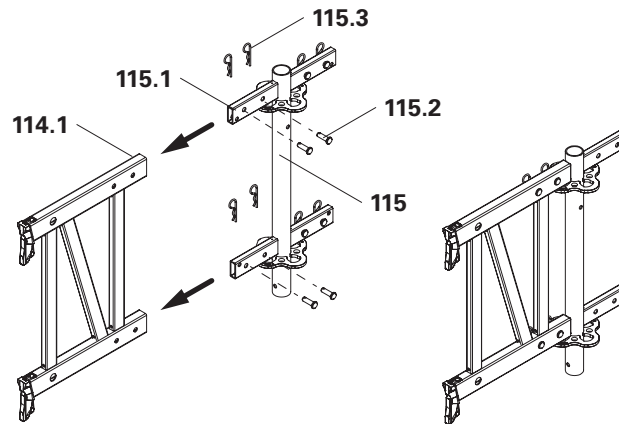

Fig. A13.04a

Fig. A13.04b



Additional formwork girders can be mounted on the Connector ULS Flex at an angle of 90°, (project-specific verification required.)

Fitting the formwork girders

1. Attach the formwork girder securely to the crane or other lifting device and bring it into the installation position.
2. Insert all wedges of the end elements into the rosettes of the standards and hammer the wedges in tight.

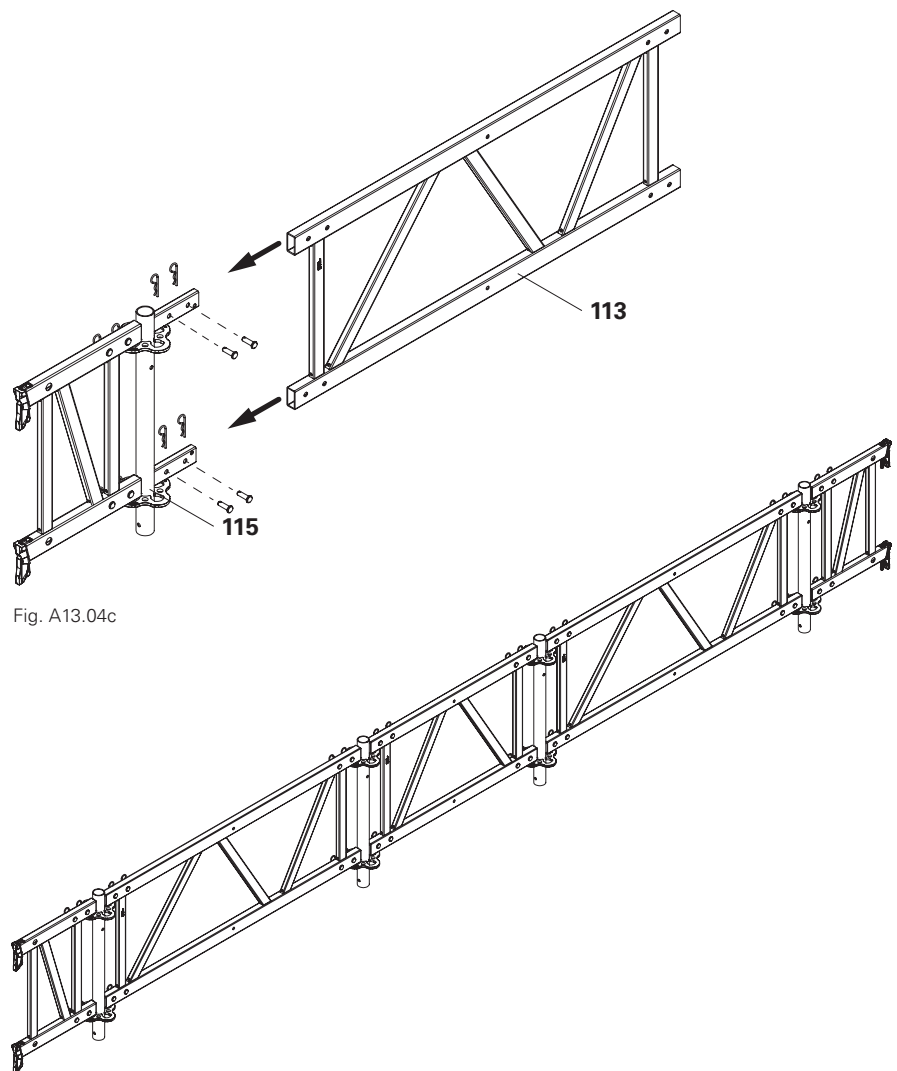

Fig. A13.04c

Fig. A13.04d

Alternative

Create an auxiliary scaffold in the bridging area and assemble the formwork girders directly at the assembly position.

Brace formwork girders.

For the number and position of stiffening components, see PI Sheet 550

Structures with formwork girders must always be verified for structural stability.

The formwork girder with the largest influence width is the decisive factor for the load-bearing capacity.

Assembly

1. Connect the formwork girders with Horizontal Ledgers UH Plus (**14**).
Secure the wedges.
2. Install Ledger Braces UBL (**23**).
3. Install Horizontal Braces UBH Flex (**20**).
(Fig. A13.05 + A13.05a)

Example

Formwork girder with 5.0 m span.
For further examples, see PI Sheet 550.

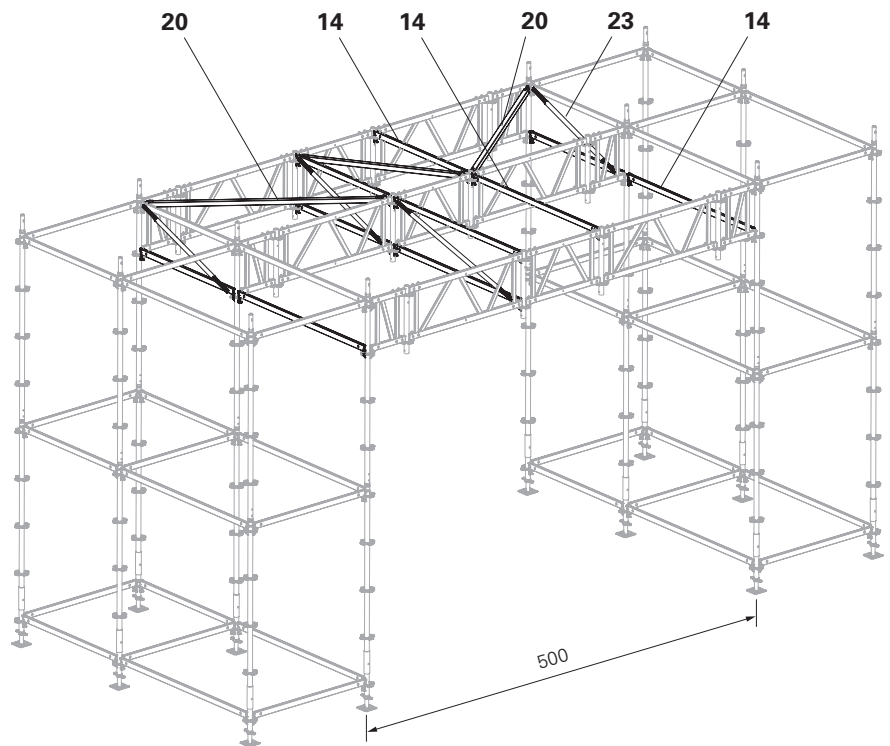

Fig. A13.05

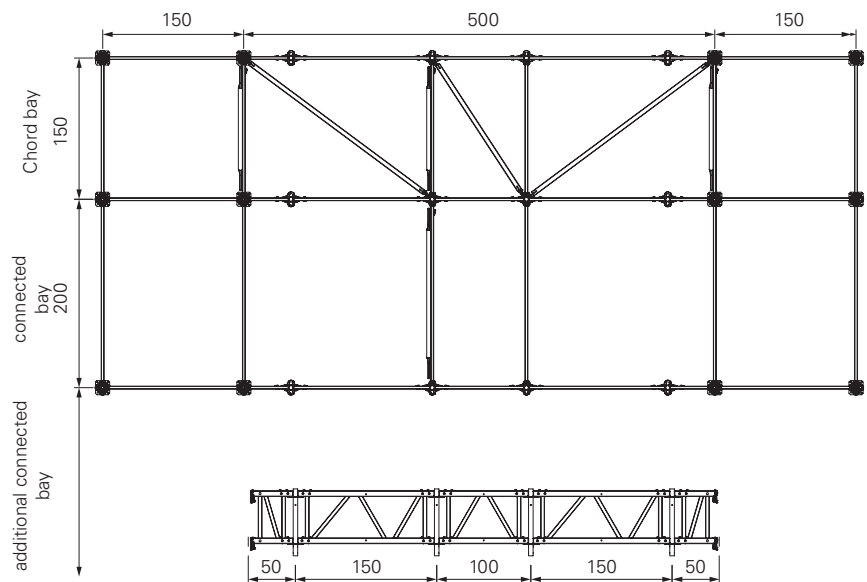

Fig. A13.05a

LGS Keder Track URK LGS Keder Connector URV

The LGS Keder Track URK (**122**) is suitable for tarpaulins with 13 mm keder.

Installing on scaffolding tubes with \varnothing 48 mm is done with LGS Keder Connector URV (**121**).



- Fit the keder connections a maximum of 1.50 m apart.
- Fit at least 2 keder connections for each keder track.
- The keder track connector is suitable for pipes with \varnothing 48 mm.
- Verify snow and wind loads on a project-specific basis.

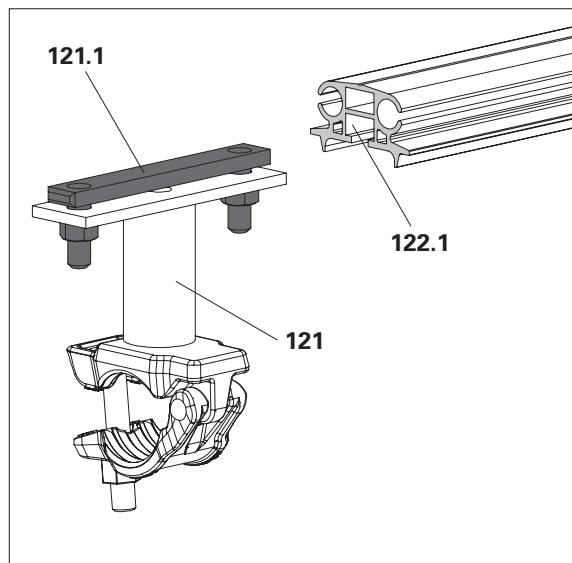

Fig. A14.01

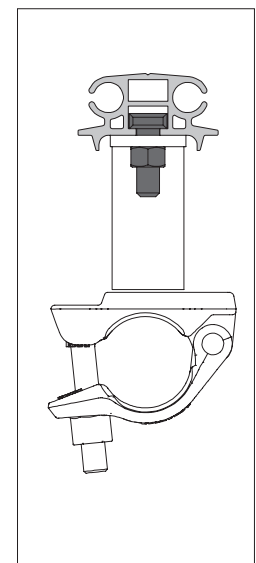

Fig. A14.01a

Install the keder track connector overlapping at the joint of the keder tracks.

Assembly

1. Cut the LGS Keder Track URK (**122**) to the required length and remove the burr.
 2. Slide the terminal strip (**121.1**) on the Keder Connector URV (**121**) into the T-groove (**122.1**) of the Keder Track URK and bolt it into place.
 3. Install pre-assembled keder tracks with the coupling side (**121.2**) of the keder connector on the respective vertical. (Fig. A14.02) For changes of direction, leave some space between the tracks at the joint for easier threading of the tarpaulin.
- The keder track is now installed.

Application example

Protection of work areas as a wall or as a roof.

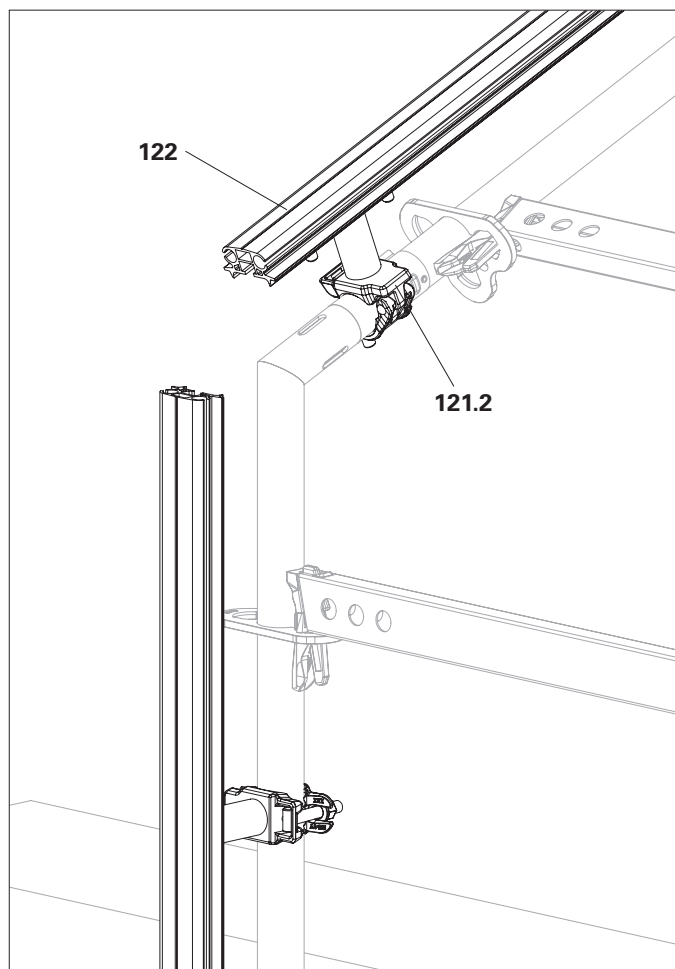

Fig. A14.02

Multi Brace EWB

On structures that do not allow anchoring, Multi Braces EWB can be installed as scaffold support.

A multi brace consists of:

- Outer tube Ø 60 mm (**135.1**) with fixed swivel coupling on both sides. (**135.3 + 135.4**)
- Inner tube Ø 48 mm (**135.2**). (Fig. A15.01)



- Maximum extension length 5.60 m. The second hole (**135.6**) in the inner tube must not be visible and must always be completely covered by the outer tube. (Fig. A15.01)
- Tighten couplings using 50 Nm.
- Attach scaffolding support on each frame column progressively in line with basic scaffold assembly. Support angle $\alpha \leq 60^\circ$.
- The force application must be close to the horizontal ledger. (Fig. A15.01a)

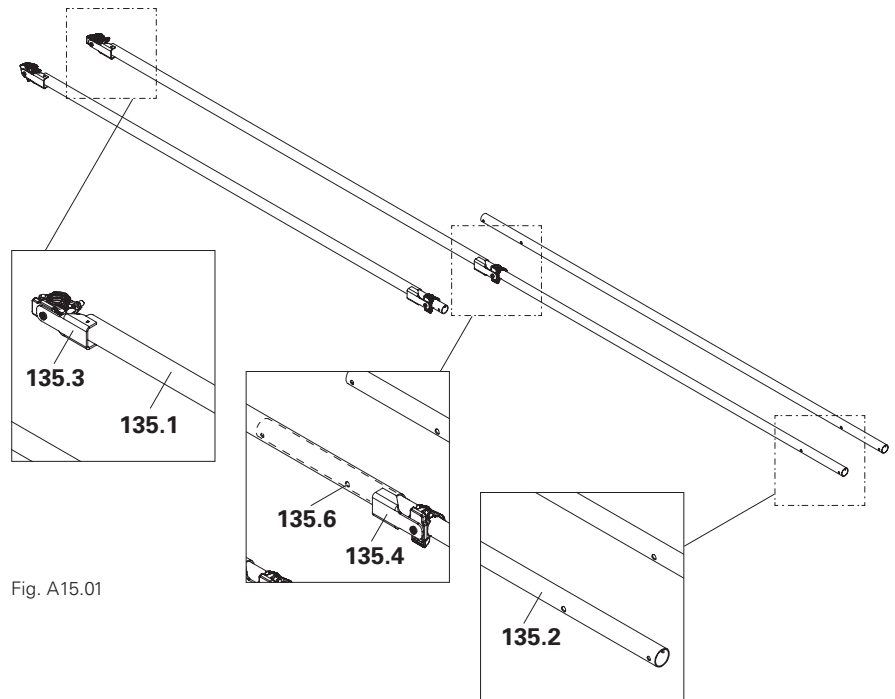

Fig. A15.01

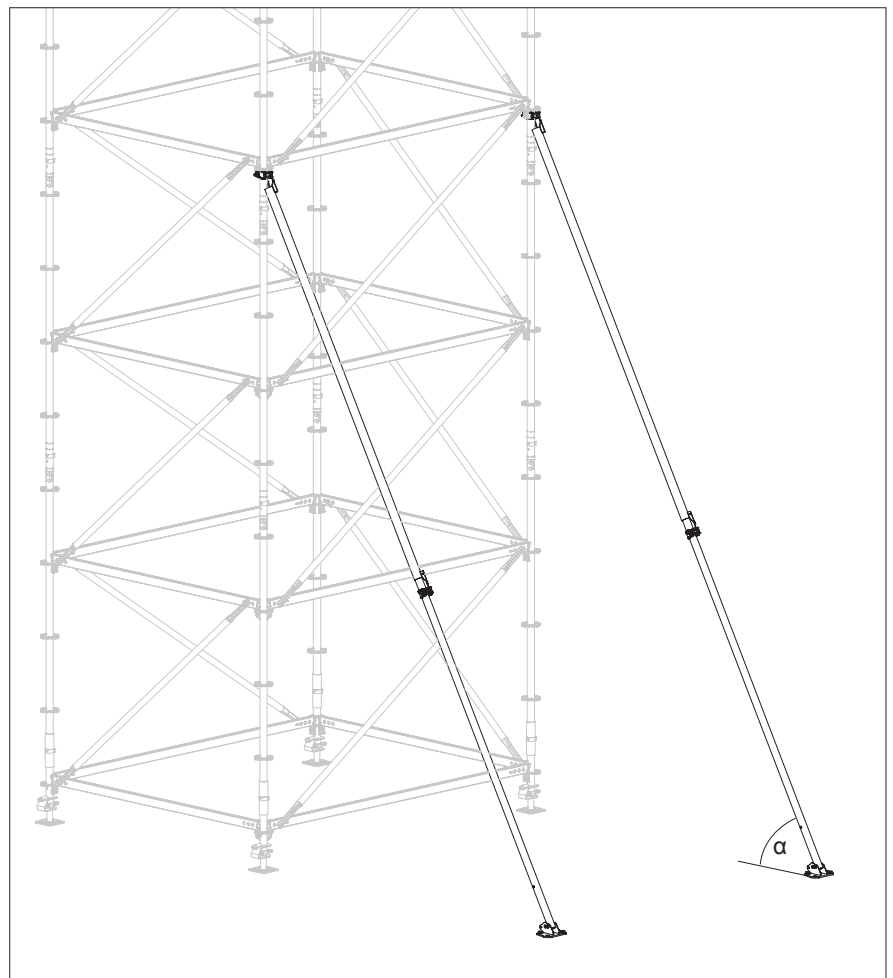

Fig. A15.01a

Base Plate EWB

Fix the Base Plate (**136**) to the substrate using 2 tie bolts (**137**) inserted through the small holes (**136.1**).

Alternatively, fix the base plate to the substrate by means of 2 pegs through the large holes (**136.2**).

Base plate is suitable for standard ground nails up to $d = 25 \text{ mm}$. The hole (**136.2**) of the base plate has a diameter of 28 mm.

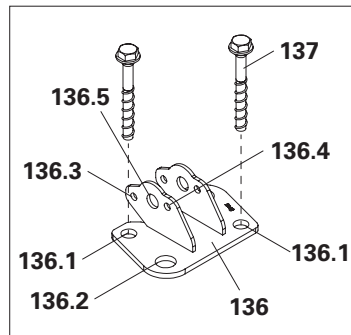

Fig. A15.02

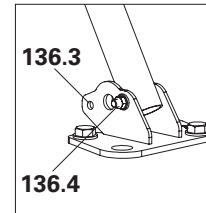

Fig. A15.03a

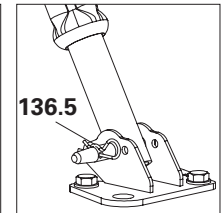

Fig. A15.03b

Install the inner tube of the multi brace with bolt and nut to the hole (**136.4**). Install a multi brace as a kicker brace at the hole (**136.3**).

(Fig. A15.02 + A15.03a)

Instead of the Multi Brace EWB, one Push-Pull Prop RS can be installed on the middle hole (**136.5**) as scaffolding support.

(Fig. A15.03b)

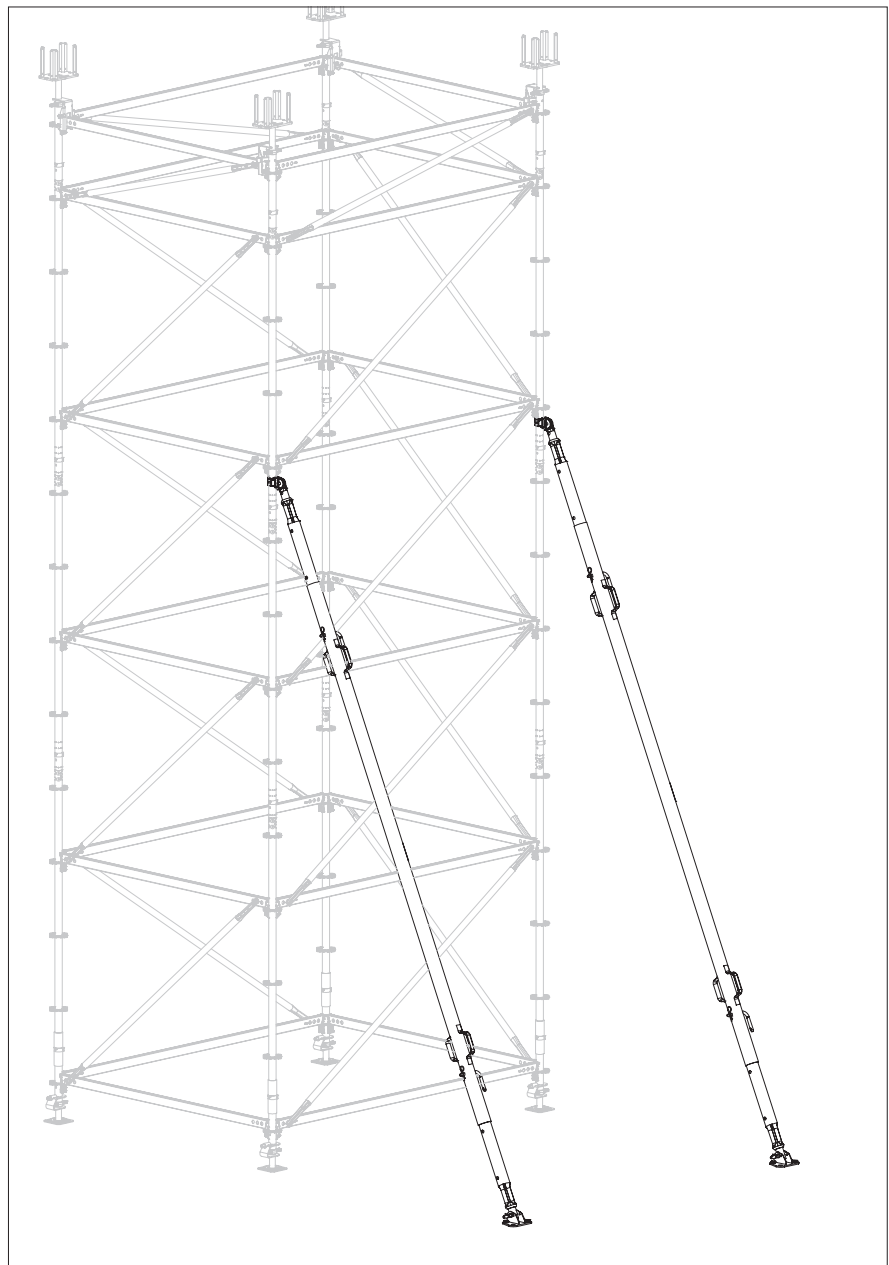

Fig. A15.02

Support up to 4.80 m height

Maximum permissible forces at maximum extension of 5.57 m:

(Fig. A15.04a):

Tension: 6.00 kN

Compression: 3.73 kN

Assembly

1. Secure the multi brace on the basic scaffold at the top with an outer tube (**135.1**).
2. From a safe work location, fit the upper coupling (**135.3**) to the standard (**12**). Push the coupling as close as possible to the rosette and tighten. (Fig. A15.04a)
3. Loosen the bottom coupling (**135.4**) and extend the multi brace until the required support angle of $\alpha \leq 60^\circ$ has been reached. Tighten the bottom coupling. (Fig. A15.04b)
4. Fit the inner tube (**135.2**) onto the rear hole (**136.4**) of the base plate by means of bolts (**137**) and nuts (**138**). (Fig. A15.04c)
5. Fix Base Plate EWB (**136**) to the substrate.
6. Label the multi brace as an obstacle.
→ The multi brace is now installed (Fig. A15.04)

Components

- 12** Standard UVR-2
- 134** Scaffold support*
- 135** Multi Brace EWB
- 136** Base Plate EWB
- 137** Bolt M10 x 80-8.8
- 138** Nut EN 1661 M10-8
- 139** Tie Bolt PERI 14/20 x 130

*The scaffold support and the inner tube of the multi brace are identical in terms of their construction.

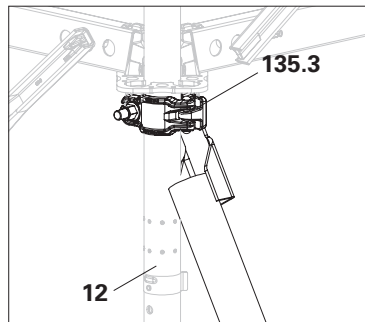

Fig. A15.04a.

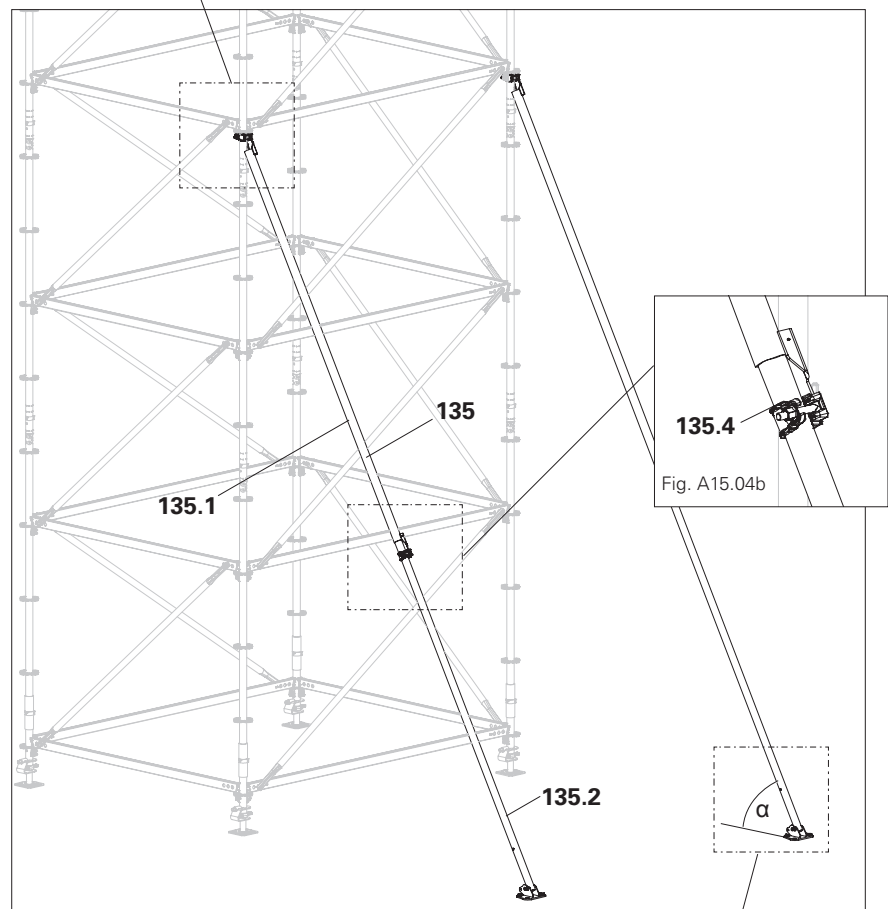

Fig. A15.04.

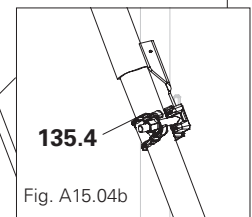

Fig. A15.04b

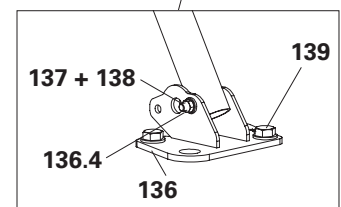

Fig. A15.04c

Support up to 7.10 m height

To extend the multi brace, insert another inner tube into the top side of the outer tube.

Maximum permissible forces at maximum extension of 8.20 m:

(Fig. A15.05a):

Tension 6.00 kN

Pressure 1.31 kN

Assembly

1. Extend the Multi Brace EWB with a scaffold support (**134**) or a further inner tube (**135.5**).
2. Insert upper inner tube (**135.5**) up to above the second hole in the outer pipe and tighten the coupling.
3. Secure the multi brace on the basic scaffold.
4. From a safe work location, mount the inner tube to the standard (**12**) with a swivel coupling (**88**). Push the coupling as close as possible to the rosette and tighten. (Fig. A15.05a)
5. Loosen the bottom coupling and extend the multi brace until the required support angle of $\alpha \leq 60^\circ$ has been reached. Tighten the bottom coupling.
6. Fit the inner tube (**135.2**) onto the rear hole (**136.4**) of the base plate by means of bolts (**137**) and nuts (**138**). (Fig. A15.05c)
7. Fix Base Plate EWB (**136**) to the substrate.
8. Label the multi brace as an obstacle.
→ The multi brace is now installed (Fig. A15.05)

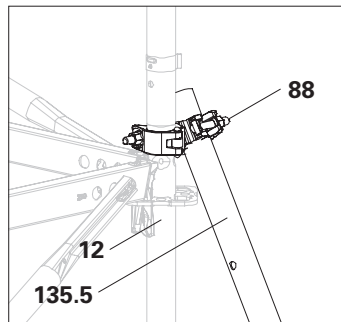

Fig. A15.05a

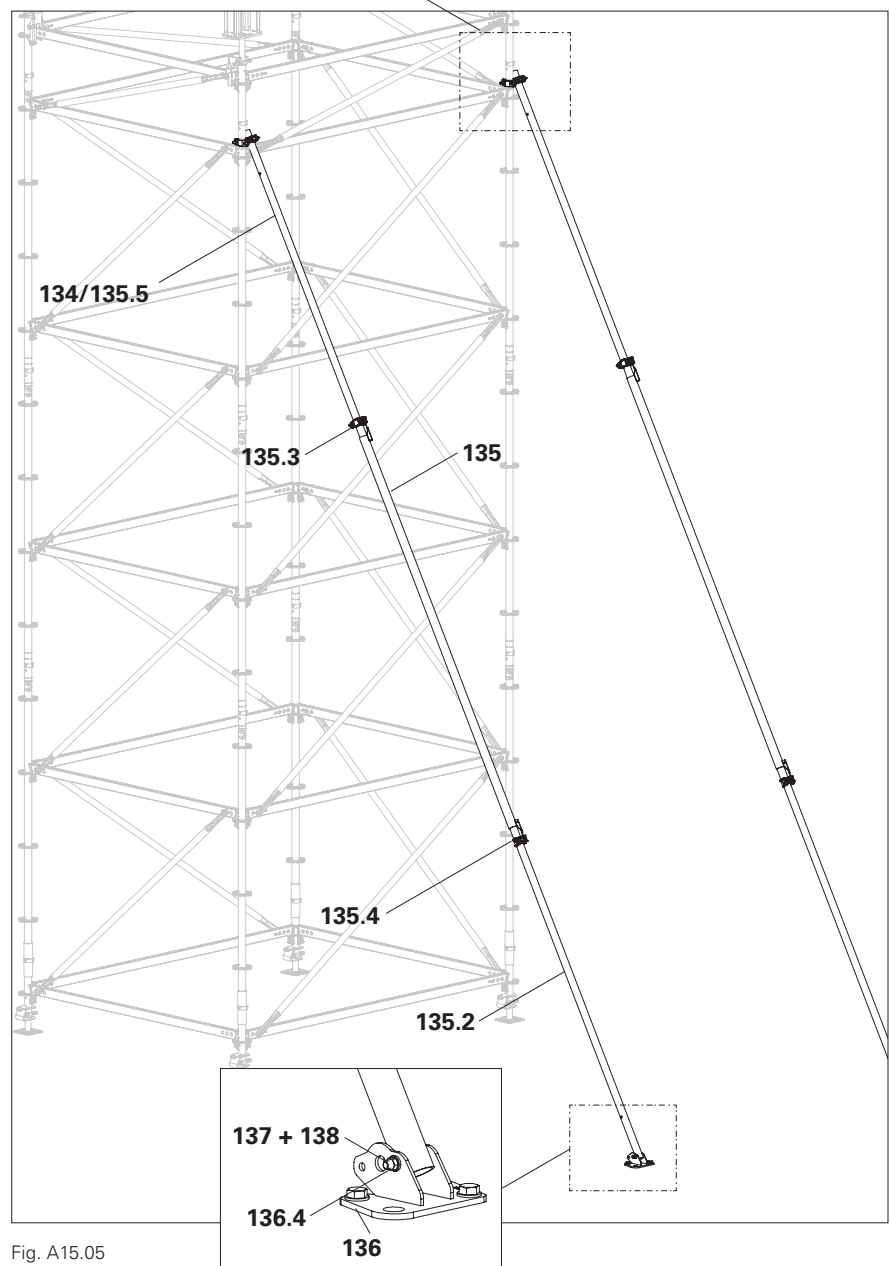

Fig. A15.05

Fig. A15.05c

Bracing

At right angles to the basic scaffold

In special cases, it may be necessary to reinforce the multi brace by means of a ledger, e.g. if the base plate cannot be sufficiently secured to prevent horizontal kicker brace.



- Separate static proof is required!
- The vertical load-bearing capacity of the substrate under the base plate must be guaranteed in any case!

Assembly

1. Fit an inner tube (**135.2**) onto the front hole (**136.3**) of the base plate (**136**) by means of bolts (**137**) and nuts (**138**). (Fig. A15.06b).
 - Alternatively, install a scaffolding tube with swivel coupling on the multi brace.
 2. Install the inner tube or scaffolding tube on the standard (**12**) with a swivel coupling (**49**). Tighten the swivel coupling. (Fig. A15.06a)
 3. Label horizontal bracing as an obstacle.
- The bracing is now installed.
(Fig. A15.06)

Required length of the scaffolding tube:
for support up to 4.80 m
approx. 2.50 m,
for support up to 7.10 m
approx. 4.00 m.

Components

- 12** Standard UVR-2
- 87** Standard coupling 48/48
- 88** Swivel coupling 48/48
- 135** Multi Brace EWB
- 136** Base Plate EWB
- 137** Bolt M10 x 80-8.8
- 138** Nut EN 1661 M10-8

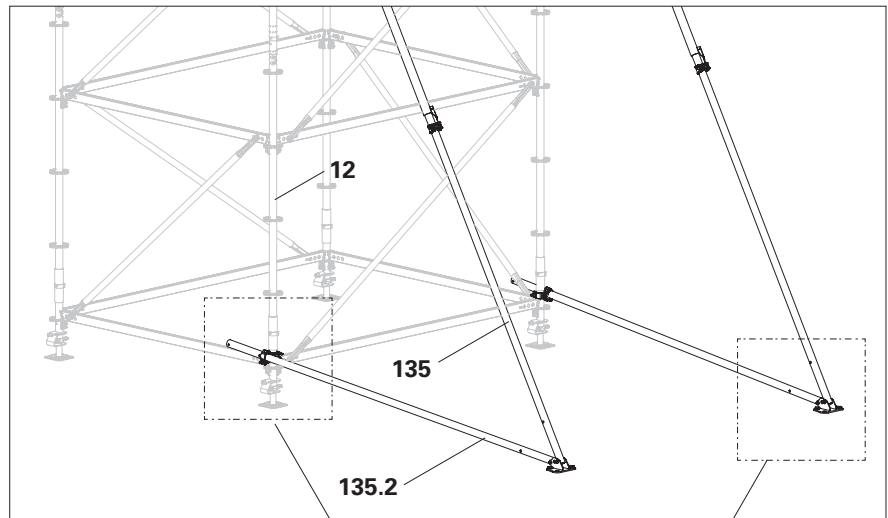

Fig. A15.06

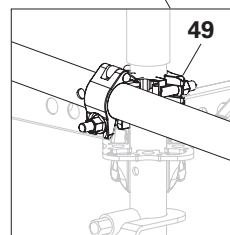

Fig. A15.06a

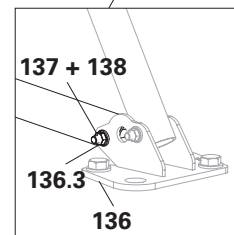

Fig. A15.06b

Horizontal and vertical bracing

If required according to the structural stability calculations, the multi-support must be braced against vertical and horizontal deflection.



- Separate static proof is required!
- The vertical load-bearing capacity of the substrate under the base plate must be guaranteed in any case!

Assembly

1. Vertically reinforce the multi brace (135) with an outer tube (135.1). Fit the outer tube to the standard (12) (Fig. A15.07b) and to the inner tube (135.2), close to the outer tube. The assembly position has an impact on the support angle.
2. For 3 m long bays, horizontally reinforce each multi brace with an outer tube.
For bay lengths ≤ 2.5 m, horizontally reinforce each multi brace with a scaffolding tube (145) and standard couplers (87). (Fig. A15.07a)
3. Label horizontal bracing as an obstacle.
→ The bracing is now installed. (Fig. A15.07)

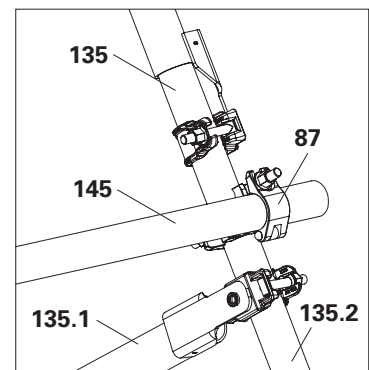

Fig. A15.07a

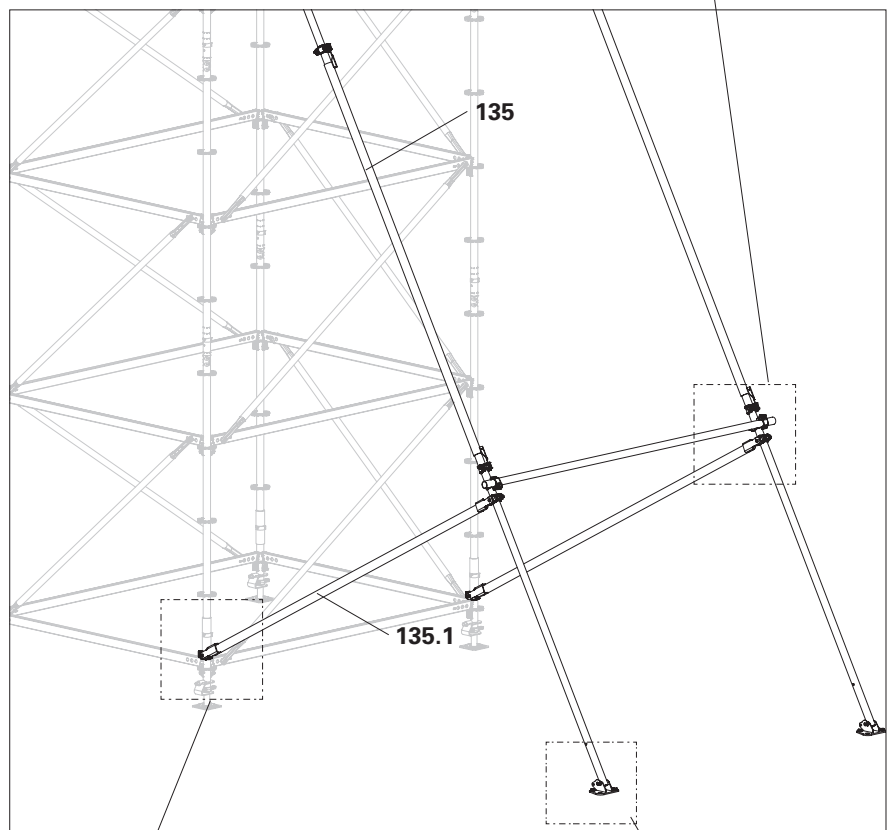

Fig. A15.07

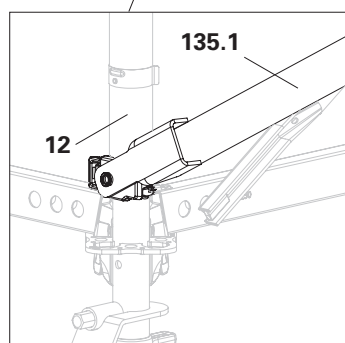

Fig. A15.07b

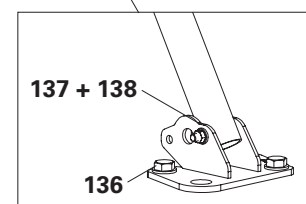

Fig. A15.07c

Push-Pull Props RS

As an alternative to the multi brace, the scaffolding can be supported with Push-Pull Props RS.

Assembly

1. From a safe position, fit the Brace Connector HDR-2 (**146**) to the standard (**12**). Push the coupling as close as possible to the rosette and tighten.
 2. Install Push-Pull Prop RS (**147**) on Brace Connector HDR-2. (Fig. A15.08a)
 3. Spindle out the push-pull prop until the required support angle of $\alpha \leq 60^\circ$ has been reached.
 4. Fix the push-pull prop in the large hole of the base plate with bolts (**148**) and cotter pins (**149**). (Fig. A15.08b)
 5. Fix Base Plate EWB (**136**) to the substrate.
 6. Label the push-pull prop as an obstacle.
- The push-pull prop is now installed. (Fig. A15.08)



Observe the permissible loads of the push-pull props and the brace connector.

Components

- | | |
|------------|----------------------------------|
| 12 | Standard |
| 136 | Base Plate EWB |
| 146 | Brace Connector HDR-2 |
| 147 | Push-Pull Prop RS 650 |
| 148 | Bolt $\varnothing 20 \times 140$ |
| 149 | Cotter pin 4/1 |

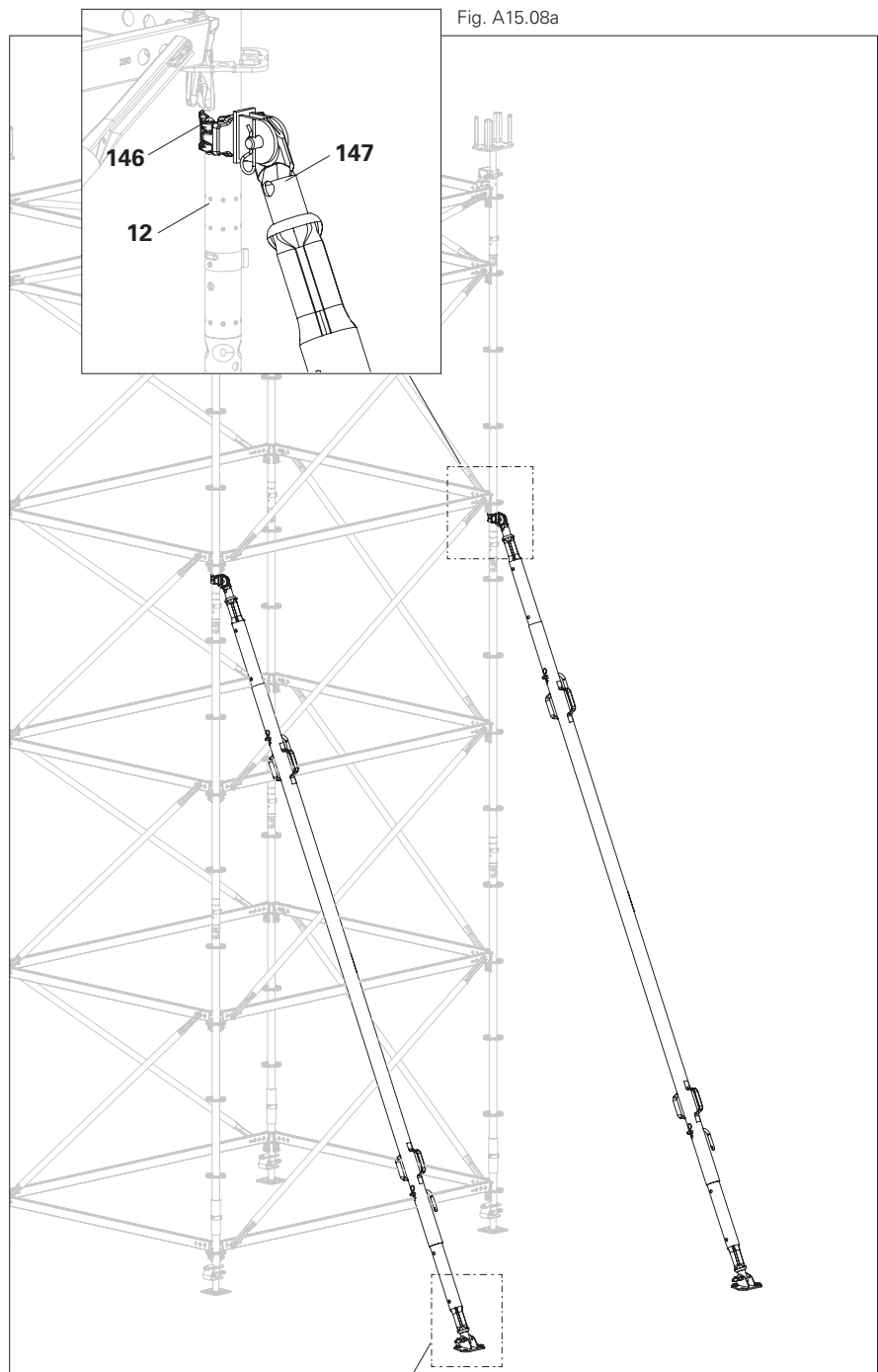

Fig. A15.08a

Fig. A15.08

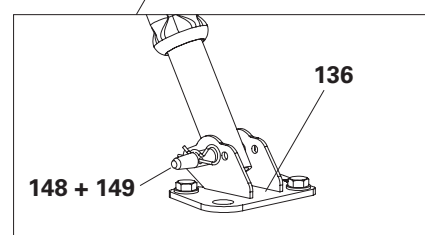

Fig. A15.08b

General

All polycover components

- make use of signal colours to indicate hazard areas,
- lower the risk of injury in the event of impact,
- reduce fouling.



Note

If handled incorrectly, polycover components may break.

- ⇒ Do not use a hammer when working with polycover components.
- ⇒ At temperatures below 0 °C, preheat polycover components for assembly.

Poly Cover Tubes UPC-T

For closing tube ends with $d = 48.3 \text{ mm}$. (Fig. A16.01)

1. Push the Poly Cover Tube UPC-T (120) onto the end of a tube with $d = 48.3 \text{ mm}$. (Fig. A16.01a)
- The poly cover is mounted.



Fig. A16.01

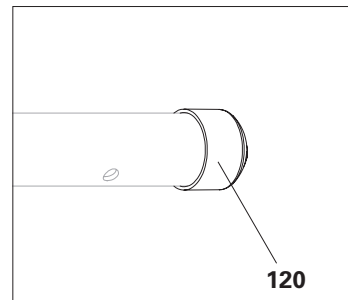

Fig. A16.01a

Poly Cover Rosette UPC-R

For protection around ledger-free rosettes. (Fig. A16.02)

1. Position the Poly Cover Rosette UPC-R (121) with one half on the rosette.
 2. Close the second half.
 - The clip fastener engages.
 - The poly cover is mounted.
- (Fig. A16.02a)

- The poly cover rosette can be additionally secured with cable ties.

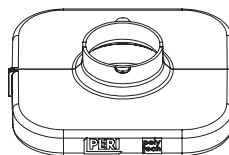

Fig. A16.02

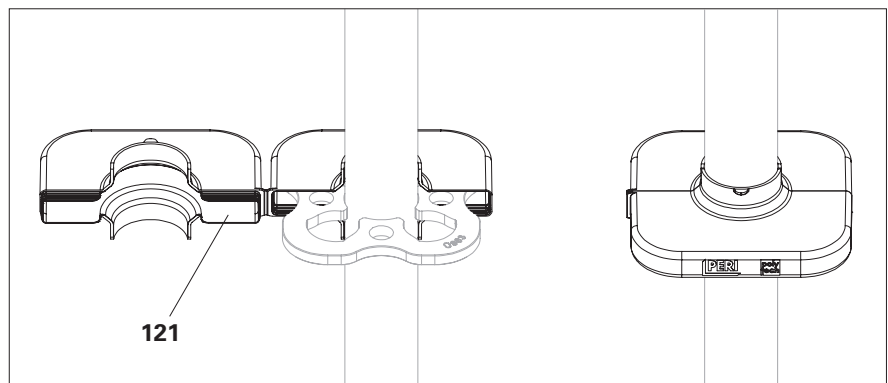

Fig. 16.02a

Poly Cover Couplings UPC-C

For protection around a rosette with ledgers installed or around threaded pipe/coupling connections.
(Fig. A16.03)

Assembly

1. Clip the Poly Cover Couplings UPC-C (**122**) onto the vertical $d = 48.3$ mm.
 2. For ledgers arranged around a 90° corner: fit Poly Cover UPC-C (**122 + 122a**) in an overlapping manner.
(Fig. A16.03a)
 3. If ledgers are arranged longitudinally: fit Poly Cover UPC-C on both sides.
(Fig. A16.03b)
 4. In case of crossing tubes, mount 2x poly covers UPC-C overlapping on one or both tubes.
(Fig. A16.03c + A16.03d)
- The poly cover is mounted.

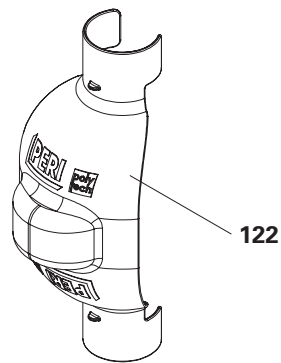

Fig. A16.03



Use cable ties to provide the poly cover couplings with extra reinforcement.

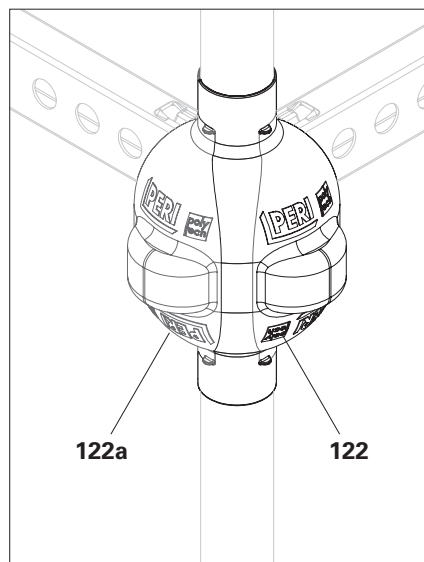

Fig. A16.03a

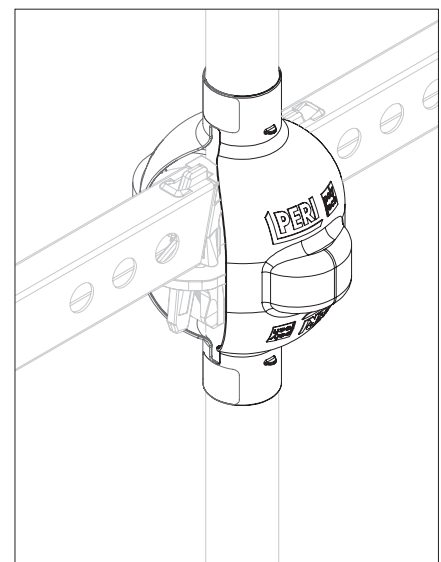

Fig. A16.03b

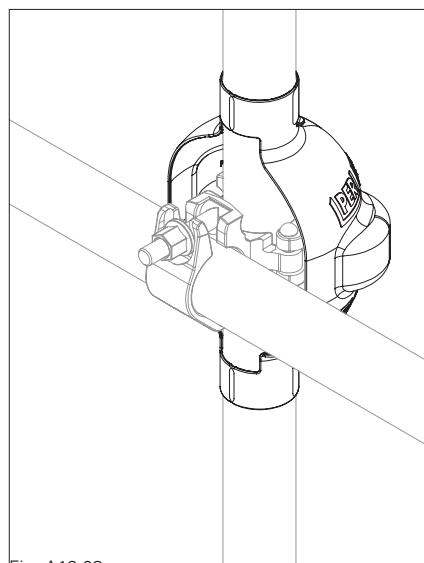

Fig. A16.03c

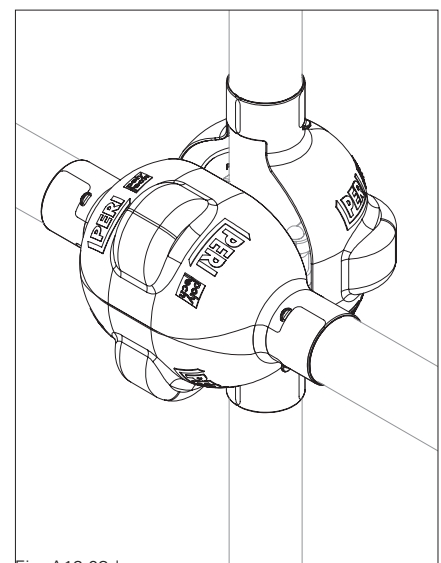

Fig. A16.03d

Spindle Lining UES

Spindle Lining UES serves to protect the substrate.

If additional reflectors (**123.1**) are installed, this improves visibility. (Fig. A16.04)

The component can transfer compression forces of up to 50 kN.

Assembly

1. Place the spindle lining (**123**) on a flat and load-bearing substrate
2. Position the spindle centrally
→ The spindle lining is installed. (Fig. A16.04a)

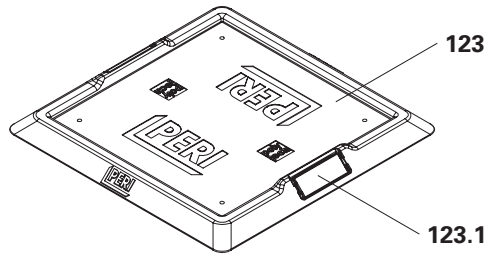

Fig. A16.04



Static proof for transferring forces into the substrate is to be carried out separately.

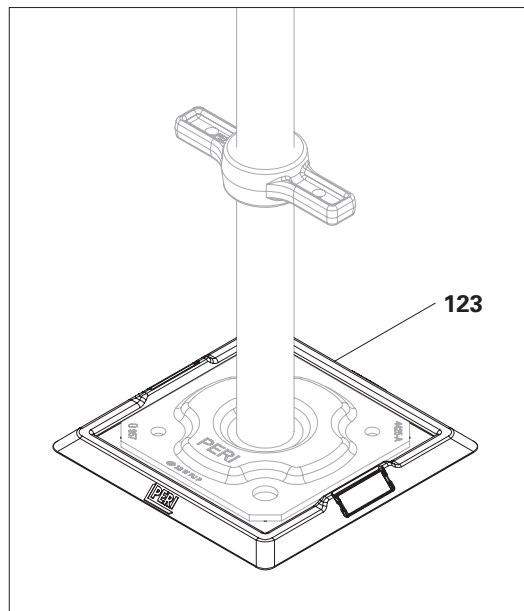

Fig. A16.04a

Article no. Weight kg

100244 1.200

Base Plate UJP

Without height adjustment.

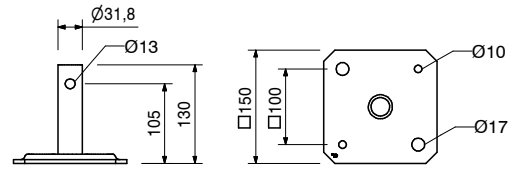
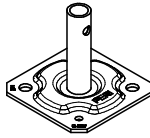

116762 2.830

Base Spindle UJB 38-36/17

Note

With captive quick jack nut.

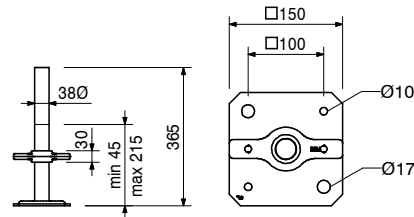
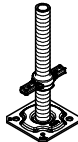

100863 1.020

Accessories

Spindle Locking UJS

100411 3.390

Base Spindle UJB 38-50/30

Note

With captive red quick jack nut.

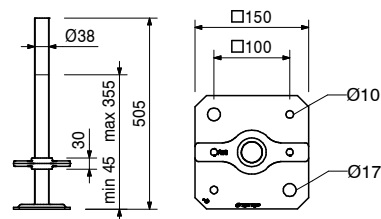

100863 1.020

Accessories

Spindle Locking UJS

100242 4.570

Base Spindle UJB 38-80/55

Note

With captive yellow quick jack nut.

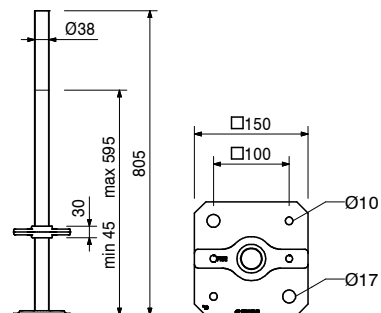
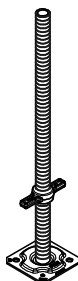

100863 1.020

Accessories

Spindle Locking UJS

Article no. Weight kg

019780 5.250

Base Spindle TR 38-70/50

For higher loaded shoring scaffolds.

Note

With captive silver quick jack nut.

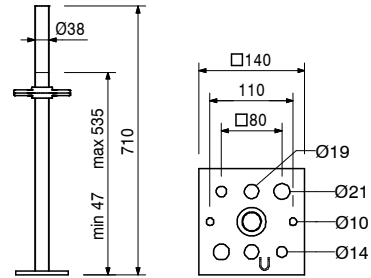
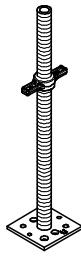

Accessories

100863 1.020

Spindle Locking UJS

100159 5.130

Pivoting Base Spindle UJS 38-80/50

Note

With captive yellow quick jack nut.

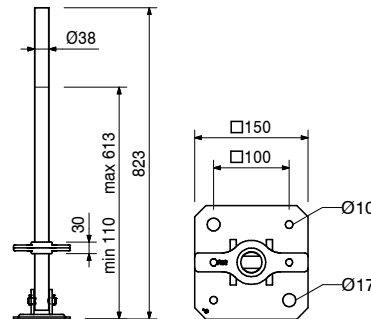
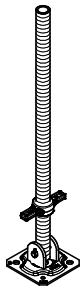

Accessories

100863 1.020

Spindle Locking UJS

123941 12.500

Castor UEW 30 with spindle

As a non-steerable and unbraked castor for mobile scaffolds. Wheel body white.

Technical data

Permissible load up to 30 kN depending on spindle extension and bracing.

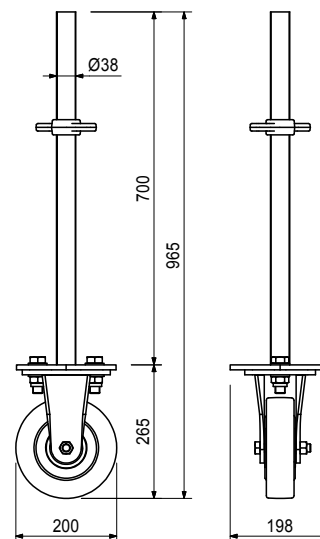
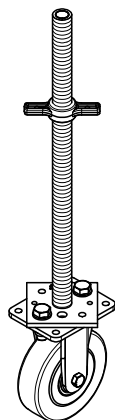

Accessories

100863 1.020

Spindle Locking UJS

Article no. Weight kg

101858 7.000

Castor UEW 12 with pin, galv.

Wheel for mobile scaffolds. Wheel bodies red.

Technical data

Permissible load – Locked state: 12 kN –
Running state: 6 kN

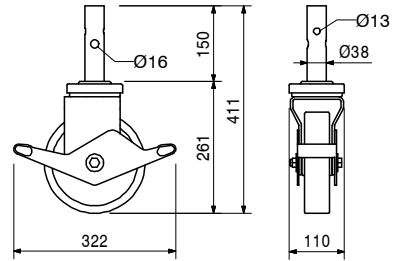
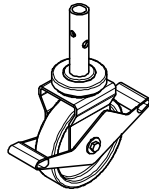

Accessories

111053 0.059
100719 0.060

Locking pin Ø 48/57

Bolt ISO 4014 M10 x 70-8.8

101860 7.500

Castor UEW 12 with spindle, galv.

Wheel for mobile scaffolds. Wheel bodies red.

Technical data

Permissible load up to 12 kN depending on spindle
extension and bracing.

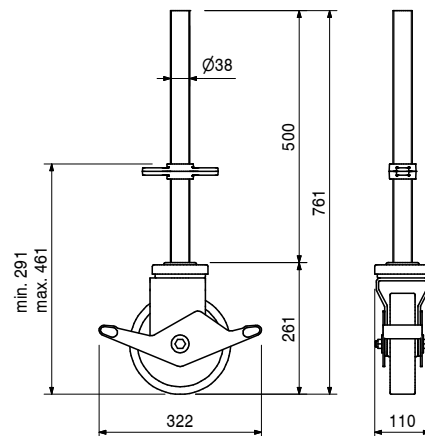
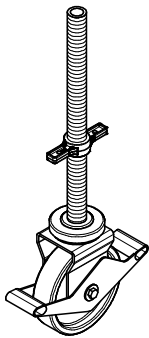

Accessories

100863 1.020

Spindle Locking UJS

100863 1.020

Spindle Locking UJS

Locks base spindles and section spindles
Ø 38 mm in the vertical during moving
procedures.

Technical data

Permissible load 1.5 kN.

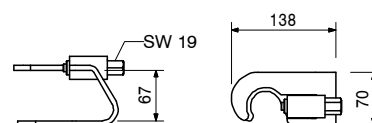

Article no. Weight kg

135187 3.590

Base Standard UVB 50

For assembling directly onto the base spindles.
Can also be used as 50 cm standard.

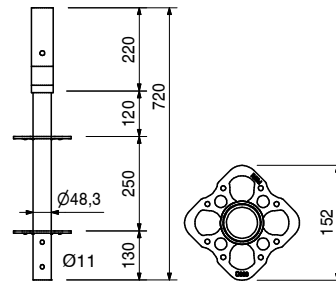
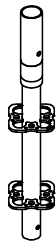

401309	2.510
400000	4.610
417195	5.590
400003	6.920
400005	9.230
400007	11.500

Top Standards UVH

Top Standard UVH 50

Top Standard UVH 100

Top Standard UVH 125

Top Standard UVH 150

Top Standard UVH 200

Top Standard UVH 250

Without pin for mounting head spindles.

L

500

1,000

1,250

1,500

2,000

2,500

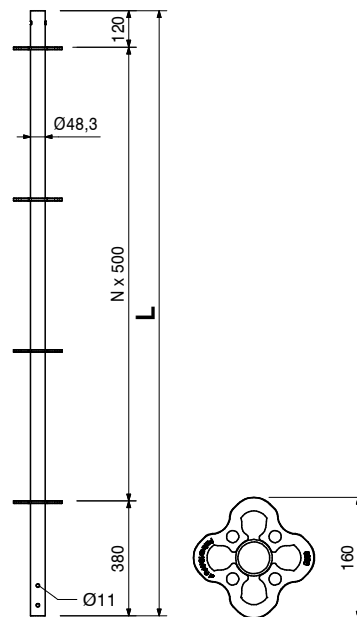
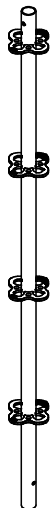

Article no. Weight kg

Article no.	Weight kg		L
132123	2.090	Top Standards UVH-2	500
132194	4.210	Top Standard UVH-2 50	1,000
132196	6.060	Top Standard UVH-2 100	1,250
132198	6.310	Top Standard UVH-2 125	1,500
132200	8.420	Top Standard UVH-2 150	2,000
132202	10.500	Top Standard UVH-2 200	2,500
		Top Standard UVH-2 250	

Without pin for mounting head spindles.

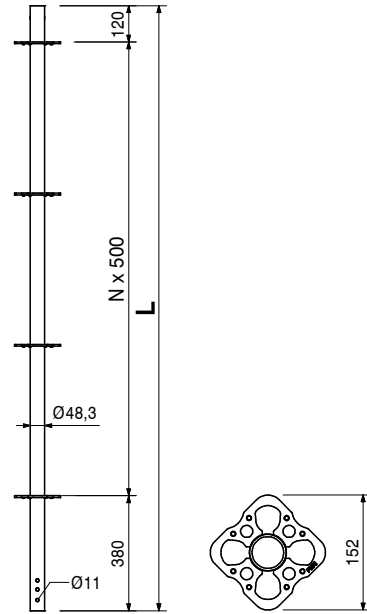

135972 4.310

Top Standard EVT 96

For completing the top section of the scaffold when using Console Bracket ECM in conjunction with Easy Standard EVM to increase the width of the scaffold.

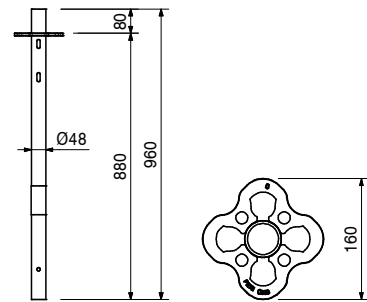
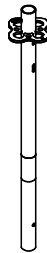

PERI UP Scaffolding Kit – Core components



Article no. Weight kg

Article no.	Weight kg	Standard UVR	L
402859	3.080	Standard UVR 50	500
401306	5.380	Standard UVR 100	1,000
402860	7.690	Standard UVR 150	1,500
400009	10.000	Standard UVR 200	2,000
400012	14.700	Standard UVR 300	3,000
400013	19.200	Standard UVR 400	4,000

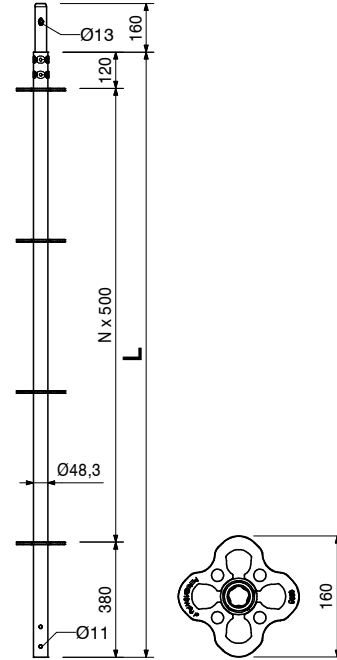
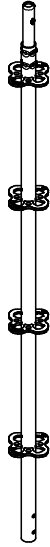

Article no.	Weight kg	Standards UVR-2	L
132219	2.490	Standard UVR-2 50	500
132224	4.350	Standard UVR-2 100	1,000
132229	6.190	Standard UVR-2 150	1,500
132234	8.040	Standard UVR-2 200	2,000
132239	11.700	Standard UVR-2 300	3,000

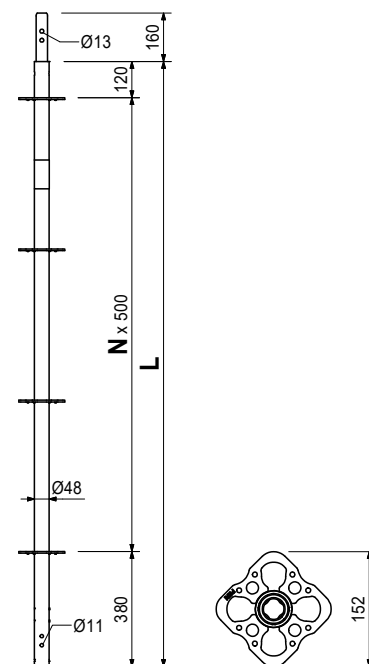
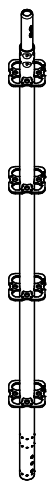

PERI UP Scaffolding Kit – Core components

Article no. Weight kg

Article no.	Weight kg	
414613	1.420	Horizontal Ledger UH Plus
414595	2.070	Horizontal Ledger UH 25 Plus
414629	2.730	Horizontal Ledger UH 50 Plus
414632	4.460	Horizontal Ledger UH 75 Plus
414638	5.430	Horizontal Ledger UH 100 Plus
414641	4.720	Horizontal Ledger UH 125 Plus
417032	5.380	Horizontal Ledger UH 175 Plus
414645	6.040	Horizontal Ledger UH 200 Plus
416356	6.700	Horizontal Ledger UH 225 Plus
414648	7.360	Horizontal Ledger UH 250 Plus
414651	8.680	Horizontal Ledger UH 300 Plus

L	X
204	250
454	500
704	750
954	1,000
1,204	1,250
1,454	1,500
1,704	1,750
1,954	2,000
2,204	2,250
2,454	2,500
2,954	3,000

Note

With length marking for easier identification.

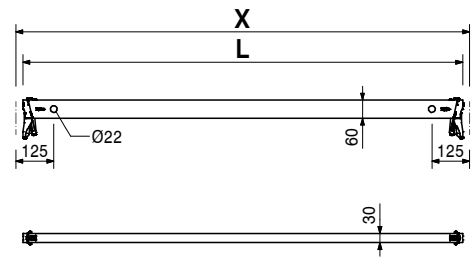
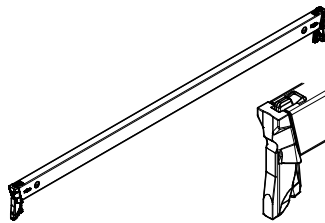

Article no.	Weight kg	
131995	1.410	Horizontal Ledger UH-2
133900	1.590	Horizontal Ledger UH-2 25
131998	2.030	Horizontal Ledger UH-2 33
133903	2.480	Horizontal Ledger UH-2 50
132213	2.690	Horizontal Ledger UH-2 67
132004	3.740	Horizontal Ledger UH-2 100
132007	4.510	Horizontal Ledger UH-2 125
132010	4.680	Horizontal Ledger UH-2 150
132013	5.340	Horizontal Ledger UH-2 175
132016	6.000	Horizontal Ledger UH-2 200
132019	6.660	Horizontal Ledger UH-2 225
132025	7.320	Horizontal Ledger UH-2 250
132022	8.650	Horizontal Ledger UH-2 300

L	X
204	250
284	330
454	500
624	670
704	750
954	1,000
1,204	1,250
1,454	1,500
1,704	1,750
1,954	2,000
2,204	2,250
2,454	2,500
2,954	3,000

Note

With length marking for easier identification.

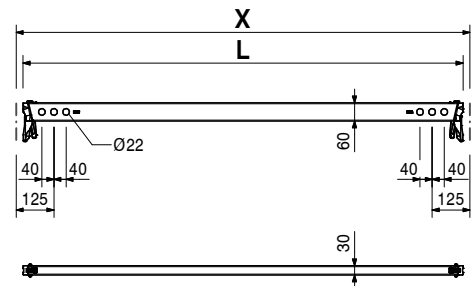
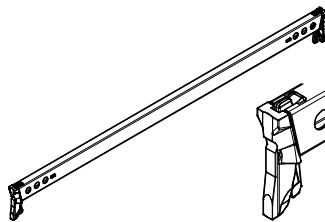

PERI UP Scaffolding Kit – Core components



Article no. Weight kg

Article no.	Weight kg		L	X
414681	10.900	Horizontal Ledger UHV Plus	1,454	1,500
414687	14.700	Horizontal Ledger UHV 150 Plus	1,954	2,000
414691	17.900	Horizontal Ledger UHV 200 Plus	2,454	2,500
414695	21.600	Horizontal Ledger UHV 250 Plus	2,954	3,000
		Horizontal Ledger UHV 300 Plus		

For high loads, e.g. in the case of material storage.

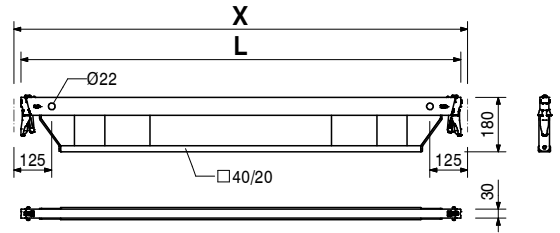
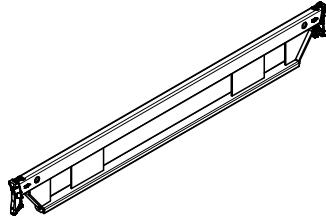

Article no.	Weight kg		L	X
137020	9.410	Horizontal Ledger UHV-2	1,454	1,500
137025	12.700	Horizontal Ledger UHV-2 150	1,954	2,000
137030	15.200	Horizontal Ledger UHV-2 200	2,454	2,500
137035	18.500	Horizontal Ledger UHV-2 250	2,954	3,000
		Horizontal Ledger UHV-2 300		

For high loads, e.g. in the case of material storage.

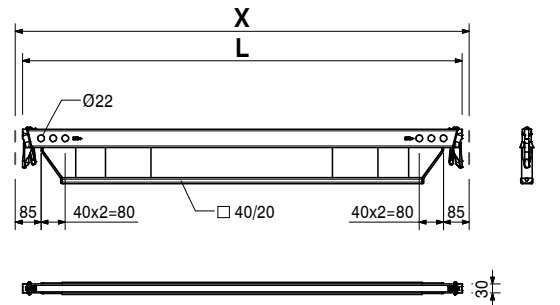
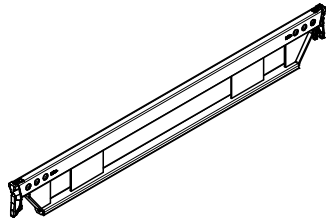

Article no. Weight kg

Article no.	Weight kg		L	X	Y
		Horizontal Braces UBH Flex			
114818	4.590	Horizontal Brace UBH Flex 100/100	1,335	1,000	1,000
114904	5.630	Horizontal Brace UBH Flex 125/125	1,689	1,250	1,250
114821	5.730	Horizontal Brace UBH Flex 150/100	1,725	1,500	1,000
114908	6.170	Horizontal Brace UBH Flex 150/125	1,874	1,500	1,250
114912	6.660	Horizontal Brace UBH Flex 150/150	2,042	1,500	1,500
114820	7.010	Horizontal Brace UBH Flex 200/100	2,161	2,000	1,000
124097	7.780	Horizontal Brace UBH Flex 200/150	2,422	2,000	1,500
114916	8.740	Horizontal Brace UBH Flex 200/200	2,749	2,000	2,000
114896	8.130	Horizontal Brace UBH Flex 250/75	2,541	2,500	750
114819	8.360	Horizontal Brace UBH Flex 250/100	2,620	2,500	1,000
114996	8.650	Horizontal Brace UBH Flex 250/125	2,720	2,500	1,250
124101	9.000	Horizontal Brace UBH Flex 250/150	2,838	2,500	1,500
114920	9.840	Horizontal Brace UBH Flex 250/200	3,123	2,500	2,000
114928	10.800	Horizontal Brace UBH Flex 250/250	3,456	2,500	2,500
114900	9.550	Horizontal Brace UBH Flex 300/75	3,025	3,000	750
114892	9.740	Horizontal Brace UBH Flex 300/100	3,092	3,000	1,000
124105	10.300	Horizontal Brace UBH Flex 300/150	3,279	3,000	1,500
114924	11.000	Horizontal Brace UBH Flex 300/200	3,528	3,000	2,000
114932	11.900	Horizontal Brace UBH Flex 300/250	3,826	3,000	2,500
114936	12.900	Horizontal Brace UBH Flex 300/300	4,163	3,000	3,000

For horizontal bracing of towers.

Can also be used underneath Decks UDG.

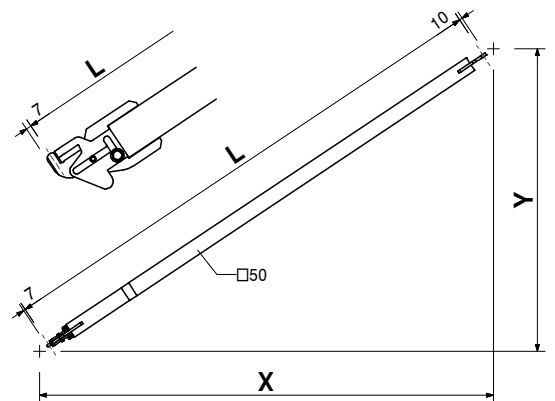
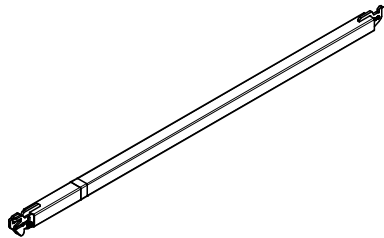

Article no. Weight kg

		Ledger Braces UBL		
		L	X	Y
415156	2.660	901	1,000	500
415513	4.640	1,677	1,000	1,500
415157	5.810	2,136	1,000	2,000
407867	3.790	1,347	1,500	500
400055	4.440	1,601	1,500	1,000
402846	5.340	1,953	1,500	1,500
400057	6.380	2,358	1,500	2,000
409034	6.740	2,500	1,750	2,000
404391	5.000	1,820	2,000	500
400059	5.500	2,016	2,000	1,000
402862	6.240	2,305	2,000	1,500
400061	7.160	2,658	2,000	2,000
430282	5.620	2,062	2,250	500
430283	6.070	2,236	2,250	1,000
417689	7.580	2,829	2,250	2,000
400063	6.640	2,462	2,500	1,000
402861	7.260	2,705	2,500	1,500
400065	8.050	3,010	2,500	2,000
404762	7.490	2,795	3,000	500
400067	7.830	2,926	3,000	1,000
404766	8.360	3,133	3,000	1,500
400069	9.050	3,400	3,000	2,000

They are attached using holes in the horizontal ledgers.

Note

Longitudinally-stamped with coloured label for easier identification.

UBL 150/250 identical to UBL 300/50.

UBL 225/150 identical to UBL 175/200.

UBL 250/50 identical to UBL 200/150

UBL 75/200 identical to UBL 225/50.

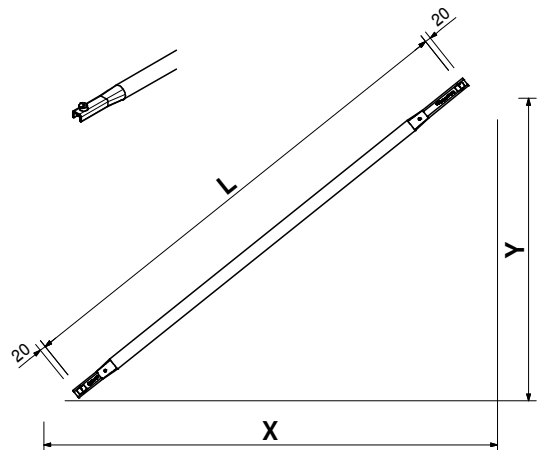
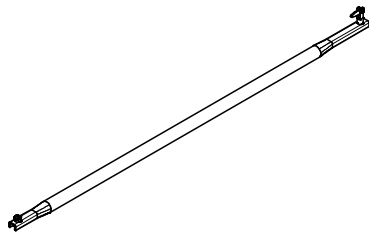

Article no. Weight kg

Article no.	Weight kg		L	X	Y
		Ledger Braces UBL-2			
132771	2.140	Ledger Brace UBL-2 100/50	901	1,000	500
132773	2.830	Ledger Brace UBL-2 100/100	1,250	1,000	1,000
132775	3.680	Ledger Brace UBL-2 100/150	1,677	1,000	1,500
132777	4.600	Ledger Brace UBL-2 100/200	2,136	1,000	2,000
132779	3.030	Ledger Brace UBL-2 150/50	1,347	1,500	500
132781	3.530	Ledger Brace UBL-2 150/100	1,601	1,500	1,000
132783	4.230	Ledger Brace UBL-2 150/150	1,953	1,500	1,500
132785	5.040	Ledger Brace UBL-2 150/200	2,358	1,500	2,000
132787	5.330	Ledger Brace UBL-2 175/200	2,500	1,750	2,000
132789	3.970	Ledger Brace UBL-2 200/50	1,820	2,000	500
132791	4.360	Ledger Brace UBL-2 200/100	2,016	2,000	1,000
132793	4.940	Ledger Brace UBL-2 200/150	2,305	2,000	1,500
132795	5.640	Ledger Brace UBL-2 200/200	2,658	2,000	2,000
132797	4.450	Ledger Brace UBL-2 225/50	2,062	2,250	500
132808	4.800	Ledger Brace UBL-2 225/100	2,236	2,250	1,000
132810	5.980	Ledger Brace UBL-2 225/200	2,829	2,250	2,000
132812	5.250	Ledger Brace UBL-2 250/100	2,462	2,500	1,000
132814	5.730	Ledger Brace UBL-2 250/150	2,705	2,500	1,500
132816	6.340	Ledger Brace UBL-2 250/200	3,010	2,500	2,000
132827	5.920	Ledger Brace UBL-2 300/50	2,795	3,000	500
132829	6.180	Ledger Brace UBL-2 300/100	2,926	3,000	1,000
132831	6.590	Ledger Brace UBL-2 300/150	3,133	3,000	1,500
132833	7.120	Ledger Brace UBL-2 300/200	3,400	3,000	2,000

Note

Longitudinally-stamped with coloured label for easier identification.

UBL-2 150/250 identical to UBL-2 300/50.

UBL-2 225/150 identical to UBL-2 175/200.

UBL-2 250/50 identical to UBL-2 200/150

UBL-2 75/200 identical to UBL-2 225/50.

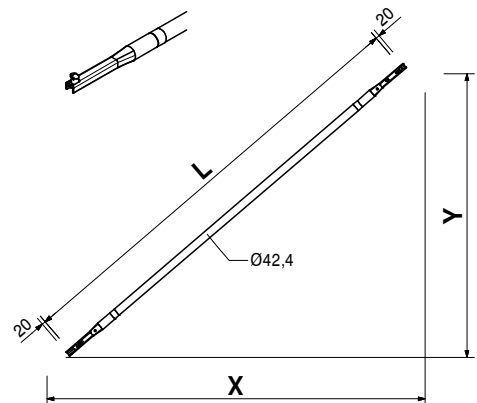
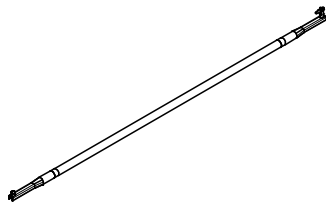

Article no. Weight kg

		Node Braces UBK		
Article no.	Weight kg	L	X	Y
424170	6.780	2,190	750	2,000
412926	6.990	2,285	1,000	2,000
415354	5.220	1,625	1,250	1,000
412765	7.260	2,401	1,250	2,000
400981	5.710	1,821	1,500	1,000
400973	6.580	2,152	1,500	1,500
400572	7.600	2,539	1,500	2,000
400985	6.790	2,246	2,000	1,000
406630	7.510	2,521	2,000	1,500
400573	8.390	2,860	2,000	2,000
400989	7.940	2,696	2,500	1,000
406624	8.540	2,930	2,500	1,500
400574	9.310	3,226	2,500	2,000
400993	9.130	3,131	3,000	1,000
400575	10.300	3,625	3,000	2,000

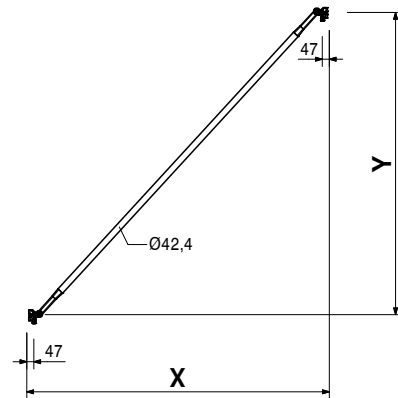
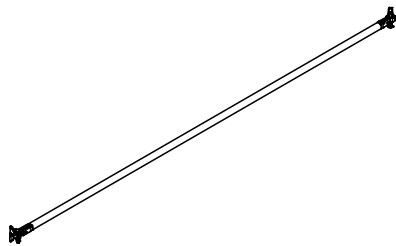

		Node Braces UBK-2		
Article no.	Weight kg	L	X	Y
133418	4.980	2,190	750	2,000
133421	5.130	2,285	1,000	2,000
133424	3.900	1,625	1,250	1,000
133427	5.320	2,401	1,250	2,000
133430	4.240	1,821	1,500	1,000
133433	4.840	2,152	1,500	1,500
133436	5.550	2,539	1,500	2,000
133439	4.990	2,246	2,000	1,000
133442	5.490	2,521	2,000	1,500
133445	6.100	2,860	2,000	2,000
133448	5.790	2,696	2,500	1,000
133451	6.210	2,930	2,500	1,500
133454	6.740	3,226	2,500	2,000
133457	6.620	3,131	3,000	1,000
133460	6.980	3,356	3,000	1,500
133463	7.440	3,625	3,000	2,000

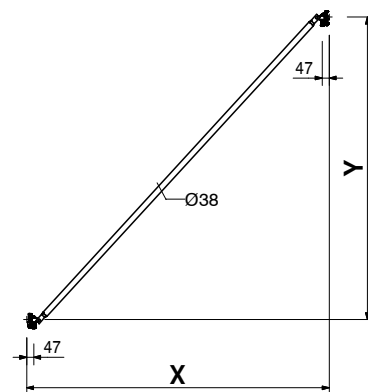
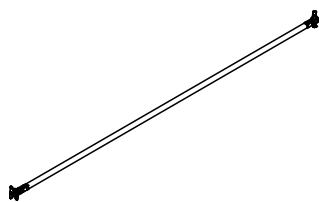

PERI UP Scaffolding Kit – Core components

Article no. Weight kg

		Coupler Braces UBC-2
131750	7.330	Coupler Brace UBC-2 67-100/200
131726	9.020	Coupler Brace UBC-2 150/200
131741	10.100	Coupler Brace UBC-2 200/200
131744	11.300	Coupler Brace UBC-2 250/200
131747	12.500	Coupler Brace UBC-2 300/200

L	X	Y
1,750	670	2,000
2,305	1,500	2,000
2,657	2,000	2,000
3,052	2,500	2,000
3,473	3,000	2,000

For special applications.
For connecting scaffolding tubes \varnothing 48 mm.

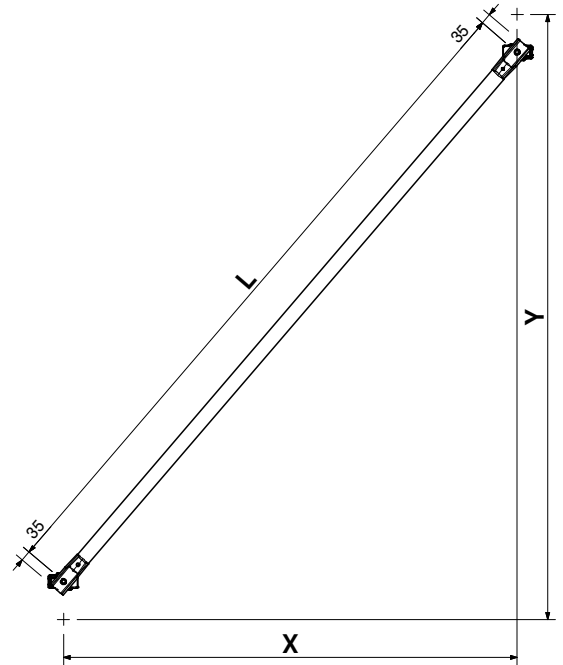
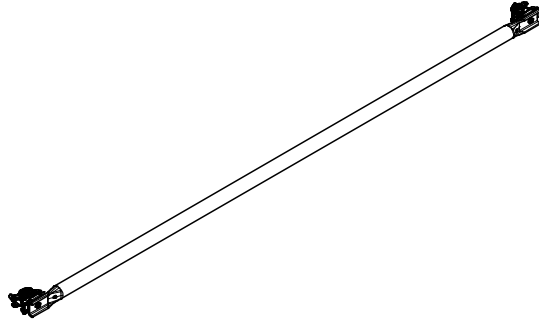

		Shoring Braces UBS
128936	4.250	Shoring Braces UBS 100/100
129354	5.300	Shoring Braces UBS 100/150
107801	5.260	Shoring Braces UBS 150/100
107810	6.050	Shoring Braces UBS 150/150
115504	6.360	Shoring Braces UBS 200/100
115291	7.050	Shoring Braces UBS 200/150
123592	7.630	Shoring Braces UBS 250/100
123588	8.090	Shoring Braces UBS 250/150
123584	8.820	Shoring Braces UBS 300/100
123580	9.360	Shoring Braces UBS 300/150

L	X	Y
1,413	1,000	1,000
1,771	1,000	1,500
1,792	1,500	1,000
2,122	1,500	1,500
2,219	2,000	1,000
2,492	2,000	1,500
2,672	2,500	1,000
2,902	2,500	1,500
3,139	3,000	1,000
3,337	3,000	1,500

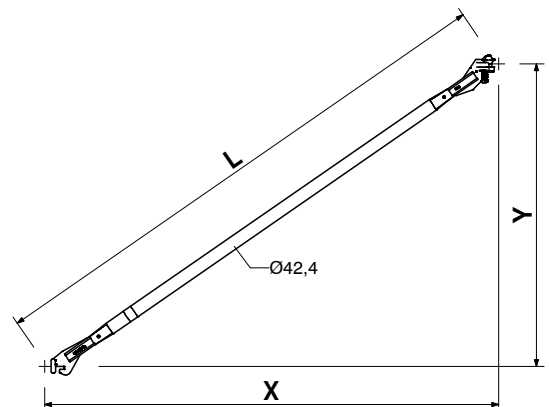
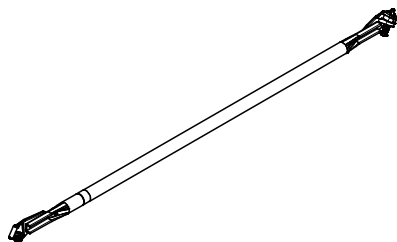

Article no. Weight kg

134542 0.606

Toe Board Compensation UPY-L

Connection component for connection of 2 x Toe Boards UPY.

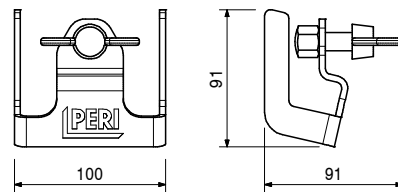
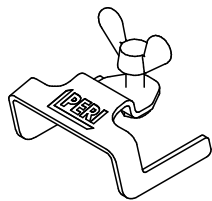

		Steel Toe Boards UPY
132592	0.414	Steel Toe Board UPY 25
110213	0.929	Steel Toe Board UPY 50
110514	1.450	Steel Toe Board UPY 75
110073	1.960	Steel Toe Board UPY 100
134628	2.480	Steel Toe Board UPY 125
110160	2.990	Steel Toe Board UPY 150
110176	4.030	Steel Toe Board UPY 200
110208	5.060	Steel Toe Board UPY 250
110211	6.090	Steel Toe Board UPY 300

L	X
236	250
486	500
736	750
986	1,000
1,236	1,250
1,486	1,500
1,986	2,000
2,486	2,500
2,986	3,000

Note

- Default surface: galvanised and painted in yellow.

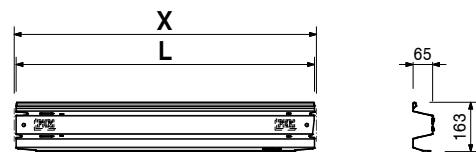
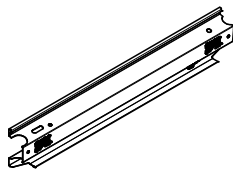

		Wood Toe Boards UPF
129490	1.180	Wood Toe Board UPF 50
129494	1.720	Wood Toe Board UPF 75
129496	2.250	Wood Toe Board UPF 100
129498	3.320	Wood Toe Board UPF 150
129500	4.390	Wood Toe Board UPF 200
129502	5.460	Wood Toe Board UPF 250
129504	6.520	Wood Toe Board UPF 300

X
500
750
1,000
1,500
2,000
2,500
3,000

Note

- Default surface: painted yellow.

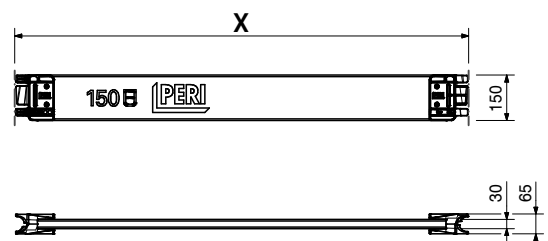
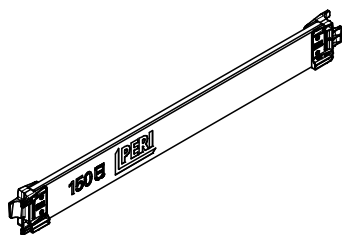

PERI UP Scaffolding Kit – Core components



Article no. Weight kg

				L	X
		Guardrail Posts EPG			
130193	1.680	Guardrail Post EPG 100		1,065	1,000
130195	2.480	Guardrail Post EPG 150		1,565	1,500
130197	3.280	Guardrail Post EPG 200		2,065	2,000
130199	4.090	Guardrail Post EPG 250		2,565	2,500
130201	4.890	Guardrail Post EPG 300		3,065	3,000

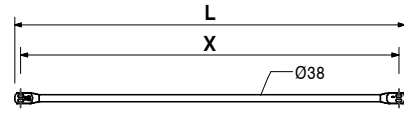
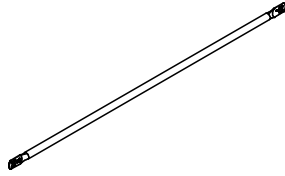

				L	X
		Swing Ledger UPK			
410072	3.910	Swing Ledger UPK 75		704	750
416695	4.470	Swing Ledger UPK 100		954	1,000
417192	4.240	Swing Ledger UPK 125		1,204	1,250

Access opening to the top.

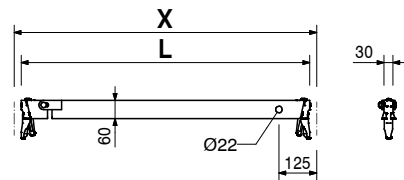
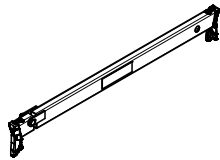

				L
		Safety Entry Gates UPS		
125672	9.470	Safety Entry Gate UPS 75		747
126675	11.100	Safety Entry Gate UPS 100		996

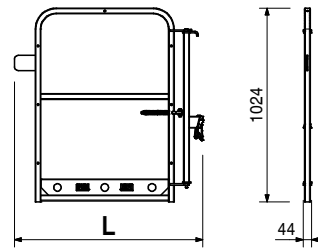
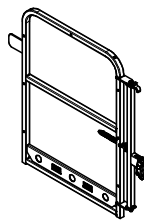

PERI UP Scaffolding Kit – Core components



Article no. Weight kg

Article no.	Weight kg		L	X
134102	7.000	End Guardrail in Advance UPA-2	881	750
134104	8.100	End Guardrail in Advance UPA-2 75	1,131	1,000
		End Guardrail in Advance UPA-2 100		

Assembly in advance.

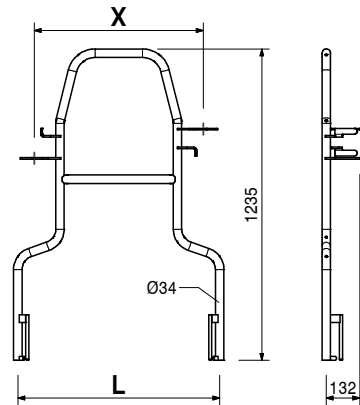
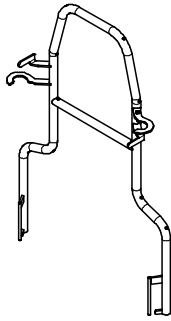

Article no.	Weight kg		L	X
115959	1.160	Supports UC		
		Support UC 25	250	223
130390	1.360	Support UC 33	330	301

Note

Small console brackets with limit stop for fixing the decks in place.

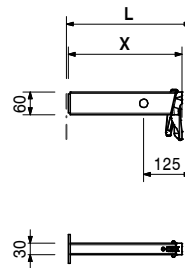
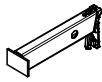

136050	1.880	Support UCS 33		
--------	-------	-----------------------	--	--

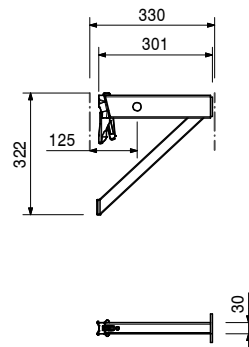
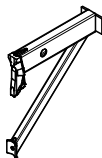

Article no. Weight kg

112717 7.320

Bracket Brace UCM

For increasing the load-bearing capacity of Console Brackets UCM 50 and UCM 75 with a yellow coupling.

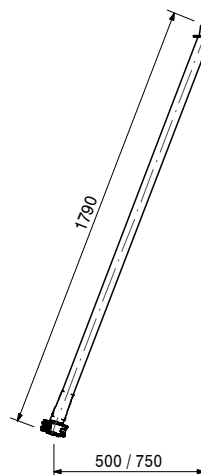
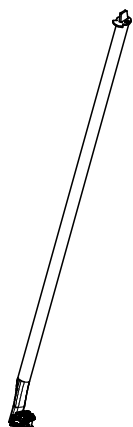

130378 4.550

Console Bracket ECM 33

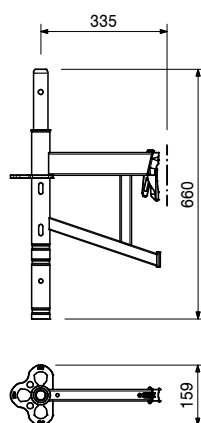
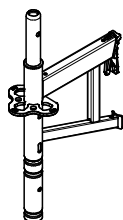

136923 5.910

Console Bracket ECM 50

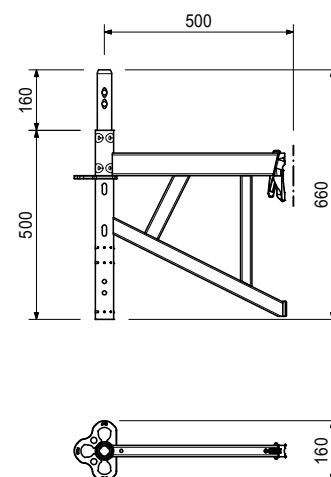
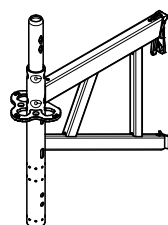

PERI UP Scaffolding Kit – Core components



Article no. Weight kg

130372 7.430 **Console Bracket ECM 67**

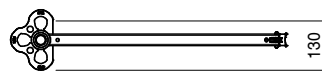
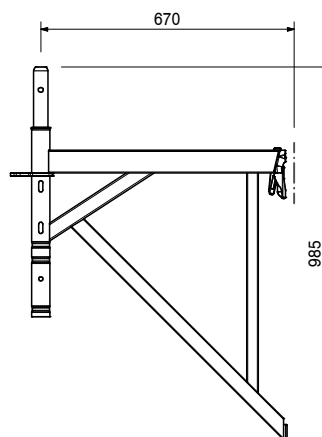
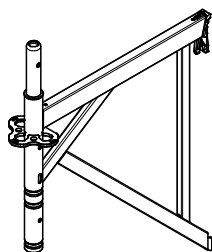

136918 7.710 **Console Bracket ECM 75**

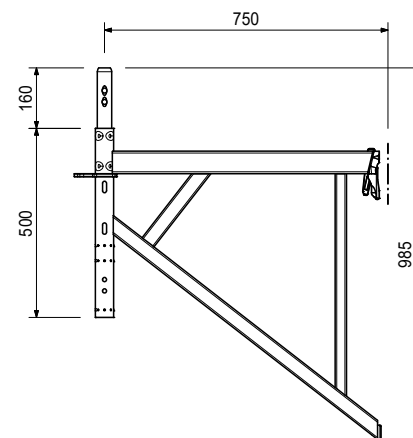
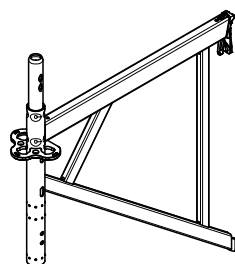

PERI UP Scaffolding Kit – Core components



Article no. Weight kg

130365 11.200 **Console Bracket ECM 100**

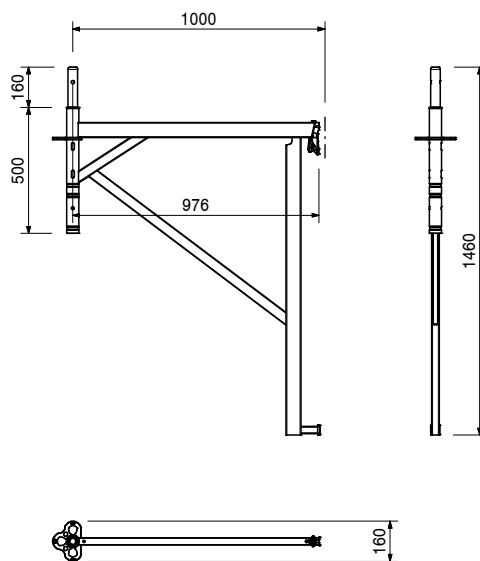
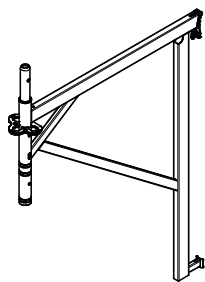

130532 6.640

Protection Panel Post EPS
For assembling a protection panel.

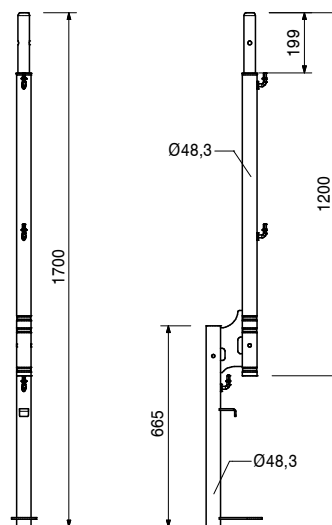

130512 3.720

Accessories
Guardrail Post EVP

Article no. Weight kg

134005	2.710	Console Bracket UCB 25
--------	-------	-------------------------------

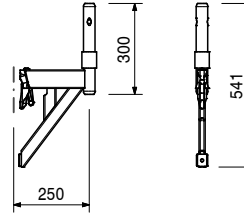
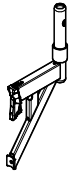

112690	4.370	Console Brackets UCM with Semi-Rosette
412693	5.610	Console Bracket UCM 50 with semi-rosette Console Bracket UCM 75 with semi-rosette

With connection for Console Bracket Brace UCM.

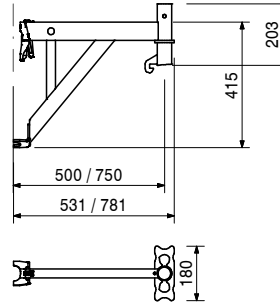
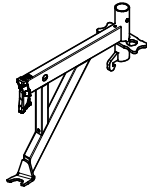

111053	0.059	Accessories
100301	0.969	Locking pin Ø 48/57 Connector ULT 32

412676	5.270	Console Brackets UCM with spigot
412678	6.510	Console Bracket UCM 50 with spigot Console Bracket UCM 75 with spigot

With connection for Console Bracket Brace UCM.

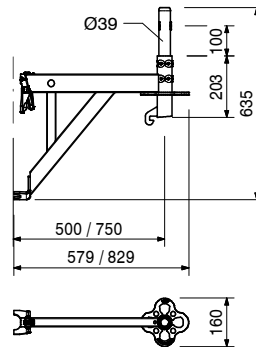
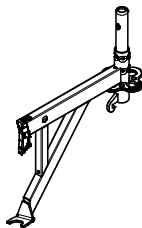

Article no. Weight kg

110483	4.470
111128	5.710

Console Bracket UCM
Console Bracket UCM 50-2
Console Bracket UCM 75-2

With connection for Console Bracket Brace UCM.

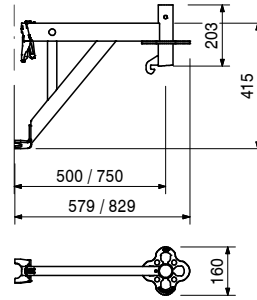
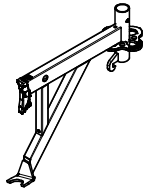

Accessories

111053	0.059
100301	0.969

Locking pin Ø 48/57
Connector ULT 32

424124	3.880
432858	4.810
424121	5.260
424118	6.630
424115	8.010
424112	9.410
424109	12.200
423771	14.900
424915	17.700

Steel Decks UDG 25
Steel Deck UDG 25 x 50
Steel Deck UDG 25 x 67
Steel Deck UDG 25 x 75
Steel Deck UDG 25 x 100
Steel Deck UDG 25 x 125
Steel Deck UDG 25 x 150
Steel Deck UDG 25 x 200
Steel Deck UDG 25 x 250
Steel Deck UDG 25 x 300

Fit onto Horizontal Ledgers UH.

X	perm. p [kN/m ²]	max. p [kN/m ²]
500	6.0	40.0
670	6.0	40.0
750	6.0	40.0
1,000	6.0	40.0
1,250	6.0	28.4
1,500	6.0	19.6
2,000	6.0	10.9
2,500	4.5	6.9
3,000	3.0	4.7

Note

Values corresponding to EN 12811-1.
 max. p = max. possible surface load without deflection restriction.

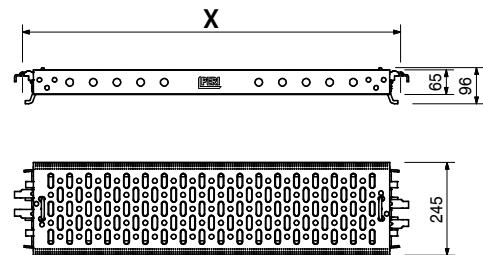
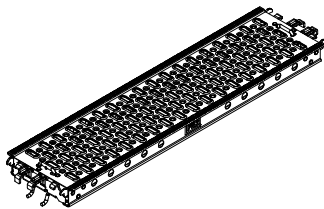

PERI UP Scaffolding Kit – Core components



Article no. Weight kg

Article no.	Weight kg	Description
132479	3.190	Steel Decks UDG-2 25
132483	3.960	Steel Deck UDG-2 25 x 50
132488	4.320	Steel Deck UDG-2 25 x 67
132492	5.450	Steel Deck UDG-2 25 x 75
132502	6.590	Steel Deck UDG-2 25 x 100
132505	7.730	Steel Deck UDG-2 25 x 125
132508	10.500	Steel Deck UDG-2 25 x 150
132511	12.900	Steel Deck UDG-2 25 x 200
132515	15.800	Steel Deck UDG-2 25 x 250
		Steel Deck UDG-2 25 x 300
		Length X: 500 – 1,500 with H of 45 mm
		Length X: 2,000 – 2,500 with H of 60 mm
		Length X: 3,000 with H of 70 mm

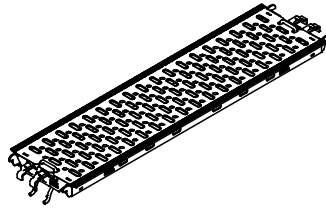

X	perm. p [kN/m ²]
500	6.0
670	6.0
750	6.0
1,000	6.0
1,250	6.0
1,500	6.0
2,000	6.0
2,500	4.5
3,000	3.0

Note
Values correspond with EN 12811-1

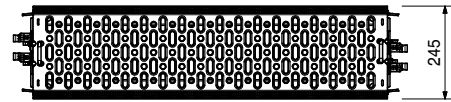
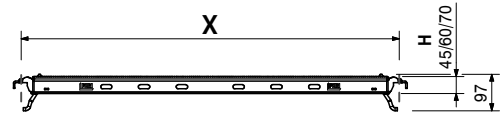

Article no.	Weight kg	Description
130450	5.420	Steel Decks EDS 33
130448	7.360	Steel Deck EDS 33 x 67
130445	10.300	Steel Deck EDS 33 x 100
130441	13.300	Steel Deck EDS 33 x 150
130438	16.200	Steel Deck EDS 33 x 200
129272	19.200	Steel Deck EDS 33 x 250
		Steel Deck EDS 33 x 300
		Installation on crossbar of the frame components
		or on Horizontal Ledger UH.

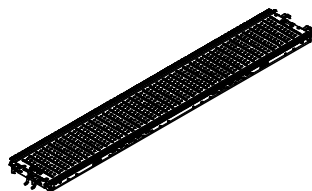

X	perm. p [kN/m ²]
670	6.0
1,000	6.0
1,500	6.0
2,000	6.0
2,500	4.5
3,000	3.0

Note
Values correspond with EN 12811-1.

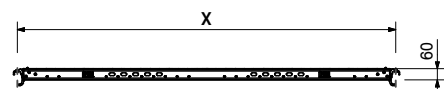

136927	2.780	Cover Plate UDB 20 x 100
--------	-------	---------------------------------

Note
Load class 3, 2.0 kN/m²

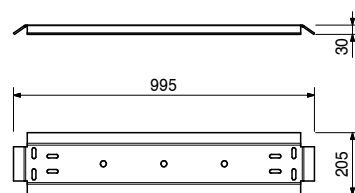
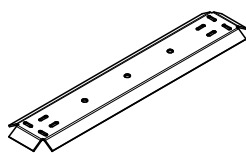

Accessories		
137252	0.200	FLRD screw M 10 x 60 DIN 603, 8.8, galv.
137279	0.100	Hex nut ISO 4032 M10-8, galv. SW17

Article no. Weight kg

136925	4.250	Cover Plate UDB 20 x 150
--------	-------	---------------------------------

Note

Load class 3, 2.0 kN/m²

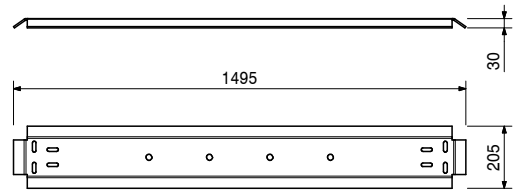
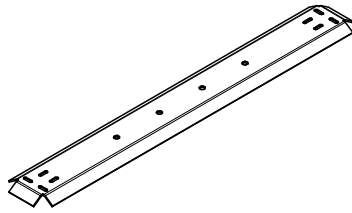

Accessories

137279	0.100	Hex nut ISO 4032 M10-8, galv. SW17
137252	0.200	FLRD screw M 10 x 60 DIN 603, 8.8, galv.

136832	0.000	Cover Plate UDP
111101	7.780	Cover Plate UDP 67
112809	10.900	Cover Plate UDP 75
		Cover Plate UDP 100

Cover Plate UDP
Cover Plate UDP 67
Cover Plate UDP 75
Cover Plate UDP 100

Fit onto Horizontal Ledgers UH. Closes deck gaps between scaffolding bays in the scaffolding of circular buildings.

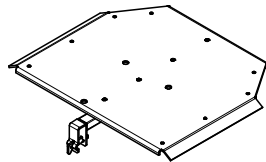

Technical data

Load Class 3, 2.0 kN/m²

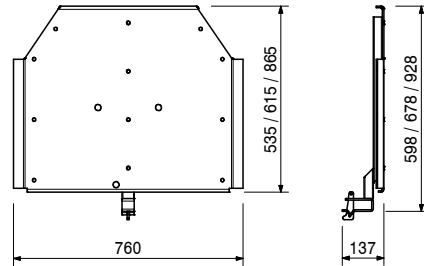

134537	2.710	Corner Plates UDC
114148	4.890	Corner Plate UDC 50
113358	10.000	Corner Plate UDC 75
		Corner Plate UDC 100

Corner Plates UDC
Corner Plate UDC 50
Corner Plate UDC 75
Corner Plate UDC 100

Fit onto Horizontal Ledgers UH. For inside corners of platforms on round containers.

	L	X
	458	458
	705	705
	965	965

Technical data

Load Class 3, 2.0 kN/m².

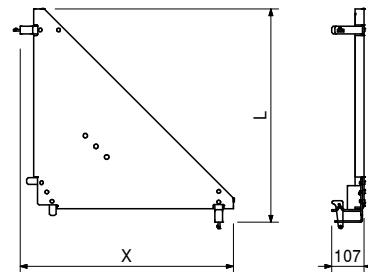
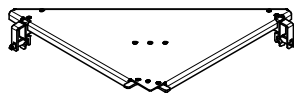

PERI UP Scaffolding Kit – Core components



Article no. Weight kg

		Inside Corner Plates EDP	
134549	2.800	Inside Corner Plate EDP 25	L
134552	4.940	Inside Corner Plate EDP 33	290

			378

Note
Load Class 4, 3.0 kN/m².

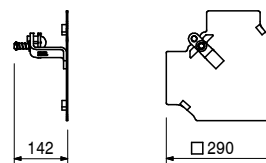
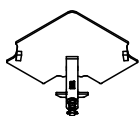

136786 2.450 **Deck Traverse UDT 25**

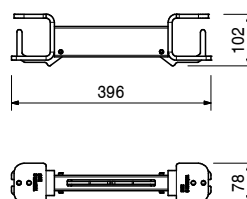
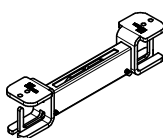

136790 3.110 **Deck Traverse UDT 50**

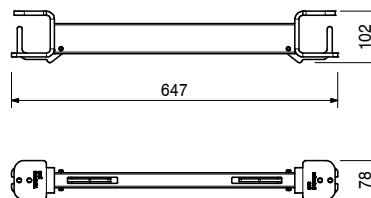
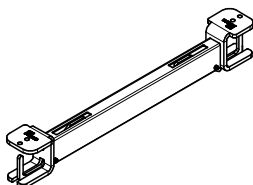

136794 3.780 **Deck Traverse UDT 75**

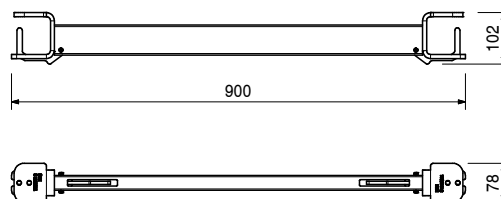
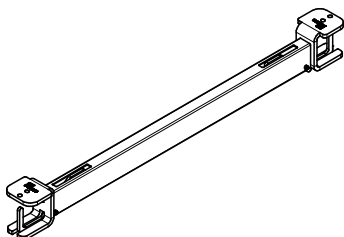

PERI UP Scaffolding Kit – Core components



Article no. Weight kg

109783	9.320
109755	15.600

Passages UAF
Passage UAF 50 x 75
Passage UAF 75 x 100
 Fit onto Horizontal Ledgers UH.

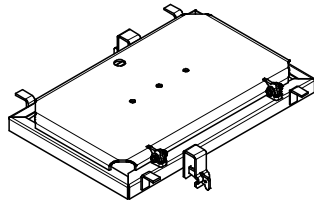

Technical data
 Load Class 6 = 6.0 kN/m²

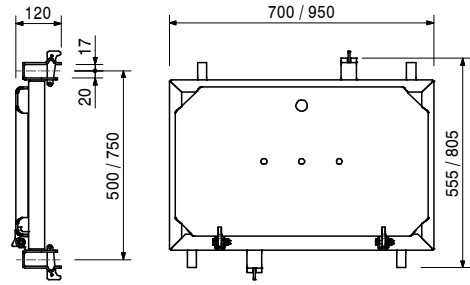

Accessories
Ladder UAF 200, Aluminium

109879	3.820
--------	-------

Entry Platforms UAA
Entry Platform UAA 75 x 150
Entry Platform UAA 75 x 200

132993	16.000
132990	19.100

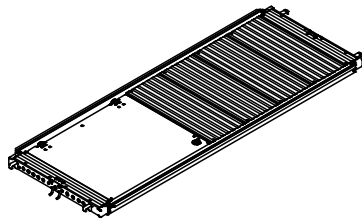

X
 1,500
 2,000
Technical data
 Load Class 3 = 2.0 kN/m²

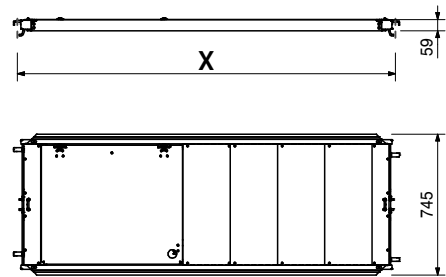

Accessories
Ladder UAF 200, Aluminium

109879	3.820
--------	-------

Entry Platforms UAC 75
Passage Deck UAC 75 x 150
Passage Deck UAC 75 x 200

136197	14.400
135373	18.500

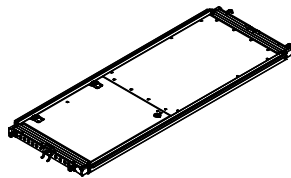

Technical data
 Load Class 3 = 2.0 kN/m²

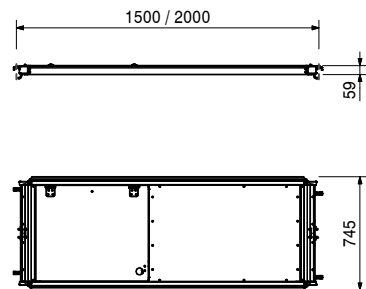

Accessories
Ladder UAF 200, Aluminium

109879	3.820
--------	-------

Article no. Weight kg

134046	14.100
132996	17.900

Entry Platforms UAW 75
Passage Deck UAW 75 x 150
Passage Deck UAW 75 x 200
 Installation on Crossbars and Horizontal Ledgers UH.

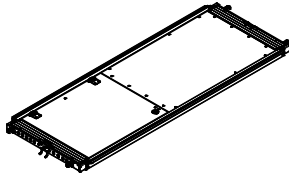

Technical data
 Load Class 3 = 2.0 kN/m²

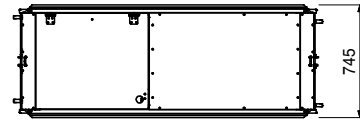
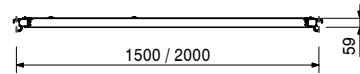

109879	3.820
--------	-------

Accessories
Ladder UAF 200, Aluminium

133314	27.000
133315	30.300

Access Decks UAA 75
Access Deck UAA 75 x 250-L
Access Deck UAA 75 x 300-L
 Installation on Crossbars or Horizontal Ledgers UH.

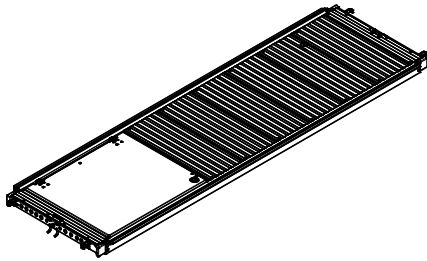

Technical data
 Load Class 3 = 2.0 kN/m²

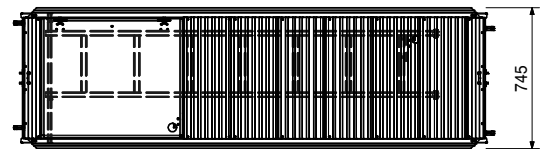
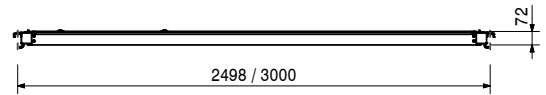

135372	26.600
135371	30.700

Access Decks UAC 75
Access Deck UAC 75 x 250-L
Access Deck UAC 75 x 300-L
 Aluminium spar profile with glass-fibre reinforced plastic trapdoor. Installation on Crossbars or Horizontal Ledgers UH. Lateral hatch.

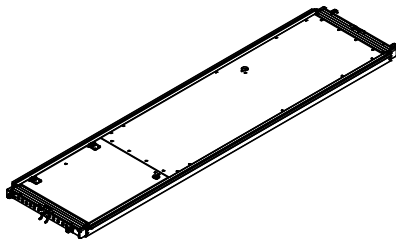

Technical data
 Load Class 3 = 2.0 kN/m²

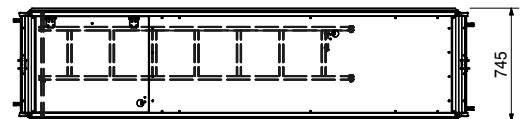
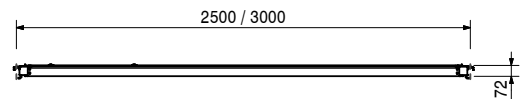

PERI UP Scaffolding Kit – Core components



Article no. Weight kg

130334	25.900
133309	29.700

Access Decks UAW 75
Access Deck UAW 75 x 250-L
Access Deck UAW 75 x 300-L

Installation on crossbars or Horizontal Ledgers UH.

Note

Load Class 3 = 2.0 kN/m²

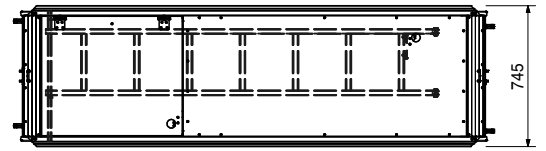
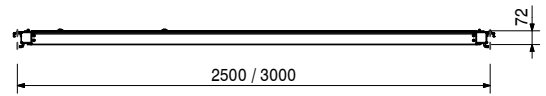
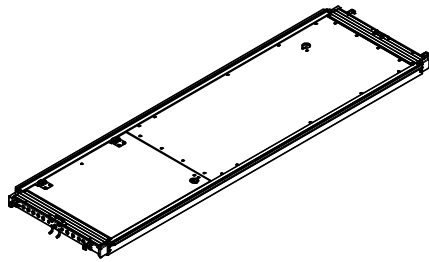

109879 3.820

Ladder UAF 200, Aluminium

To mount on the Entry Platform EAW, EAA, EAC 200.

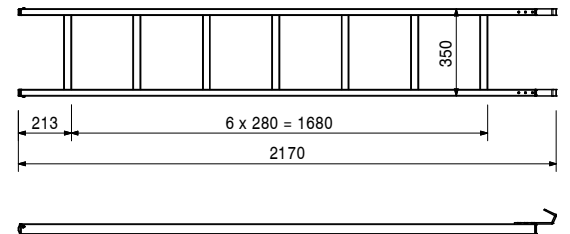
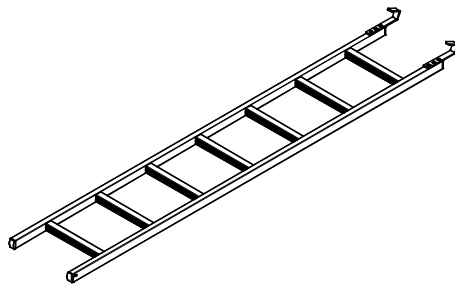

134512 1.990

Ladder Connector Diagonal UAD

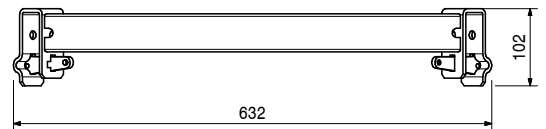
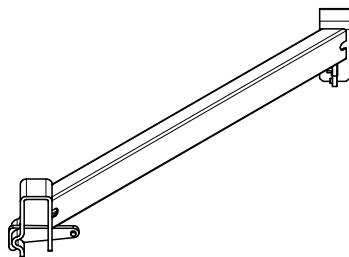

134520 1.670

Ladder Connector Ledger UAM-S

Is used to attach ladders up to maximum stile size 25 x 80 mm or round tubes up to $\varnothing = 48.3$ mm.

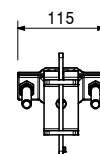
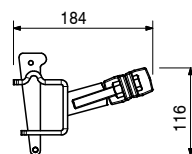
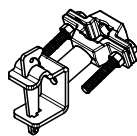

PERI UP Scaffolding Kit – Core components



Article no. Weight kg

134527 1.670

Ladder Connector Ledger UAM-W

Is used to attach ladders up to max. stile size 30 x 60 mm.

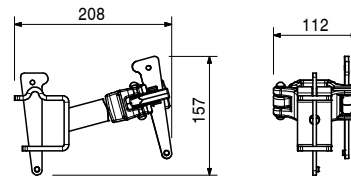
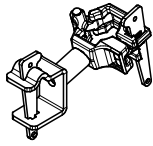

051410 11.700

Ladder 180/6, galv.

For accessing PERI formwork systems.

Complete with

4 pc. 710224 bolt ISO 4017 M12 x 40-8.8, galv.
4 pc. 710381 nut ISO 7040 M12-8, galv.

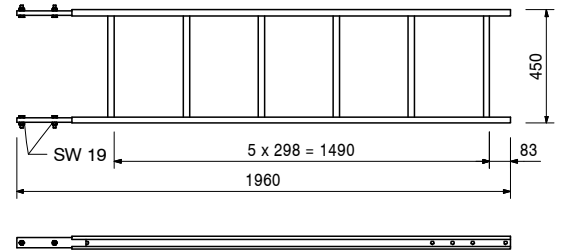
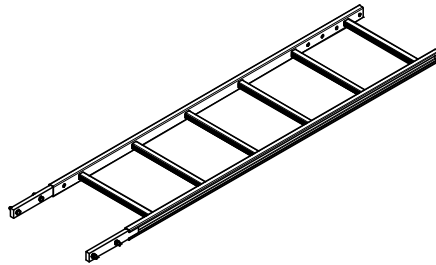

135529 5.840

Ladder Aluminium UAI 300-A

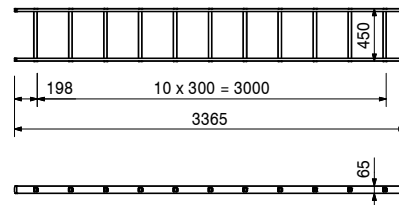
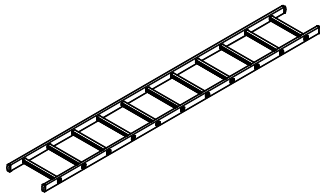

135530 7.590

Ladder Aluminium UAI 400-A

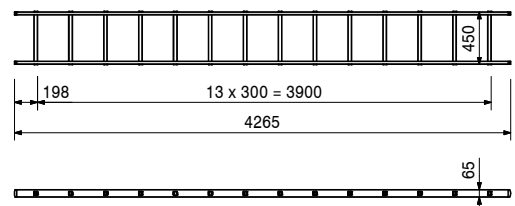
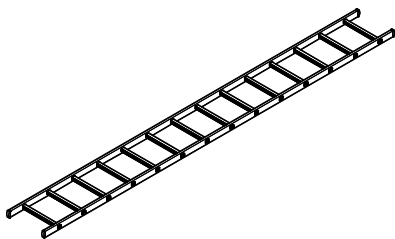

Article no. Weight kg

135531 10.100 **Ladder Aluminium UAI 500-A**

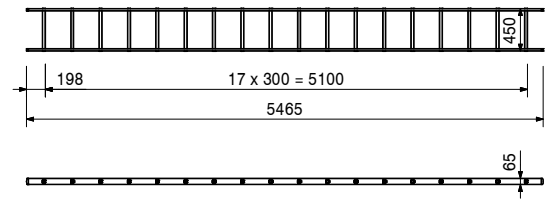
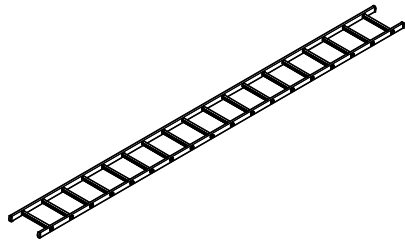

051460 2.180 **Ladder base, galv.**

As bottom ladder connection and for securing ladders against sliding on the scaffold decks.

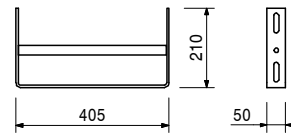
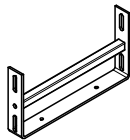

104132 15.600
051450 25.200

Ladder cage
Ladder Cage 75, galv.
Ladder Cage 150, galv.

Ladder cage for PERI ladder access.

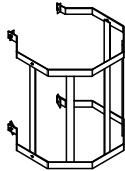

Complete with

4 pc. 710266 bolt ISO 4017 M12 x 25-8.8, galv.
4 pc. 701763 Clamping Plate FI 25 x 10 x 90

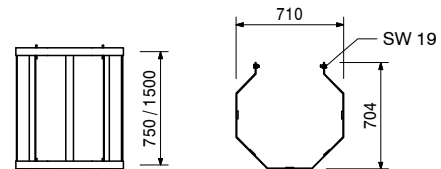

124813 4.000 **Ladder Connector UAC-2**

Note

Connects Ladder 180/6 (Article No. 051410) with PERI UP Standards.

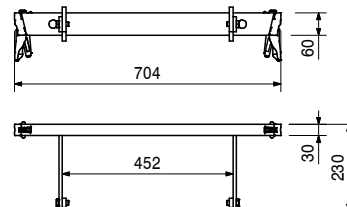
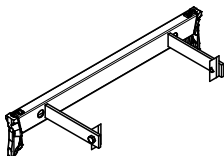

Accessories

051410 11.700 **Ladder 180/6, galv.**
051460 2.180 **Ladder base, galv.**
103724 10.400 **Access ladder 180/2, galv.**
104132 15.600 **Ladder Cage 75, galv.**
051450 25.200 **Ladder Cage 150, galv.**

PERI UP Scaffolding Kit – Core components



Article no. Weight kg

Article no.	Weight kg		L	N
133310	4.652	Ladders UAV	930	2
133311	8.751	Vertical Ladder UAV 43 x 91	1,828	5
		Vertical Ladder UAV 43 x 181		

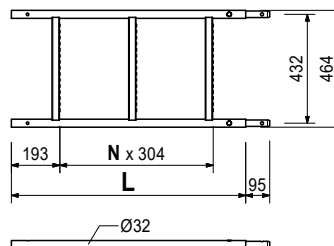
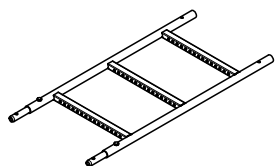

133312	3.620	Ladder Connector UAV 43-C
--------	-------	----------------------------------

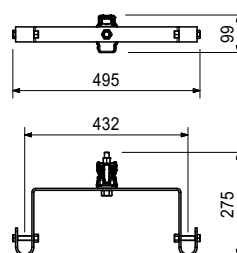
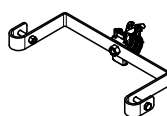

100742	10.000	Stair Guardrail UAG
--------	--------	----------------------------

Suitable for Staircases UAS and EAS as internal and external guardrails.

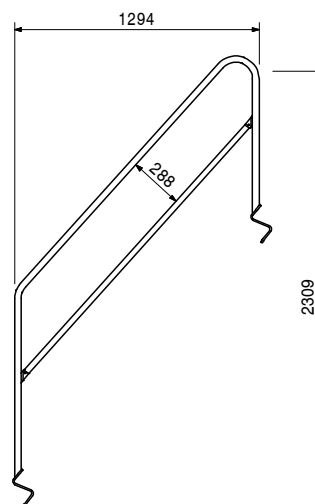
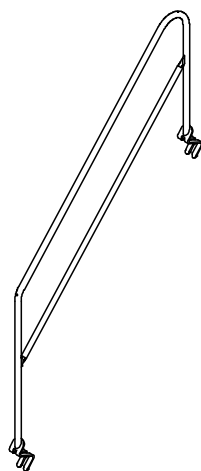

Article no. Weight kg

400830 4.970

Stair Guardrail UAH

For fixing to the stringers of the Staircases UAS.

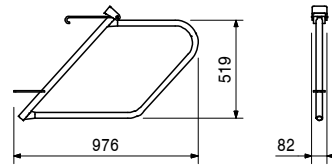
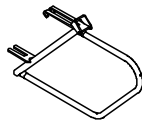

133543 4.510

Stair Guardrail UAH-2

For fixing to the stringers of the Staircases UAS and EAS.

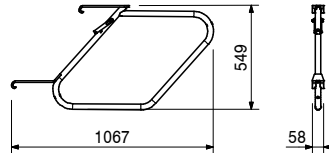
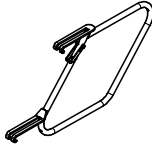

411117 28.000

411124 32.900

Stair Towers UAS 75, Aluminium

Stair Tower UAS 75 x 250/200, Aluminium

Stair Tower UAS 75 x 300/200, Aluminium

Fit onto Horizontal Ledgers UH.

Technical data

Load Class 3 = 2.0 kN/m²

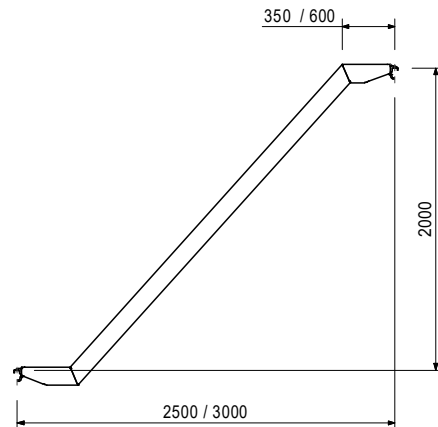
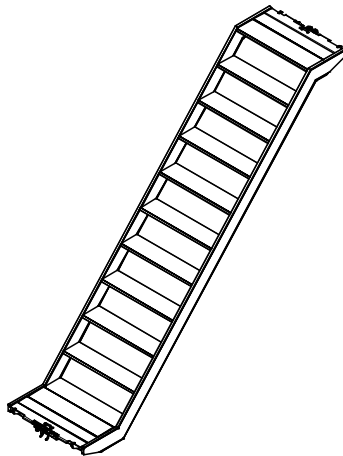

413228 10.100

Stair Tower UAS 75 x 75/50, Aluminium

Fit onto Horizontal Ledgers UH.

Technical data

Load Class 3 = 2.0 kN/m²

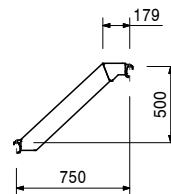
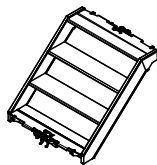

Article no. Weight kg

411087 17.500

Stair Tower UAS 75 x 150/50 T, Aluminium
Fit onto Horizontal Ledgers UH.

Technical data
Load Class 3 = 2.0 kN/m²

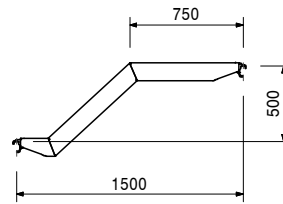
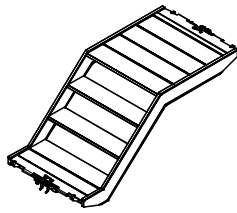

411095 17.500

Stair Tower UAS 75 x 150/50 S, Aluminium
Fit onto Horizontal Ledgers UH.

Technical data
Load Class 3 = 2.0 kN/m²

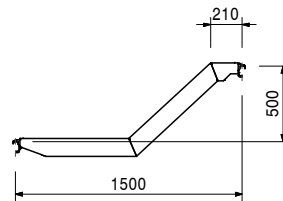
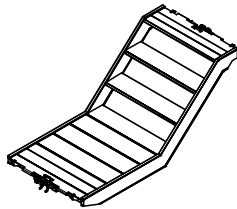

414536 17.900

Stair Tower UAS 75 x 150/100 S, Aluminium
Fit onto Horizontal Ledgers UH.

Technical data
Load Class 3 = 2.0 kN/m²

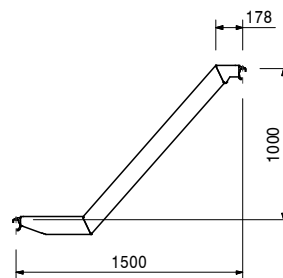
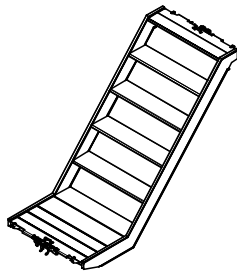

411103 17.900

Stair Tower UAS 75 x 150/100, Aluminium
Fit onto Horizontal Ledgers UH.

Technical data
Load Class 3 = 2.0 kN/m²

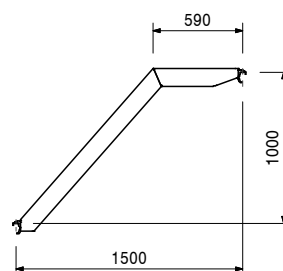
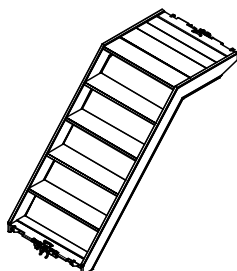

Article no. Weight kg

134562 29.700

Flex Stair UAS-2 75 x 250/200
Fit onto Horizontal Ledger UH

Technical data

Permissible load 2.0 kN/m²
Class B according to DIN EN 12811-1.

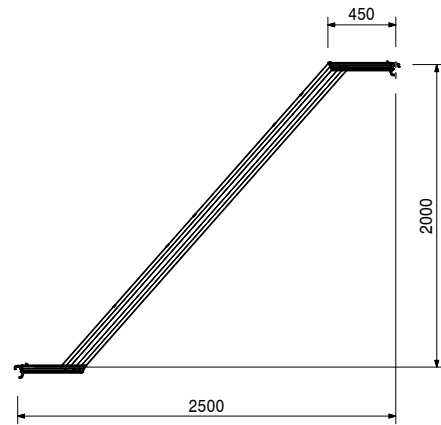

134561 33.300

Flex Stair UAS-2 75 x 300/200
Fit onto Horizontal Ledger UH

Technical data

Permissible load 2.0 kN/m²
Class B according to DIN EN 12811-1.

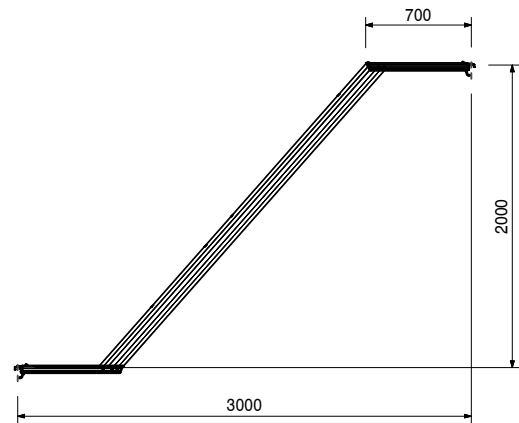
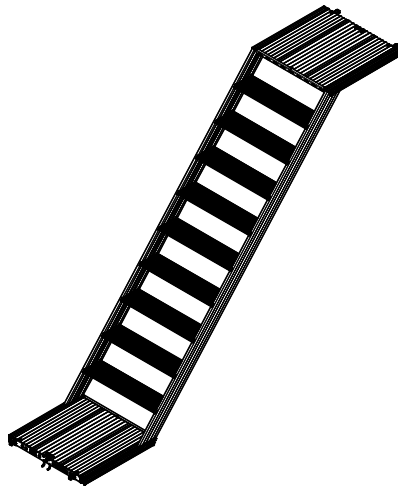

134556 11.800

Flex Stair UAS-2 75 x 75/50
Fit onto Horizontal Ledger UH

Technical data

Permissible load 2.0 kN/m²
Class B according to DIN EN 12811-1.

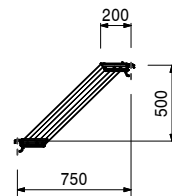
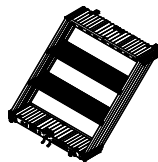

Article no. Weight kg

134563 17.300

Flex Staircase UAS-2 75 x 150/50T
Fit onto Horizontal Ledger UH

Technical data

Permissible load 2.0 kN/m²
Class B according to DIN EN 12811-1.

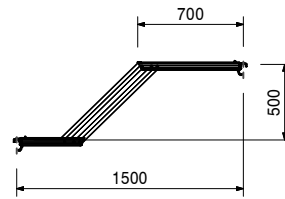
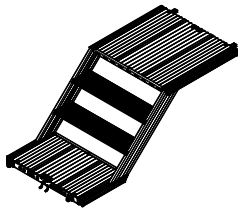

134564 17.300

Flex Staircase UAS-2 75 x 150/50S
Fit onto Horizontal Ledger UH

Technical data

Permissible load 2.0 kN/m²
Class B according to DIN EN 12811-1.

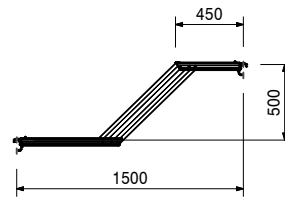

134557 18.200

Flex Staircase UAS-2 75 x 150/100T
Fit onto Horizontal Ledger UH

Technical data

Permissible load 2.0 kN/m²
Class B according to DIN EN 12811-1.

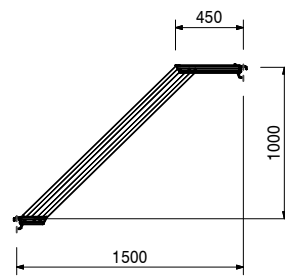
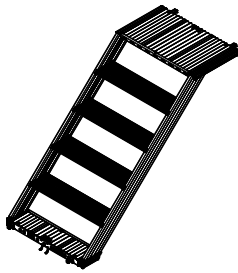

134558 18.200

Flex Staircase UAS-2 75 x 150/100S
Fit onto Horizontal Ledger UH

Technical data

Permissible load 2.0 kN/m²
Class B according to DIN EN 12811-1.

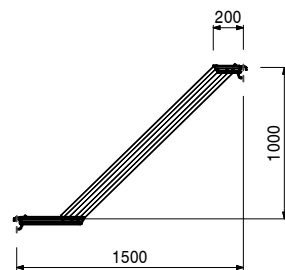

Article no. Weight kg

		Easy Staircases EAS 67
134553	27.000	Easy Staircase EAS 67 x 250/200
134554	29.600	Easy Staircase EAS 67 x 300/200

Technical data

Permissible load 2.0 kN/m²
Class B according to DIN EN 12811-1.

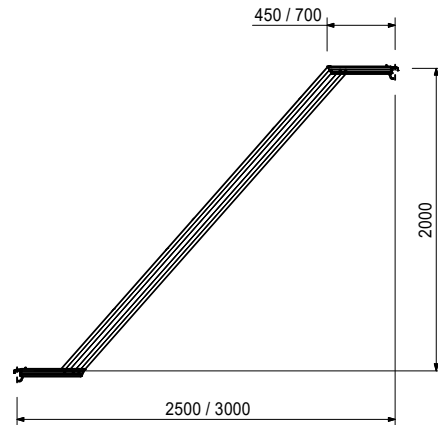

134555	10.700	Easy Staircase EAS 67 x 75/50 Fit onto Horizontal Ledger UH
--------	--------	---

Technical data

Permissible load 2.0 kN/m²
Class B according to DIN EN 12811-1.

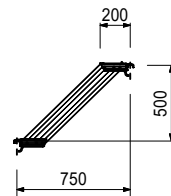
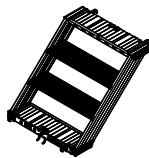

134559	16.500	Easy Staircase EAS 67 x 150/100 T Fit onto Horizontal Ledger UH
--------	--------	---

Technical data

Permissible load 2.0 kN/m²
Class B according to DIN EN 12811-1.

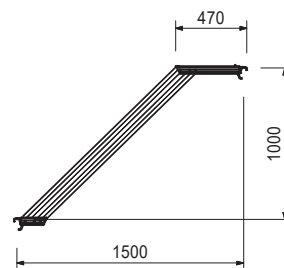
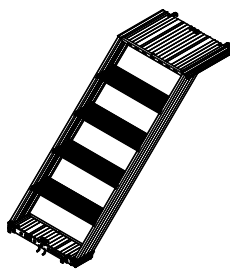

Article no. Weight kg

133739 2.000 **Spacer UEC-2**

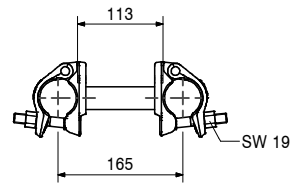
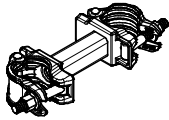

134204 1.500 **Flange Coupling UEF**

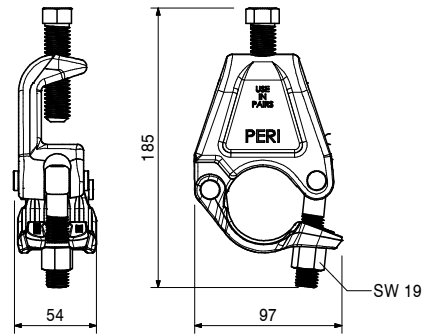
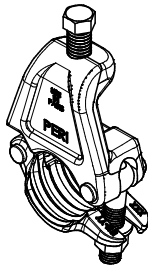

116306 1.700 **Clamping Rosette UEV 180 °**

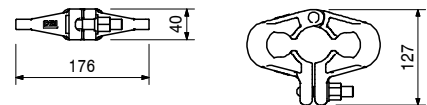
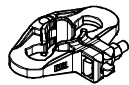

413726 1.230 **Flange Coupling UEC**
For connecting scaffolding tubes to steel beams with flange.

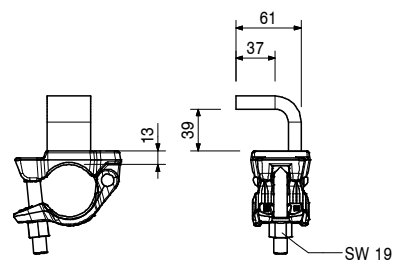
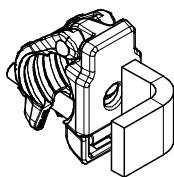

126453 1.630 **Clamping Rosette UEV 90°**

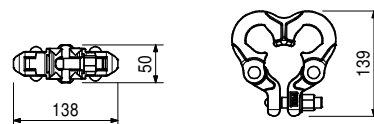
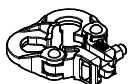

Article no. Weight kg

137211 1.600 **Coupling connection for UH 30/60**

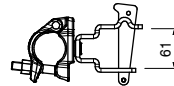
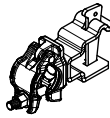

405824 1.480 **Coupling connection for UH**

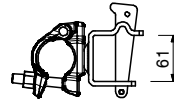
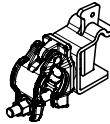

100909 1.000 **Tube connector Ø 48.3 mm, galv.**
Shear connector of scaffolding tubes Ø 48 mm.

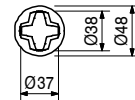
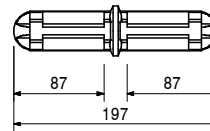
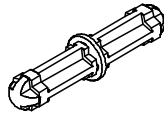

Accessories

100908 1.400 **Tension coupler Ø 48.3 mm, galv.**

100908 1.400 **Tension coupler Ø 48.3 mm, galv.**
For tension connection of scaffolding tubes Ø 48 mm.

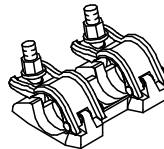

Accessories

100909 1.000 **Tube connector Ø 48.3 mm, galv.**

017020 1.120 **Standard Coupler RA 48/48, galv.**
For scaffolding tubes Ø 48 mm.

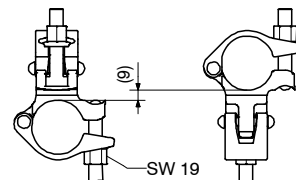
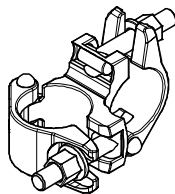

017010 1.400 **Swivel Coupling AF 48/48, galv.**
For scaffolding tubes Ø 48 mm.

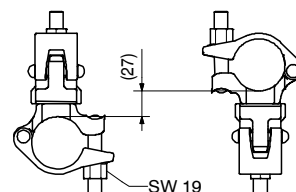
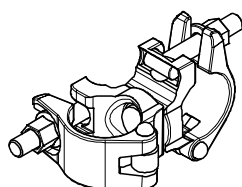

Article no. Weight kg

102400 1.100

Red. Swivel Coupling RS 38/48, galv.
For scaffolding tubes \varnothing 48 and \varnothing 38 mm.

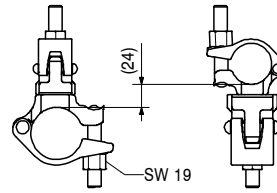
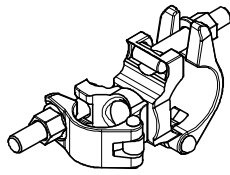

134108 1.580

Adapter Suspended Scaffold UEH
Suitable for suspending scaffolds. Further construction with Standard UVR or pin with Spacer Tube URE 4/42 in conjunction with Starter Tube ULB to mount formwork girders.

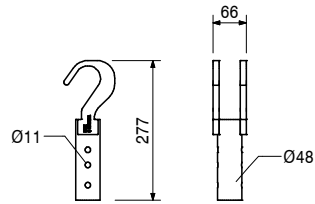
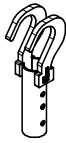

130562 0.623

Guardrail Holder EPW
For installing the Guardrail Posts EPG to rosettes.

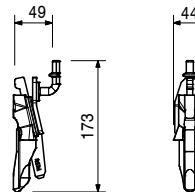

130434 1.100

Guardrail Coupling EPR
For installing the Guardrail Posts EPG on the verticals at any height.

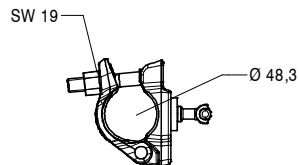
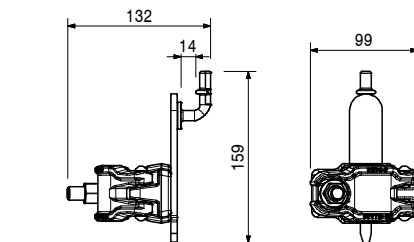
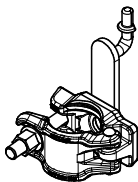

Article no. Weight kg

130684 2.020

Ledger-to-Ledger Coupler UHA-2 half with spigot

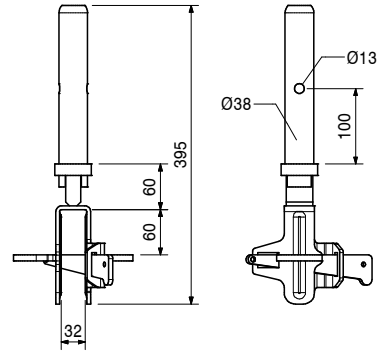
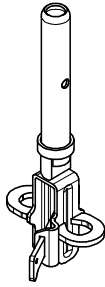

410792 1.900

Ledger-to-Ledger Coupler UHA half with spigot

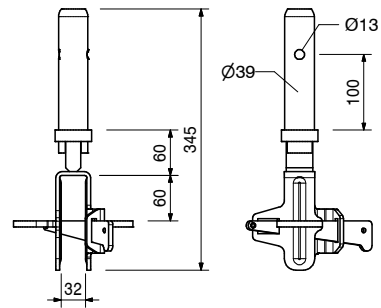
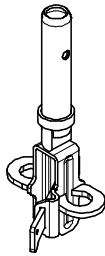

136582 0.829

Ledger-to-Ledger Coupler UHA-2
For connecting horizontal ledgers at right-angles.

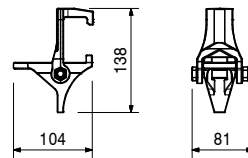
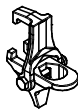

401731 0.841

Ledger-to-Ledger Coupler UHA
For connecting horizontal ledgers at right-angles.

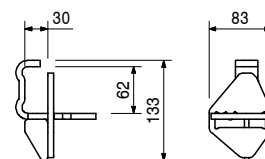

PERI UP Scaffolding Kit – Core components



Article no. Weight kg

110793 1.090 **Ledger-to-Ledger Coupler UHA half**

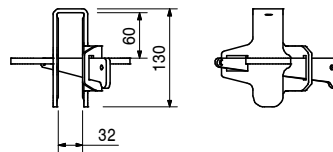
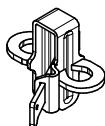

130681 1.360 **UH Spigot-2**

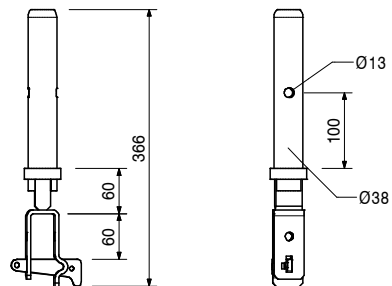
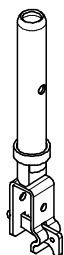

409764 1.250 **UH Spigot**

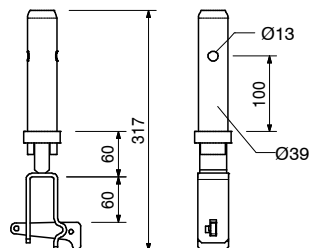
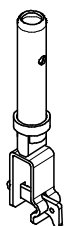

Article no. Weight kg

111053 0.059

Locking pin Ø 48/57

As tension-proof connection of verticals with a diameter of 48 up to 57 mm.

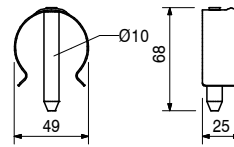

100719 0.060

Bolt ISO 4014 M10 x 70-8.8

As a tension-resistant connection of verticals for suspended scaffolds or formwork girders.

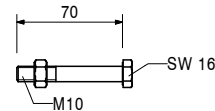
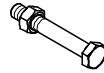

100301 0.969

Connector ULT 32

Single pin for connection of tubes Ø 48.3 x 3.2 mm, e.g. formwork girders or top standards without interlock.

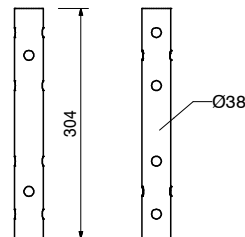

Accessories

111053 0.059

Locking pin Ø 48/57

100719 0.060

Bolt ISO 4014 M10 x 70-8.8

105372 1.340

Pin w. Spacer Tube URE 4/42

For attaching to Element Collar URP, Connector ULS Flex and Head Frame EVH. Spacer tube enables further installation in the system grid.

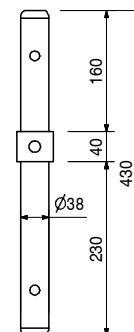

Accessories

780356 0.011

Nut ISO 7040 M10-8, galv.

100719 0.060

Bolt ISO 4014 M10 x 70-8.8

PERI UP Scaffolding Kit – Core components



Article no. Weight kg

Article no.	Weight kg		L
100088	1.920	Wall Tie UWT	488
100091	4.680	Wall Tie UWT 45	1138
100093	5.870	Wall Tie UWT 110	1438
102951	7.060	Wall Tie UWT 140	1738
102954	9.050	Wall Tie UWT 170	2238
102957	11.000	Wall Tie UWT 220	2738
		Wall Tie UWT 270	

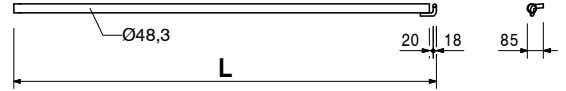
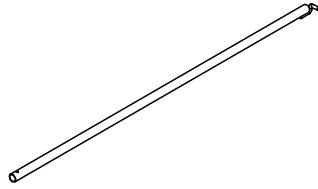

Article no.	Weight kg		Note
100693	0.169	Eyebolts UFE	With marking for screw-in depth.
100694	0.190	Eyebolt UFE 12/90	
100695	0.250	Eyebolt UFE 12/120	
		Eyebolt UFE 12/190	
For assembly of the Wall Tie UWT. Required Expanding Dowel UFI 14.			

Article no.	Weight kg	
100696	0.007	Expanding Dowel UFI
100697	0.009	Expanding Dowel UFI 14/70
100698	0.010	Expanding Dowel UFI 14/100
		Expanding Dowel UFI 14/135

Article no.	Weight kg		L
026415	3.550	Steel scaffolding tube Ø 48.3 x 3.2	
026417	0.000	Steel scaffolding tube Ø 48.3 x 3.2, special length	
026411	3.550	Cutting costs for scaffolding tubes	1,000
026412	7.100	Steel scaffolding tube Ø 48.3 x 3.2, L = 1.0 m	2,000
026413	10.650	Steel scaffolding tube Ø 48.3 x 3.2, L = 2.0 m	3,000
026414	14.200	Steel scaffolding tube Ø 48.3 x 3.2, L = 3.0 m	4,000
026419	17.750	Steel scaffolding tube Ø 48.3 x 3.2, L = 4.0 m	5,000
026418	21.600	Steel scaffolding tube Ø 48.3 x 3.2, L = 5.0 m	6,000
		Steel scaffolding tube Ø 48.3 x 3.2, L = 6.0 m	

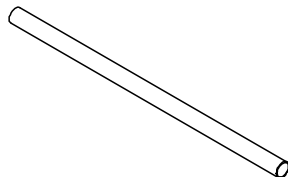

PERI UP Scaffolding Kit – Core components



Article no. Weight kg

Article no.	Weight kg	Formwork Girder Alu ULA
101656	18.300	Formwork Girder Alu ULA 50/425 HD
101657	22.400	Formwork Girder Alu ULA 50/525 HD
101658	26.400	Formwork Girder Alu ULA 50/625 HD
101659	37.300	Formwork Girder Alu ULA 70/825 HD

For bridging of openings.
For system-independent application.

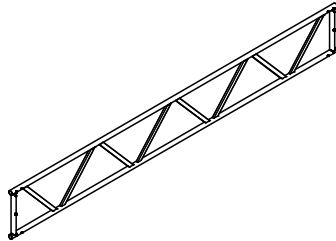

L	X	Y
4,250	4,000	500
5,250	5,000	500
6,250	6,000	500
8,250	8,000	700

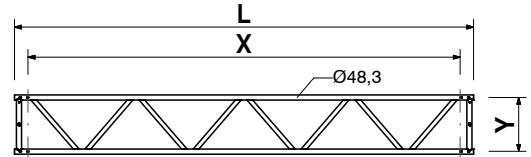

Article no.	Weight kg	Formwork Girder Steel ULS
100330	41.700	Formwork Girder Steel ULS 50/425
100336	50.900	Formwork Girder Steel ULS 50/525
100339	60.200	Formwork Girder Steel ULS 50/625
100185	54.800	Formwork Girder Steel ULS 70/525

For bridging of openings.
For system-independent application.

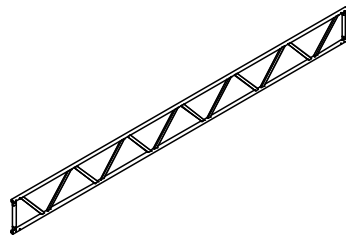

L	X	Y
4,250	4,000	500
5,250	5,000	500
6,250	6,000	500
5,250	5,000	700

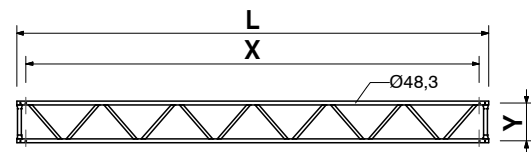

Article no.	Weight kg	Multi Girder ELM
131368	25.800	Multi Girder ELM e.g. suitable for the use of pavement gantries!

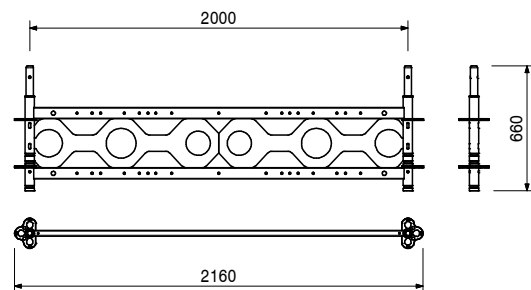
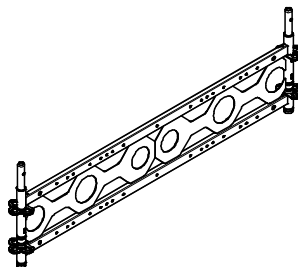

Accessories
UH Spigot-2
Ledger-to-Ledger Coupler UHA-2 half with spigot

130681	1.360
130684	2.020

Article no. Weight kg

124805 6.480 **End Element ULS 50 Flex**

Note

End piece for attachment to Intermediate Element ULS Flex.

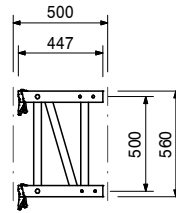
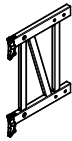

		Intermediate Elements ULS Flex	L	X
124795	10.500	Intermediate Element ULS 100 Flex	941	1,000
124790	12.700	Intermediate Element ULS 125 Flex	1,191	1,250
124781	15.400	Intermediate Element ULS 150 Flex	1,441	1,500

		L	X
124795	10.500	941	1,000
124790	12.700	1,191	1,250
124781	15.400	1,441	1,500

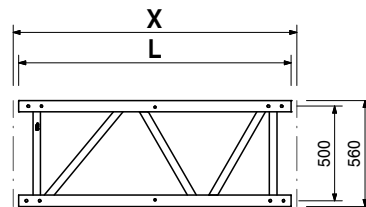
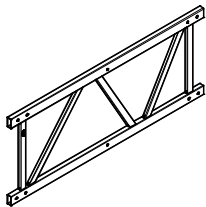

124806 5.990 **Connector ULS Flex**

Complete with

8 pcs 124771 collar pin \varnothing 12 x 44, galv.
8 pcs 018060 cotter pin 4/1, galv.

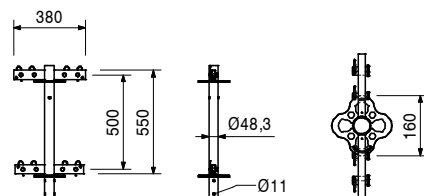

126009 1.630 **LGS Keder Connector URV**
For fixing Keder Tracks URK to scaffolding components with tube \varnothing 48.3 mm.

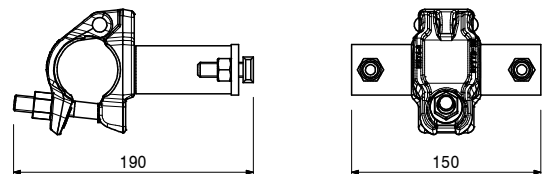
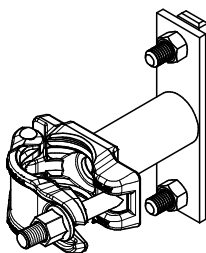

PERI UP Scaffolding Kit – Core components



Article no. Weight kg

Article no.	Weight kg	Description	L
127501	3.530	LGS Keder Tracks URK	1,500
127500	7.050	LGS Keder Track URK 150	3,000
126071	14.100	LGS Keder Track URK 300 LGS Keder Track URK 600	6,000

Track for drawing keder tarpaulins into scaffolding constructions.

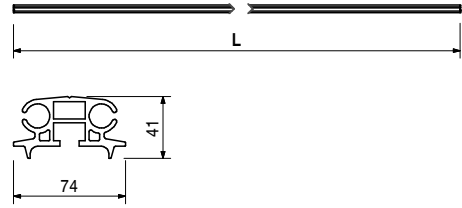
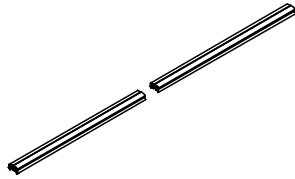

131097	1.700	Base plate for EWB
--------	-------	---------------------------

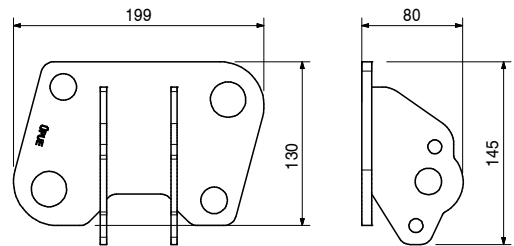
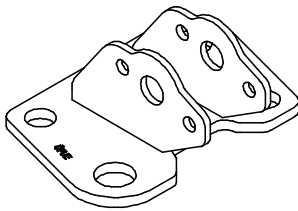

Accessories

710593	0.062	Bolt ISO 4014 M10 x 80-8.8, galv.
112786	0.015	Nut EN 1661 M10-8, galv.

131093	23.700	Multi Brace EWB
--------	--------	------------------------

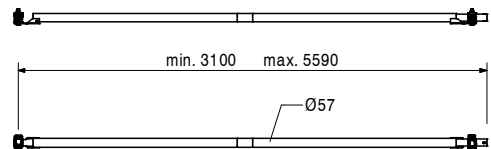
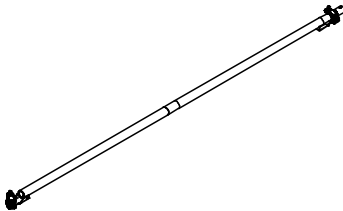

Accessories

131097	1.700	Base plate for EWB
--------	-------	---------------------------

131092	9.090	Scaffold support, coated
--------	-------	---------------------------------

Can be used as an additional inner tube for the EWB Multi Brace if required.

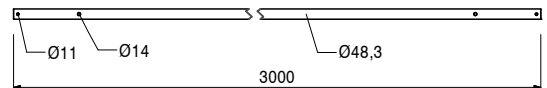
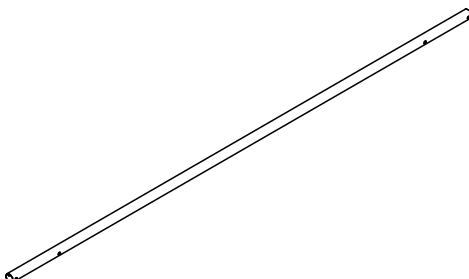

Article no. Weight kg

134175 0.065 **Poly Cover Couplings UPC-C**

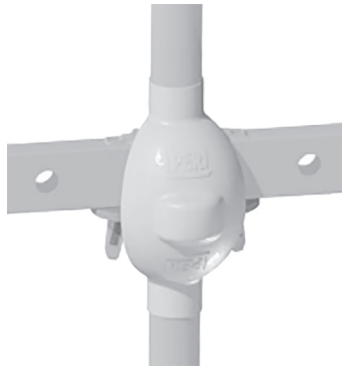

133907 0.015 **Poly Cover Tubes UPC-T**



134176 0.098 **Poly Cover Rosette UPC-R**



134177 0.186

Spindle Lining UES

The protective underlay for base spindles protects sensitive base decks from damage by the base spindle plate.

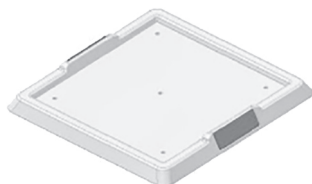

Article no. Weight kg

117466 10.600

Push-pull Prop RS 210, galv.

Extension length L = 1.30 – 2.10 m.
For aligning PERI formwork systems and prefabricated concrete elements.

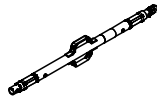

Note

See PERI Design Tables for permissible load.

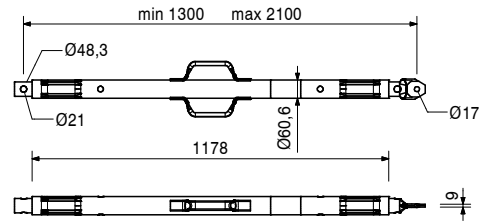

118238 12.100

Push-pull Prop RS 260, galv.

Extension length L = 2.30 – 2.60 m.
For aligning PERI formwork systems and prefabricated concrete elements.

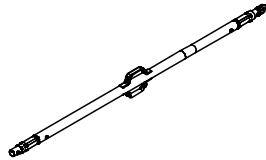

Note

See PERI Design Tables for permissible load.

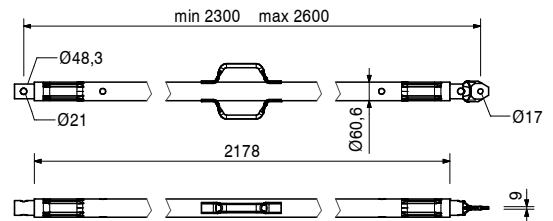

117467 15.500

Push-pull Prop RS 300, galv.

Extension length L = 1.90 – 3.00 m.
For aligning PERI formwork systems and precast concrete elements.

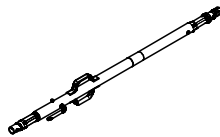

Note

See PERI Design Tables for permissible load.

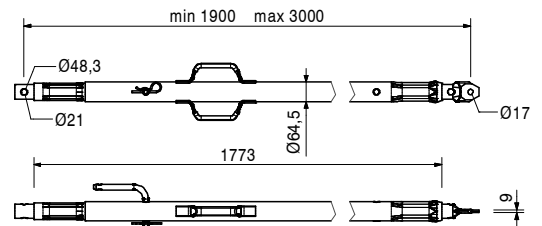

117468 23.000

Push-pull Prop RS 450, galv.

Extension length L = 2.80 – 4.50 m.
For aligning PERI formwork systems and prefabricated concrete elements.

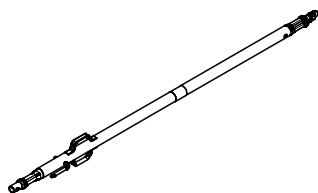

Note

See PERI Design Tables for permissible load.

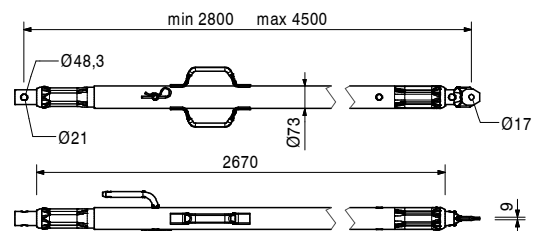

PERI UP Scaffolding Kit – Core components



Article no.	Weight kg
117469	39.900

Push-pull Prop RS 650, galv.
 Extension length L = 4.30 – 6.50 m.
 For aligning PERI formwork systems and precast concrete elements.

Note
 See PERI Design Tables for permissible load.

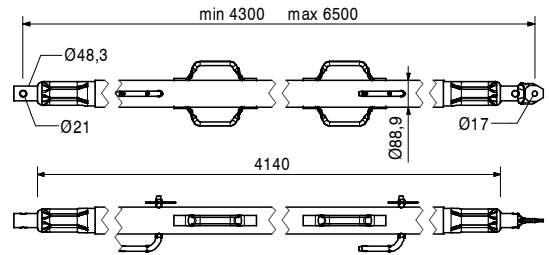
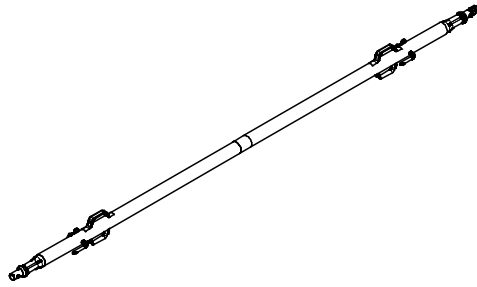

028990	115.000
--------	---------

Push-pull Prop RS 1000, galv.
 Extension length L = 6.40 – 10.00 m.
 For aligning PERI formwork systems.

Note
 See PERI Design Tables for permissible load.

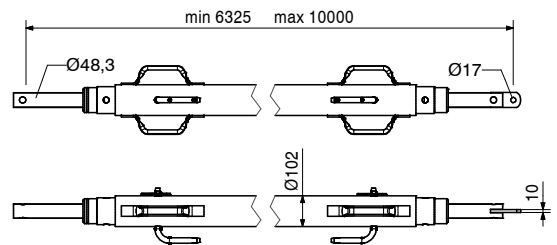
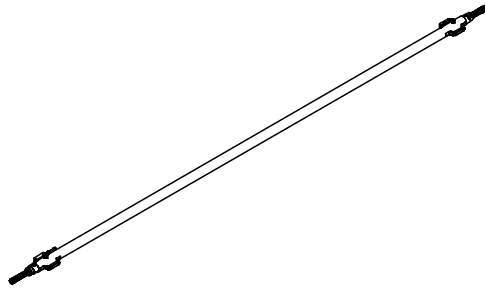

103800	271.000
--------	---------

Push-pull Prop RS 1400, galv.
 Extension length L = 6.40 – 14.00 m.
 For aligning PERI formwork systems.

Note
 See PERI Design Tables for permissible load.
 Chain attached/detached from the ground.

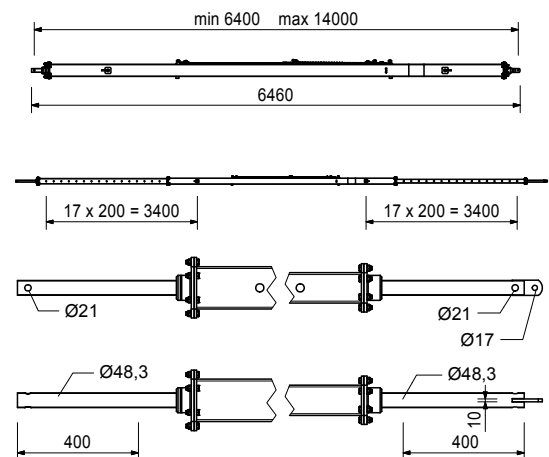
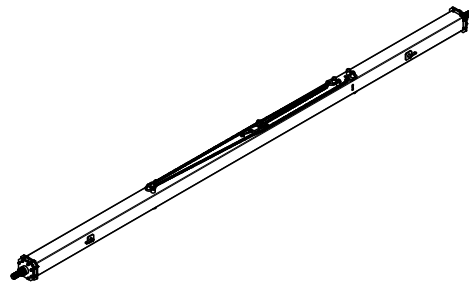

Article no. Weight kg

131723 1.440

Brace Connector HDR-2

For connecting push-pull props and kicker braces to components with \varnothing 48 mm.

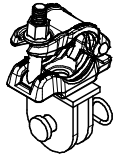

Complete with

1 pc. 027170 bolt \varnothing 16 x 42, galv.
1 pc. 018060 cotter pin 4/1, galv.

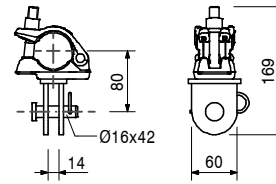

018060

0.014

Cotter pin 4/1, galv.



124777

0.210

Tie Bolt PERI

Tie Bolt PERI 14/20 x 130

132889

0.213

Tie Bolt PERI 14x150 AF21

For temporary fixing to reinforced concrete components.

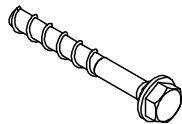

Note

Take the PERI Data Sheet into consideration!
Hole \varnothing 14 mm.

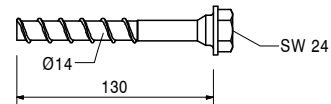

138009

0.060

Bolt ISO 4014 M10 x 70-10.9

As a tension-resistant connection of verticals for suspended scaffolds or formwork girders.

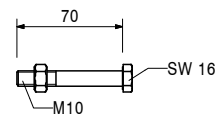
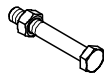

105400

0.330

Bolt \varnothing 20 x 140, galv.

For various connections.

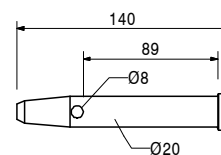
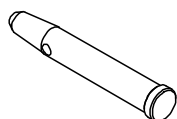

Accessories

018060

0.014

Cotter pin 4/1, galv.

The optimum system
for every project and
every requirement



Wall formwork



Column formwork

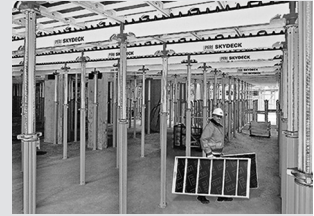

Slab formwork



Climbing systems



Bridge formwork



Tunnel formwork



Shoring



Working scaffolds construction



Working scaffolds facade



Working scaffolds industry

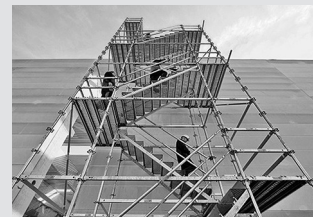

Means of access



Safety scaffolds



Safety systems



System-independent accessories



Services



PERI Ltd
Market Harborough Road
Clifton upon Dunsmore
Rugby
CV23 0AN
Telephone +44 (0)71788 86 16 00
Fax +44 (0)71788 86 16 10
info@peri.ltd.uk
www.peri.ltd.uk

